



## **Regulatory Fire & Safety Signage**

### **Victoria, British Columbia**

#### **Fire Routes**

Fire prevention in the 13 municipalities have different guidelines and rules for what they expect so there is no overall spec that they can provide

- Nothing in the code that is specific

#### **No Parking**

##### **Zoning Bylaw, Off-Street Parking Regulations**

<https://www.victoria.ca/assets/Departments/Planning~Development/Development~Services/Zoning/Bylaws/Zoning%20Bylaw%202018.pdf>

- Visitor parking spaces must be clearly identified for the sole use of visitors

##### **Streets and Traffic Bylaw, 09-079**

<https://www.victoria.ca/assets/City~Hall/Bylaws/bylaw-09-079.pdf>

- Private lanes must always exhibit, at its junction with a public street, a sign bearing the words "Private Lane" in letters that are at least 8cm high



## No Smoking

### **Capital Regional District Requirements:**

[https://www.crd.bc.ca/docs/default-source/crd-document-library/bylaws/publichealthcleanairidlingtanningtattoo/3962---capital-regional-district-clean-air-bylaw-no-1-2014-\(at-second-reading\).pdf?sfvrsn=12](https://www.crd.bc.ca/docs/default-source/crd-document-library/bylaws/publichealthcleanairidlingtanningtattoo/3962---capital-regional-district-clean-air-bylaw-no-1-2014-(at-second-reading).pdf?sfvrsn=12)

Signs must include

- Phrase “no smoking” or, the graphic symbol which is a minimum of 6cm in diameter
- May include the words “Capital Regional District Bylaw No. 3962 Maximum Penalty \$2,000.00”



## Towing

### **Towing Bylaw**

<https://www.victoria.ca/assets/City~Hall/Bylaws/bylaw-11-033.pdf>

For towing vehicles parked on a parking lot, signs must contain the following information:

- A warning to the effect that improperly or unlawfully parked vehicles will be towed at the owner's expense
- Name and telephone number of the towing company and the address at which the vehicle will be stored
- Towing and storage fees that will apply

## No Dumping

### **250.361.0215 Bylaw Services**

- No requirements for regulation because they are on private property



- Recommend that the signs be posted in places that are viewable upon entering the property or in specific locations where dumping occurs

## Underground Parking

### **250.361.0215 Bylaw Services - Building and Development**

- Follows whatever they have in the BC Building Code

### **BC Building Code - Proposed Changes Document**

[https://www2.gov.bc.ca/assets/gov/farming-natural-resources-and-industry/construction-industry/building-codes-and-standards/other/2018\\_bcfrc\\_02\\_emergency\\_lighting.pdf](https://www2.gov.bc.ca/assets/gov/farming-natural-resources-and-industry/construction-industry/building-codes-and-standards/other/2018_bcfrc_02_emergency_lighting.pdf)

- No requirement under the Building Code or the Fire Code to switch from “EXIT” signs (red on white background) to the green sign with the white pictogram of the running man

## Fire Safety Plan Box Provisions

### **Fire Safety and Prevention Bylaw**

[https://www.victoria.ca/assets/City~Hall/Bylaws/Fire%20Prevention\\_14-100.pdf](https://www.victoria.ca/assets/City~Hall/Bylaws/Fire%20Prevention_14-100.pdf)

- Must remain locked
- Red in colour and contains letters in white stating “Fire Safety Plan”
- Must be approved by the Fire Chief, or a Member authorized by them

### **2509203365**

- They are now allowing for various colours if the outside of the box indicates that it is for a fire safety plan (white and red are the most common)

## Accessibility Guidelines

### **Accessibility Guideline Handbook:**

[https://www2.gov.bc.ca/assets/gov/farming-natural-resources-and-industry/construction-industry/building-codes-and-standards/guides/2014\\_building\\_access\\_handbook.pdf](https://www2.gov.bc.ca/assets/gov/farming-natural-resources-and-industry/construction-industry/building-codes-and-standards/guides/2014_building_access_handbook.pdf)

General Sign Requirements:



- Glare-free surface
- Characters with a stroke width-to-height ratio of from 1:6 to 1:10
- Character width to height ratio of from 3:5 to 1:1
- Arabic numerals and sans-serif letters only
- Characters and symbols must contrast highly in colour with their background (85% to 95%)
  - Ex. blue or black backgrounds with white letters, yellow background with black letters
  - Exit signs are best with white letters on red background
- Contain the International Symbol of Accessibility for Persons with Disabilities, and any additional wording and symbols necessary

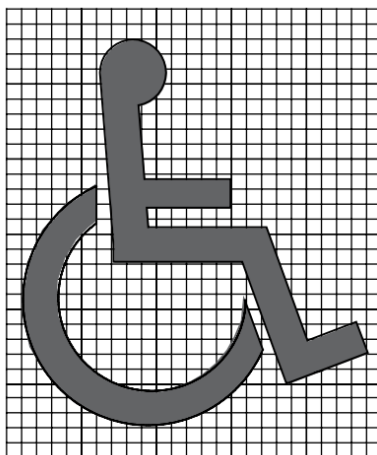

NOTE:  
BACKGROUND  
SQUARES ARE  
FOR PROPORTION  
REFERENCE  
ONLY

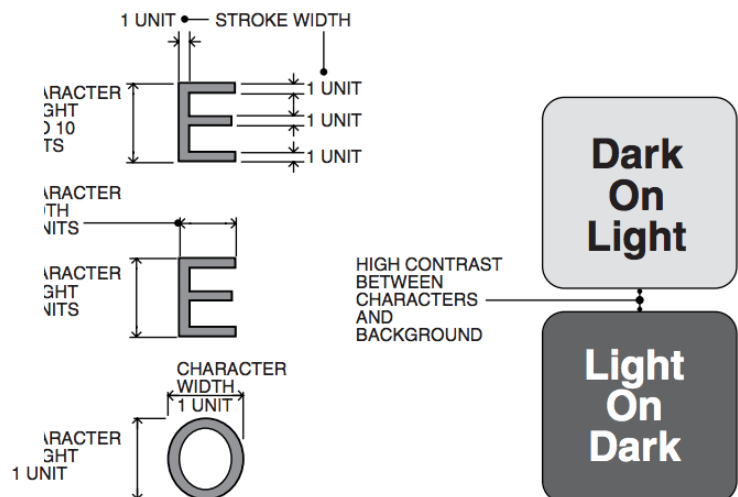

FIGURE 3.8.41. – Sign Characteristics

Examples of parking signs as well as commonly used directional signs:



# Safety Media

Fire & Life Safety Essentials

www.safetymedia.com

sales@safetymedia.com

1-800-420-9737

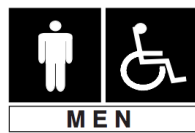
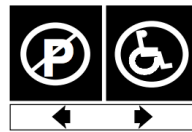

## Floor Numbering

- Arabic numerals shall be
- Not less than 60mm high
- Raised approximately 0.7mm above the surface
- Contrast in color with the surface they are applied to (white on black or black on white is recommended)

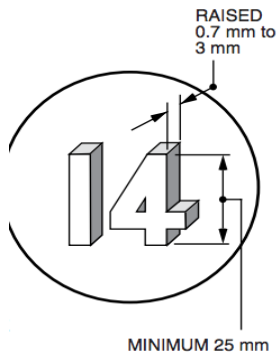



# *Safety Media*

Fire & Life Safety Essentials

www.safetymedia.com  
sales@safetymedia.com  
1-800-420-9737

## Other?

### ***Private streets and lanes***

[https://www.victoria.ca/assets/Departments/Legislative~Services/Streets%20and%20Traffic%20Bylaw%2009-079%20\(consolidated\).pdf](https://www.victoria.ca/assets/Departments/Legislative~Services/Streets%20and%20Traffic%20Bylaw%2009-079%20(consolidated).pdf)

- Must have a sign stating "Private Lane" in letters that are at least 8cm high, placed at the junction with a public street

***Disclaimer:*** The material and information contained on this document is for general information purposes only. Please contact your local authorities before making any business, legal or other decision.