



Regulatory Fire & Safety Signage

Kelowna, British Columbia

Fire Routes

Fire and Life Safety Bylaw

https://apps.kelowna.ca/CityPage/Docs/PDFs/Bylaws/Fire_and_Life_Safety_Bylaw_No.10760.pdf

- Size and colour is approved by the Fire Chief or designate
- Sign must read: "FIRE LANE - NO PARKING"
- If secured by a gate/bollard/chain/other structure
 - Size of no less than 60cm by 75cm
 - Reads: "EMERGENCY ACCESS ONLY" "NO PARKING OR OTHER OBSTRUCTIONS" "Fire and Life Safety Bylaw No. 10760"

No Parking

Bylaw Services, 2504968686

- According to the customer service representative, Kelowna's parking services does not enforce on private property



No Smoking

<https://apps.kelowna.ca/CityPage/Docs/PDFs/Bylaws/Clean%20Indoor%20Air%20and%20Smoking%20Regulation%20Bylaw%20No.%205980-86.pdf>

Sign must state:

- The phrase 'no smoking'
- A graphic symbol, minimum of 4 inches in diameter
- May include the words "Bylaw No. 5980-86" or "Bylaw No. 5080-86 Maximum Penalty \$500.00"

Designated Smoking Area sign must state:

- "Smoking permitted in this area only" or
- "Smoking permitted" or
- Words or graphic symbols of similar meaning

All signs:

- Consist of contrasting colours, or the lettering must contrast to the colour of the background

Workplace:

- Must post a sign stating the ratio of smoking to non-smoking seating in effect at the workplace (see below)





Towing

See information under [No Parking](#)

No Dumping

Illegal Dumping

<https://www.regionaldistrict.com/your-services/waste-reduction-office/illegal-dumping.aspx>
https://www.regionaldistrict.com/media/17211/consolidated_ticket_information_utilization_bylaw_435.pdf

- Waste management services falls under the Regional District of Central Okanagan
- Fines for illegal dumping can range from \$100 under the Solid Waste Management Bylaw, and up to \$2,000 under the Offences Act

Bylaw Services, 250-469-8686

- No answer

Underground Parking

Bylaw Services, 250-469-8686

- Did not know of any specific signage requirements other than what is prescribed by the building code
- Recommended looking into site plans/guidelines

Urban Design Guidelines

<https://apps.kelowna.ca/CityPage/Docs/PDFs/Bylaws/Official%20Community%20Plan%202030%20Bylaw%20No.%2010500/Chapter%2014%20-%20Urban%20Design%20DP%20Guidelines.pdf>

- No specific signage requirements stated for underground/below-grade/structured parking



Fire Safety Plan Box Provisions

Fire and Life Safety Bylaw

https://apps.kelowna.ca/CityPage/Docs/PDFs/Bylaws/Fire_and_Life_Safety_Bylaw_No.10760.pdf

- Information for lock boxes is given upon applying for permits
- Fire safety plan box must be approved by the Fire Chief (however it is not required)

2504698801

- Kelowna has no current requirements for having one/for what one needs to look like
- The fire safety plan itself must be easily accessible

Accessibility Guidelines

For outdoor signs:

https://www.kelowna.ca/sites/files/1/docs/related/guidelines_for_accessibility_in_outdoor_areas.pdf

- International symbols of accessibility are used to identify any accessible entrance or facility
- Must contrast with background colour and the surrounding surface
 - Black on white is preferred, other suggestions seen below in table
- Lettering:
 - Character width to height ratio should be between 3:5 and 1:1
 - Character stroke width to height ratio should be between 1:5 and 1:10
 - Preferably raised at least 1mm from background
 - Clear and legible fonts used with normal spacing
 - Smallest letter type should be not less than 15mm
- Tactile signs
 - Characters raised at least 1mm with gently rounded edges
- Braille signs
 - Grade 1 Braille should be used for signs of 10 words or less
 - Grade 2 Braille should be used for signs of more than 10 words



Figure 20 - International symbol of accessibility. The symbol contrast shall be light on dark, or dark on light.

Background Surface	Sign Background	Colour of Lettering
Light brick or light stone	Dark (black preferred)	White or Yellow
Whitewashed wall	Dark (black preferred)	White/Yellow
Red brick or dark stone	White	Black, dark green, or dark blue.
Green vegetation	White	Black, dark green, or dark blue.

BC Building Access Handbook

https://www2.gov.bc.ca/assets/gov/farming-natural-resources-and-industry/construction-industry/building-codes-and-standards/guides/2014_building_access_handbook.pdf

General Sign Requirements:

- Glare-free surface
- Characters with a stroke width-to-height ratio of from 1:6 to 1:10
- Character width to height ratio of from 3:5 to 1:1
- Arabic numerals and sans-serif letters only
- Characters and symbols must contrast highly in colour with their background (85% to 95%)
 - Ex. blue or black backgrounds with white letters, yellow background with black letters
 - Exit signs are best with white letters on red background

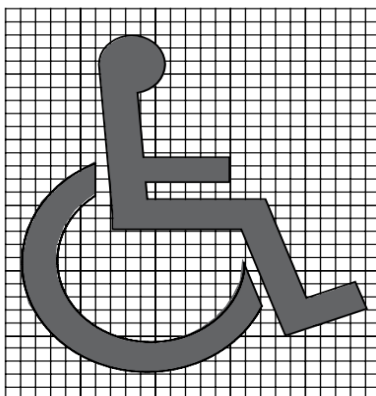

NOTE: BACKGROUND SQUARES ARE FOR PROPORTION REFERENCE ONLY

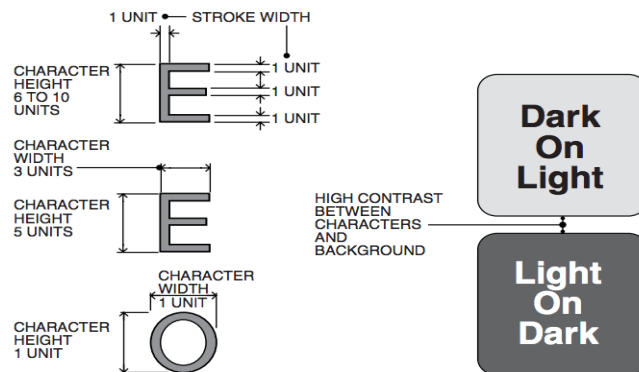
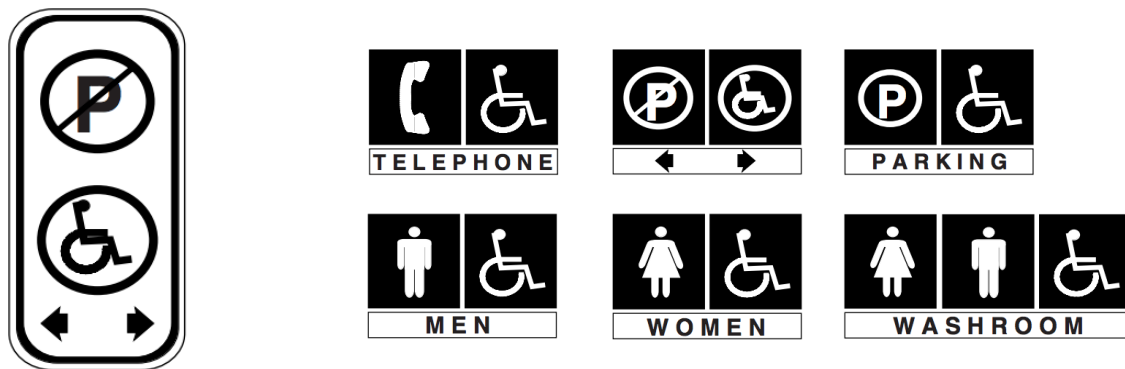

FIGURE 3.8.41. – Sign Characteristics

- Contain the International Symbol of Accessibility for Persons with Disabilities, and any additional wording and symbols necessary



Examples of parking signs as well as commonly used directional signs:



Floor Numbering

- Arabic numerals shall be
 - Not less than 60mm high
 - Raised approximately 0.7mm above the surface
 - Contrast in colour with the surface they are applied to (white on black or black on white is recommended)

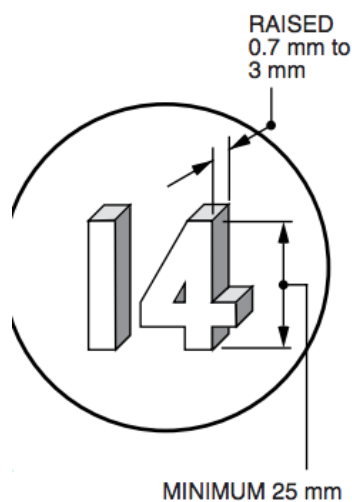



Other?

Fire Safety - Other building signs

https://apps.kelowna.ca/CityPage/Docs/PDFs/Bylaws/Fire_and_Life_Safety_Bylaw_No.10760.pdf

Owners of buildings that are equipped with a passenger elevator must have a sign stating:

- "IN CASE OF FIRE, USE EXIT STAIRWAY"
- "DO NOT USE ELEVATOR"
- Size must be at least 75mm by 130mm
- Sign is printed on permanent red and white, or white on red plastic laminate or equivalent material

Owners of buildings with three or more stories but place signs at stairwells to identify the floor level

- Numbers: minimum height is 150mm
- Wording: not less than 50mm by 150mm
- Placed on permanent red on white, or white on red plastic laminate or equivalent material

Disclaimer: *The material and information contained on this document is for general information purposes only. Please contact your local authorities before making any business, legal or other decision.*