

[click to enlarge](#)[click to enlarge](#)[click to enlarge](#)[Schematic](#) | [Chart](#) |  
[Abbreviations & Terms](#)[Find this Yarn](#)

This cropped cardigan has a cleverly shaped hood and striking leaf-like texture adorning the fronts.



### [PDF Pattern Instructions](#)

(If you can't open this PDF file you need Adobe Acrobat Reader. Get it [here](#).)

### Shown in size Small

#### SIZES

Directions are for women's size X-Small. Changes for sizes Small, Medium, Large, 1X and 2X are in parentheses.

#### FINISHED MEASUREMENTS

Bust (closed) – 34(38-42-46-50-54)''

Length – 14½(15-16-16½-17½-18)''

**Note:** This garment was designed with a slightly oversized fit. Please take this into consideration when selecting your size.

#### MATERIALS

5(6-7-8-9-9) Hanks **BERROCO CAMPUS** (100 grs), #2478 College Try  
 Straight knitting needles, sizes 10 (6.00 mm) and 10½ (6.50 mm) OR SIZE TO OBTAIN GAUGE  
 2 St markers  
 2 St holders

### GAUGE

12 sts = 4"; 16 rows = 4" in St st on size 10½ needles  
 TO SAVE TIME, TAKE TIME TO CHECK GAUGE

### BACK

With size 10 needles, cast on 62(70-78-82-90-98) sts.

**Ribbing: Row 1 (WS):** P2, \* k2, p2, rep from \* across.

**Row 2:** K2, \* p2, k2, rep from \* across. Rep these 2 rows until piece measures 3" from beg, end on RS. Change to size 10½ needles and knit 1 row on WS for Garter Ridge, dec 9(11-13-11-13-15) sts across – 53(59-65-71-77-83) sts. Work even in St st until piece measures 6(6-7-7-8-8)" from beg, end on WS.

**Shape Raglan Armholes:** Bind off 3(3-3-3-5-5) sts at beg of the next 2 rows – 47(53-59-65-67-73) sts. Work 2(2-0-0-0-0) rows even, end on WS.

**For Sizes Medium, Large, 1X and 2X ONLY: Dec Row 1 (RS):** K1, k3 tog, k to last 4 sts, sl 1, k2 tog, pssso, k1 – 55(61-63-69) sts. Rep this dec every RS row 1(3-4-6) times more, end on WS – 51(49-47-45) sts.

**For ALL Sizes: Dec Row 2 (RS):** K1, k2 tog, k to last 3 sts, SSK, k1 – 45(51-49-47-45-43) sts. Rep this dec every 4th row 2(0-0-0-0) times more, then every RS row 11(16-15-14-13-12) times, end on WS. Bind off remaining 19 sts for back neck.

### LEFT FRONT

With size 10 needles, cast on 43(47-51-55-59-63) sts.

**Establish Pat St: Row 1 (WS):** Sl 2 WYIF, k1, p1, k2, work Row 1 of Chart over 11 sts, k2, p1, k1, place marker, p2, (k2, p2) 5(6-7-8-9-10) times.

**Row 2:** K2, (p2, k2) 5(6-7-8-9-10) times, sl marker, p1, k1, p2, work Row 2 of Chart over 11 sts, p2, k1, p1, k2. Work even in pat as established until piece measures 3" from beg, end on RS. Change to size 10½ needles.

**Next Row (WS):** Work in pat as established to marker, sl marker, k to end for Garter Ridge, dec 2(3-4-5-6-7) sts across – 41(44-47-50-53-56) sts. Keeping 21 sts at front edge in pat as established and remaining sts in St st, work even until piece measures 6(6-7-7-8-8)" from beg, end on WS.

**Shape Raglan Armhole: Next Row (RS):** Bind off 3(3-3-3-5-5) sts, work to end – 38(41-44-47-48-51) sts. Work 3(3-1-1-1-1) rows even, end on WS.

**For Sizes Medium, Large, 1X and 2X ONLY: Dec Row 1 (RS):** K1, k3 tog, work to end – 42(45-46-49) sts. Rep this dec every RS row 0(2-3-5) times more, end on WS – 42(41-40-39) sts.

**For ALL Sizes: Dec Row 2 (RS):** K1, k2 tog, work to end – 37(40-41-40-39-38) sts. Rep this dec every 4th row 3(1-0-0-0-0) times more, then every RS row 4(9-11-10-9-8) times, end on WS – 30 sts. Armhole should measure 6(6½-6½-7-7-7½)".

**Shape Neck: Next Row (RS):** K1, k2 tog, k to marker, drop marker, sl last 21 sts onto holder. Continuing to work 4 more armhole decs, dec 1 st at neck edge every RS row 3 times. When all decs have been completed, fasten off last st.

### RIGHT FRONT

With size 10 needles, cast on 43(47-51-55-59-63) sts.

**Establish Pat St: Row 1 (WS):** P2, (k2, p2) 5(6-7-8-9-10) times, place marker, k1, p1, k2, work Row 1 of Chart over 11 sts, k2, p1, k1, p2.

**Row 2:** Sl 2 WYIB, p1, k1, p2, work Row 2 of Chart over 11 sts, p2, k1, p2, sl marker, k2, (p2, k2) 5(6-7-8-9-10) times. Complete to correspond to left front, reversing all shaping. Bind off for armhole on WS row. Work armhole decs at end of RS rows as sl 1, k2 tog, pssso, k1 instead of k1, k3 tog and as SSK, k1 instead of k1, k2 tog. For neck, end on WS row. On next row, work 21 sts and sl them to holder, drop marker, then complete same as left front.

### SLEEVES

With size 10 needles, cast on 46(50-54-58-62-66) sts. Work in ribbing same as back for 6", end on RS. Change to size 10½ needles and k the next row for Garter Ridge, dec 6(6-8-8-10-10) sts across – 40(44-46-50-52-56) sts. Work even in St st until sleeve measures 7" from beg, end on WS.

**Shape Raglan Cap:** Bind off 3(3-3-3-5-5) sts at beg of the next 2 rows – 34(38-40-44-42-46) sts. Work 2 rows even, end on WS.

**Dec Row (RS):** K1, k2 tog, k to last 3 sts, SSK, k1 – 32(36-38-42-40-44) sts. Rep this dec every 4th row 5(4-3-2-3-2) times more, then every RS row 5(8-10-13-11-14) times, end on WS. Bind off remaining 12 sts.

**FINISHING**

Sew raglan sleeve caps to raglan armholes.

**Hood:** With RS facing, sl 21 sts from right holder to size 10 needle, join yarn and pick up and k28 sts around entire neck edge to left holder, then work 21 sts from left holder in pat as established – 70 sts.

**Ribbing: Row 1 (WS):** Sl WYIF, k1, place marker, p1, \* k1, p1, rep from \* to last 3 sts, place marker, k1, p2.

**Row 2:** Sl 2 WYIB, p1, sl marker, k1, \* p1, k1, rep from \* to next marker, sl marker, p1, k2. Rep these 2 rows twice more, end on RS.

**Next Row (WS):** Work in pat as established, inc 7 sts as evenly spaced as possible between markers – 77 sts. Change to size 10½ needles. Keeping 3 sts at each edge in pat as established and remaining sts in St st, work even until piece measures 8" above last row of ribbing, end on WS.

**Shape Top: Short Rows: Row 1 (RS):** K49, sl 1, k1, pssso, turn leaving remaining sts on LH needle.

**Row 2 (WS):** Sl 1, p23, p2 tog, turn.

**Row 3 (RS):** Sl 1, k23, sl 1, k1, pssso, turn.

**Row 4 (WS):** Sl 1, p23, p2 tog, turn. Rep Rows 3 and 4 until 23 sts remain on needle, end on WS. Bind off in k1, p1 ribbing. Sew side and sleeve seams.

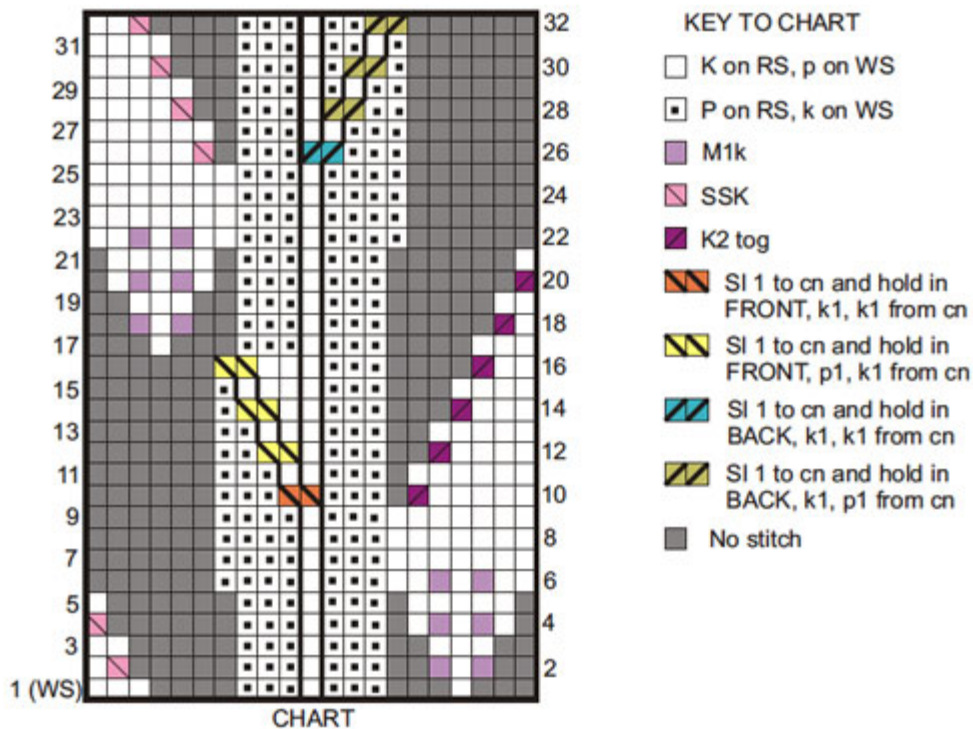

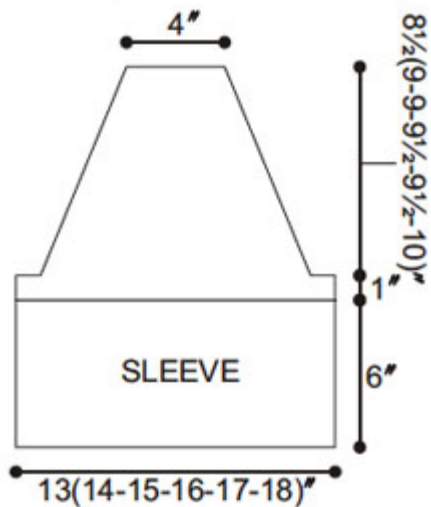
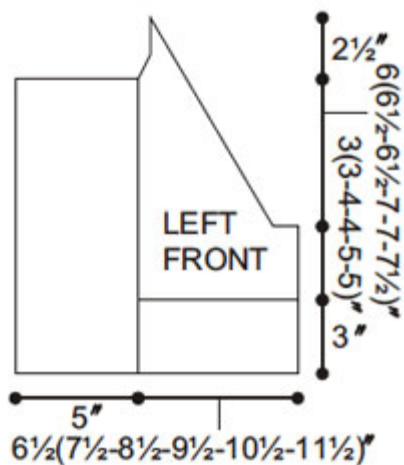
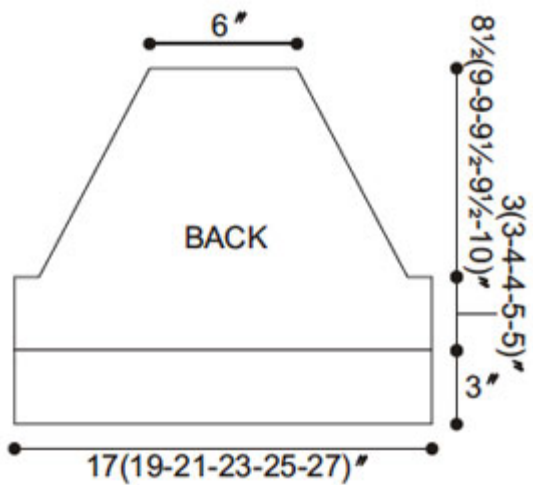

WEB EXCLUSIVE

[www.berroco.com](http://www.berroco.com)

[Home](#) | [Yarn Shops](#) | [Yarns](#) | [Free KnitBits®](#) | [New This Season](#) | [Free Patterns](#) | [Blog](#) | [Multimedia](#)  
[Pattern Corrections](#) | [Abbreviations & Terms](#) | [Links](#) | [Handeze® Glove](#) | [Scarf Central](#)  
[About Us](#) | [Privacy Statement](#) | [FAQs](#) | [Contact Us](#)

Berroco, Inc. 1 Tupperware Dr. Suite 4, N. Smithfield, RI 02896-6815 USA

