

# ellen cardigan

Designed by Amy Christoffers

Berroco Ellen Cardigan

version 4

Love Berroco patterns? Sign up for our [KnitBits® newsletter](#).

**skill level:** Intermediate  
Shown in size Small

## sizes

Directions are for women's size XS.  
Changes for sizes Small, Medium, Large  
and 1X are in parentheses  
To Fit Bust Size: 32(36-40-44-48)"

## finished measurements

Bust (closed) – 33(36½-41-46-49)"  
Length – 22½(22¾-23½-24½-25)"

Note: This garment was designed to fit  
with little or no ease. Please take this into  
consideration when selecting your size.

## materials

5(5-6-7-8) Hanks **BERROCO ULTRA ALPACA**  
(100 grs), #62173 Forest Mix (MC) and 1  
hank each #62178 Grapefruit Mix (CC1),  
#62168 Candy Floss Mix (CC2), #6287  
Denim Mix (CC3), #62189 Barley (CC4),  
#6299 Lichen Mix (CC5) and #6292 Tiger's  
Eye Mix (CC6)

29" Length circular knitting needles, sizes  
6 (4.00 mm) and 7 (4.50 mm) OR SIZE TO  
OBTAIN GAUGE

1 Set (4) each double pointed knitting  
needles (dpns), sizes 6 (4.00 mm) and 7  
(4.50 mm)

4 St markers

Waste yarn (to hold sleeve sts)

Nine ¾" buttons

## gauge

19 sts and 24 rows = 4" in St st

19 sts and 26 rows = 4" in St st over Chart 1

TO SAVE TIME, TAKE TIME TO CHECK  
GAUGE

Free Pattern



## Berroco Ultra® Alpaca



Find this yarn  
at your LYS

Our supercharged store locator goes above and beyond  
the ordinary. Innovatively linked to our inventory system,  
search for a yarn in your area and you'll pinpoint LYS's  
that have a proven history of ordering that product. A  
handy listing of all of the Berroco yarns the store carries  
and easy access to driving directions are also right at your  
finger tips. [Find all yarns now.](#)

 **BERROCO®**  
[www.berroco.com](http://www.berroco.com)

Don't forget to connect with us on social media!



**NOTE:** We recommend using yarns called for in our instructions. Every effort has been made to ensure that directions contained in this book are accurate and complete, however errors do occur. We cannot be responsible for variance of individual knitters, human or typographical errors.

All pattern PDFs are updated when corrections are made. In the event of finding an error, please make sure you've downloaded the most recent version.

## NOTES

This garment is worked in one piece from the neck down. After finishing the yoke, sts are held on waste yarn for sleeves while body is worked. Sleeves are then worked down in the round. There is some short row shaping on yoke. When working short rows, you will work part way across a row, then turn and work back in the opposite direction, leaving some sts unworked.

## STITCH GLOSSARY

### **RLI (Right lifted increase)**

Insert point of RH needle into the next st in the row below and sl this st up onto LH needle. Knit this st - 1 st inc'd.

### **LLI (Left lifted increase)**

Insert point of RH needle into the st just worked in the row below and sl this st up onto LH needle. Knit this st TBL - 1 st inc'd.

### **W&T (Wrap and turn)**

When knitting, bring yarn to the front, sl next st to RH needle, bring yarn to the back, turn; sl same st to RH needle, bring yarn across st and purl as directed (the slipped st is now a wrapped st).

When purling, bring yarn to the back, sl next st to RH needle, bring yarn to the front, turn; sl same st to RH needle, bring yarn across st and knit as directed (the slipped st is now a wrapped st)

## YOKE

With larger 29" long circular needle, using MC, loosely cast on 107 sts. DO NOT join. Purl 1 row on WS. Join CC1 and, working in St st, begin working Chart 1. After completing Row 3, there will be 134



sts on needles. After completing Row 17, there will be 161 sts on needles. Work Chart 2 for 2 rows, end on RS.

Note: When working short rows, each time you come to a wrapped st, lift wrap back over st and sl it onto LH needle, k (or p) this st together with its accompanying st. This helps prevent holes.

### **Establish Raglan Markers: Next Row (WS):**

P27(28-29-31-32) for right front, pm (place marker), p28(26-24-20-18) for right sleeve, pm, p51(53-55-59-61) for back, pm, p28(26-24-20-18) for left sleeve, pm, then p27(28-29-31-32) for left front - there are now 4 markers marking where raglan incs will occur.

**Short Rows: Row 1 (RS):** K to 1 st before first marker, LLI, k1, sm (slip marker), k1, RLI, k to 1 st before second marker, LLI, k1, sm, k1, RLI, k to 1 st before third marker, LLI, k1, sm, k1, RLI, k13(12-11-9-8), W&T.

**Row 2 (WS):** P15(14-13-11-10) to marker, sm, p across back sts, sm, p15(14-13-11-10), W&T.

**Row 3 (RS):** K to 1 st before marker, LLI, k1, sm, k1, RLI, k across back sts to 1 st before marker, LLI, k1, sm, k1, RLI, k across left sleeve to 1 st before

fourth marker, picking up the wrap and working it together with its stitch, LLI, k1, sm, k1, RLI, k3, W&T.

**Row 4 (WS):** P5, sm, p across right sleeve and back, sm, p across left sleeve, picking up the wrap and working it together with its stitch, sm, p5, W&T.

**Row 5 (RS):** Working the LLI, k1, k1, RLI increases at markers as established, work to wrapped st, picking up the wrap and working it together with its stitch, sm, k4, W&T – 8 sts inc'd.

**Row 6 (WS):** P to wrapped st, picking up the wrap and working it together with its stitch, p4, W&T. Rep Rows 5 and 6 twice more, end on WS.

**Next Row (RS):** Working the LLI, k1, sm, k1, RLI increases at markers as established, work to wrapped st, picking up the wrap and working it together with its stitch, k to end – 205 sts – 32(33-34-36-37) for each front, 39(37-35-31-29) for each sleeve and 63(65-67-71-73) for back.

**Next Row (WS):** P to wrapped st, picking up the wrap and working it together with its stitch, p to end.

Rep raglan increases (LLI, k1, sm, k1, RLI) at markers as established every 4th rnd 2(1-0-0-0) times, then every RS row 1(4-8-11-13) times – 229(245-269-293-309) sts – 35(38-42-47-50) sts for each front, 45(47-51-53-55) sts for each sleeve and 69(75-83-93-99) sts for back. Work 3 rows even, end on WS.

**Divide for Body and Sleeves: Next Row (RS):** K35(38-42-47-50) sts of left front, dm (drop marker), sl next 45(47-51-53-55) sts of left sleeve onto waste yarn, dm, using backwards loop method, cast on 4(5-6-7-8) sts for underarm, pm for side, cast on 3(4-5-6-7) for underarm, k69(75-83-93-99) sts of back, sl next 45(47-51-53-55) sts of right sleeve onto waste yarn, using backwards loop method, cast on 3(4-5-6-7) sts for underarm, pm for side, cast on 4(5-6-7-8) sts for underarm, k to end – 153(169-189-213-229) sts – 39(43-48-54-58) sts for each front and 75(83-93-105-113) sts for back.

## BODY

Beg with a p row, work even in St st for 2", end on WS.

**Dec Row (RS):** K to 3 sts before side marker, k2tog, k1, sm, k1, SSK, k to 3 sts before side marker, k2tog, k1, sm, k1, SSK, k to end – 4 sts dec'd. Rep Dec Row

every 12th row once more – 145(161-181-205-221) sts. Work 11 rows even, end on WS.

**Inc Row (RS):** \* K to 1 st before marker, M1R, k1, sm, k1, M1L, rep from \* once more, k to end – 4 sts inc'd. Rep Inc Row every 12th row once more – 153(169-189-213-229) sts. Work 11 rows even, end on WS. Join CC1 and work even, following chart 3 until 7 rows have been completed, end on RS. With MC, purl 1 row. Change to smaller 29" circular needle.

**Ribbing: Row 1 (RS):** K1, \* k1, p1, rep from \* to last 2 sts, end k2. Work even in ribbing as established for 2", end on WS. Bind off in ribbing.

## SLEEVES

With RS facing, sl 45(47-51-53-55) sleeve sts from waste yarn to larger dpn, dividing sts onto 3 needles. Join MC in center of sts cast on for underarm, pick up and k4(5-6-7-8) sts along cast-on edge, k45(47-51-53-55), then pick up and k3(4-5-6-7) sts along remainder of cast-on edge – 52(56-62-66-70) sts. Mark for beg of rnd and carry marker up. Work even in St st for 8(10-8-10-8) rnds.

**Note:** As you decrease, it may be necessary to readjust the arrangement of the sts on the dpn.

**Dec Rnd:** K1, k2tog, k to last 2 sts, SSK – 2 sts dec'd. Rep Dec Rnd every 10th(10th-8th-12th-10th) rnd 5(5-8-4-6) times more – 40(44-44-56-56) sts. Work even until sleeve measures 14½" from beg (or 3½" less than desired length). Join CC1 and work even, following Chart 3, until 7 rnds have been completed. Working with MC only, knit 1 rnd. Change to smaller dpns. Work even in k1, p1 ribbing for 2½". Bind off in ribbing.

## FINISHING

**Left Frontband:** With RS facing, using MC and smaller 29" circular needle, beg at neck edge, pick up and k94(98-100-102-104) sts along left front edge (approximately 3 sts over every 4 rows).

**Ribbing: Row 1 (WS):** \* K1, p1, rep from \* to last 2 sts, end k2. Work even in ribbing as established for 1", end on WS. Bind off in ribbing.

**Right Frontband:** Beg at lower edge, work as for left frontband for 3 rows, end on WS.

**Buttonhole Row (RS):** Work 4(6-6-4-5) sts, k2tog, yo, \* work 10(10-10-11-11) sts, k2tog, yo, rep from \* 6 times more, work to end. Complete as for left frontband.

**Neckband:** With RS facing, using MC and smaller 29" circular needle, beg at right front edge, pick up and k5 sts across right frontband, 105 sts evenly spaced around neck, then 5 sts across left frontband – 115 sts.

**Ribbing: Row 1 (WS):** P1, \* k1, p1, rep from \* across.

**Row 2 (RS):** K1, \* p1, k1, rep from \* across. Rep Row 1 once more, end on WS.

**Buttonhole Row (RS):** Work 2 sts, k2tog, yo, work to end. Work even in ribbing as established until neckband measures 1", end on WS. Bind off in ribbing. Sew on buttons. Weave in ends and block or steam as desired.

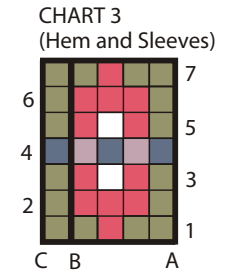
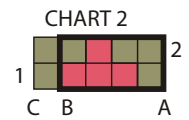
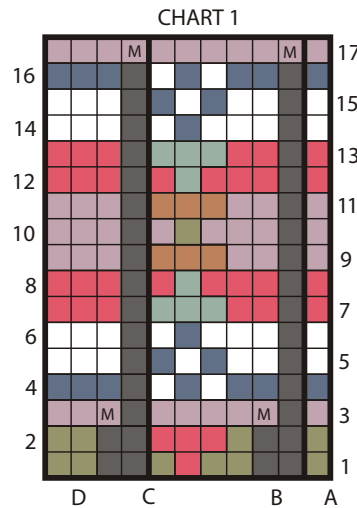

KEY TO CHARTS

- #62173 Forest Mix (MC)
- #62178 Grapefruit Mix (CC1)
- #62168 Candy Floss Mix (CC2)
- #6287 Denim Mix (CC3)
- #62189 Barley (CC4)
- #6299 Lichen (CC5)
- #6292 Tiger's Eye Mix (CC6)
- No Stitch
- M1

CHART NOTES

For Chart 1: On RS, beg at A, work to C, rep between B and C, end at D.  
On WS, beg at D, work to B, rep between C and B, end at A.

Work incs where indicated (the incs will replace No Stitch)

For Chart 2: On RS, beg at A, rep between A and B, end at C.  
On WS, beg at C, work to A, rep between B and A, end at A.

For Chart 3 for body: On RS, beg at A, rep between A and B, end at C.  
On WS, beg at C, work to A, rep between B and A, end at A.

For Sleeves, rep between A and B on ALL rnds (do not work from B to C).

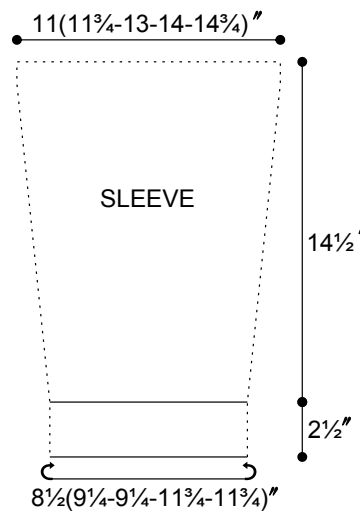
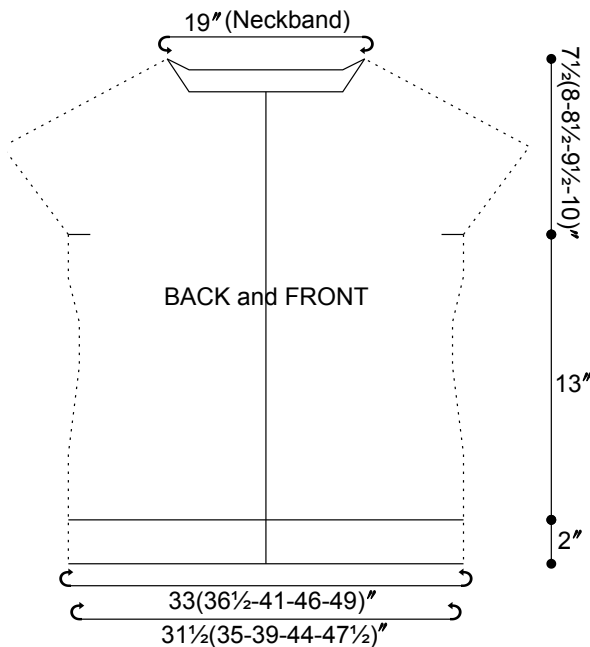

## ABBREVIATIONS & TERMS

### Knit

---

**beg:** beginning

**CC:** contrasting color

**cdd (centered double decrease):** Slip 2 together, knit 1, pass the 2 slipped stitches over.

**cn:** cable needle

**cont:** continue

**dec:** decrease

**dpn:** double pointed needles

**est:** established

**inc:** increase

**K:** knit

**k tbl:** knit through the back loop(s)

**k2tog:** Knit 2 stitches together

**k3tog:** Knit 3 stitches together

**LH:** left hand

**MC:** main color

**M1:** Pick up horizontal strand between stitch just worked and next stitch from front to back, place on left hand needle, knit this stitch through the back (1 stitch increased).

**M1L:** Work as for M1.

**M1p:** Pick up horizontal strand between stitch just worked and next stitch from front to back, place on left hand needle, purl this stitch through the back (1 stitch increased).

**M1pL:** Work as for M1p.

**M1pR:** Pick up horizontal strand between stitch just worked and next stitch from back to front, place on left hand needle, purl this stitch through the front (1 stitch increased).

**M1R:** Pick up horizontal strand between stitch just worked and next stitch from back to front, place on left hand needle, knit this stitch through the front (1 stitch increased).

**p:** purl

**p tbl:** purl through the back loop(s)

**pat(s):** pattern(s)

**pm:** place marker

**pssso:** pass slip stitch over knit stitch

**p2tog:** purl 2 stitches together

**p2sso:** pass 2 slip stitches over knit stitch

**p3tog:** purl 3 stitches together

**rem:** remaining

**rep:** repeat

**RH:** right hand

**rnd(s):** round(s)

**RS:** right side

**sl:** slip

**sm:** slip marker

**SSK:** Slip 2 stitches knitwise, insert point of left hand needle through fronts of these 2 stitches and knit 2 together.

**SSP:** Slip 2 stitches knitwise, transfer these 2 stitches back to left hand needle, purl 2 together through the back loops.

**st(s):** stitch(es)

**TBL:** through back loop(s)

**tog:** together

**WS:** wrong side

**wyib:** with yarn in back

**wyif:** with yarn in front

**yo:** yarn over

**end on WS:** end having just completed a Wrong Side row.

**end on RS:** end having just completed a Right Side row

**STOCKINETTE ST (St st):** Knit 1 row, purl 1 row alternately when working on straight needles. The knit side is the right side of work. Knit EVERY round when working in the round on a circular needle.

**Reverse St st (Rev St st):** Purl 1 row, knit 1 row alternately when working on straight needles. The purl side is the right side of the work. Purl EVERY round when working in the round on a circular needle.

**GARTER ST:** Knit EVERY row when working on straight needles. Knit 1 round, purl 1 round when working on a circular needle.

### Crochet

---

**ch:** chain

**dc:** double crochet

**hdc:** half double crochet

**sc:** single crochet

**sl st:** slip stitch

**sp:** space

**tr:** treble