

Ava

Designed by the Berroco Design Team



skill level: Intermediate
One size

finished measurements

Bust (closed)—70"
Length—30"

yarn

BERROCO ULTRA WOOL (100 grs):
9 balls #33147 Stonewashed

needles and notions

29" circular needles, sizes 6 (4.00 mm)
and 7 (4.00 mm) *or size to obtain
gauge*
Crochet hook, size 3.00 mm (E)
2 stitch markers

gauge

20 stitches and 27 rows = 4" in St st
on larger needle
*To save time and ensure accurate fit,
take time to check gauge*

[Berroco Ultra® Wool](#)

[Find this Yarn](#) 

BERROCO®



www.berroco.com

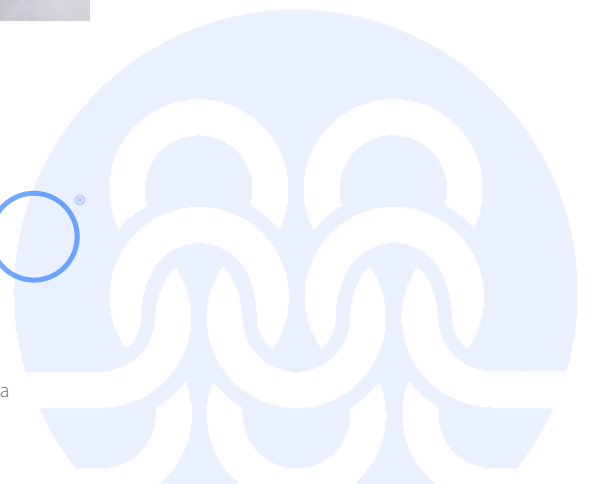

NOTE: We recommend using yarns called for in our instructions. Every effort has been made to ensure that directions contained in this book are accurate and complete, however errors do occur. We cannot be responsible for variance of individual knitters, human or typographical errors.

All pattern PDFs are updated when corrections are made. In the event of finding an error, please make sure you've downloaded the most recent version.

BACK

With smaller needle, cast on 188 sts. Do not join.

Ribbing: Row 1 (RS): K1, p1, k1, pm, * p2, k5, rep from * to last 3 sts, pm, k1, p1, k1.

Row 2: P1, k1, p1, sm, * p5, k2, rep from * to last marker, p1, k1, p1.

Work even in ribbing as established until piece measures 2" from beginning, end on WS. Change to larger needle.

Dec Row (RS): K1, p1, k1, sm, k1, * k2tog, k34, rep from * 4 times more, k1, sm, k1, p1, k1—183 sts.

Next Row (WS): P1, k1, p1, sm, purl to last marker, sm, p1, k1, p1.

Keeping 3 sts at each edge in ribbing as established and remaining sts in St st, work even until piece measures 9" from beginning, end on WS. Mark beg and end of last row for end of side slits. At this point, remove markers, discontinue ribbing at each side and work all sts in St st. Work even in St st until piece measures 30" from beginning, end on WS. Bind off.

LEFT FRONT

With smaller needle, cast on 90 sts. Do not join.

Ribbing: Row 1 (RS): K1, p1, k1, pm, * p2, k5, rep from * to last 3 sts, pm, k1, p1, k1.

Row 2: P1, k1, p1, sm, * p5, k2, rep from * to last marker, sm, p1, k1, p1.

Work even in ribbing as established until piece measures 2" from beginning, end on WS. Change to larger needle.

Dec Row (RS): K1, p1, k1, sm, [k2tog, k39] twice, k2tog, sm, k1, p1, k1—87 sts.

Next Row (WS): P1, k1, p1, sm, purl to last marker, sm, p1, k1, p1.

Keeping 3 sts at each edge in ribbing as established and remaining sts in St st, work even until piece measures 9" from beginning, end on WS. Mark end of last row for end of side slit.



Next Row (RS): K3, remove marker, knit to last marker, sm, k1, p1, k1 (these 3 sts are the front band). Keeping 3 sts at front edge in ribbing as established and remaining sts in St st, work even until piece measures 30" from beginning, end on WS. Bind off.

RIGHT FRONT

Work as for back until piece measures 9" from beginning, end on WS—87 sts. Mark beginning of last row for end of side slit.

Next Row (RS): K1, p1, k1, (these 3 sts are the front band), sm, knit to end, removing second marker. Keeping 3 sts at front edge in ribbing as established and remaining sts in St st, work even until piece measures 30" from beginning, end on WS. Bind off.

SLEEVES

With smaller needle, cast on 62 sts. Do not join.

Ribbing: Row 1 (RS): K2, * p2, k5, rep from * to last 4 sts, end p2, k2.

Row 2: P2, k2, * p5, k2, rep from * to last 2 sts, end p2. Rep these 2 rows until piece measures 2" from



beginning, end on WS. Change to larger needle.

Dec Row (RS): K2, k2tog, knit to last 3 sts, SSK, k2—60 sts. Beginning with a purl row, work even in St st until sleeve measures 3" from beginning, end on WS.

Inc Row (RS): K1, M1R, knit to last st, M1L, k1—2 sts inc'd. Rep Inc Row every RS row 10 times more, then every 4th row 7 times—96 sts. Work even until sleeve measures 11" from beginning, end on WS. Bind off.

FINISHING

Sew shoulder seams, leaving 3" at center of back open for back neck. Measure down 9½" from shoulder seams on fronts and back and mark for armholes. Sew on sleeves between armhole markers. Sew side and sleeve seams, leaving 9" below side slit markers on back and fronts open.

Neck Edging: With RS facing, using crochet hook, beginning at left front edge, work from left to right in Reverse sc around entire neck edge.

Weave in all ends and block as desired.



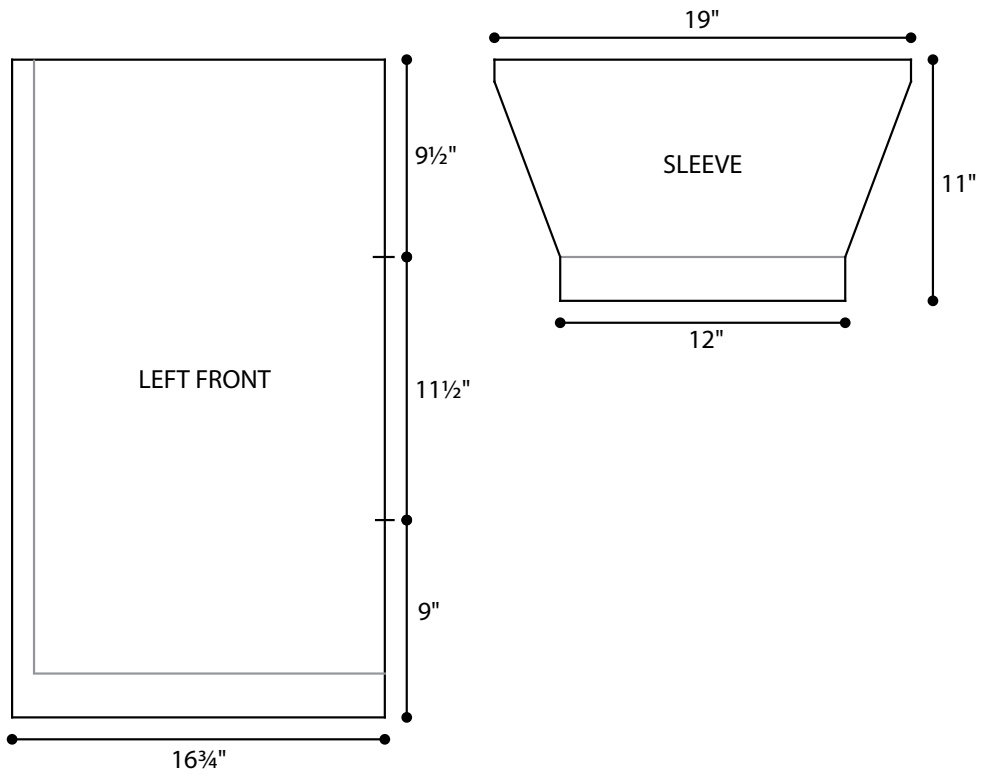
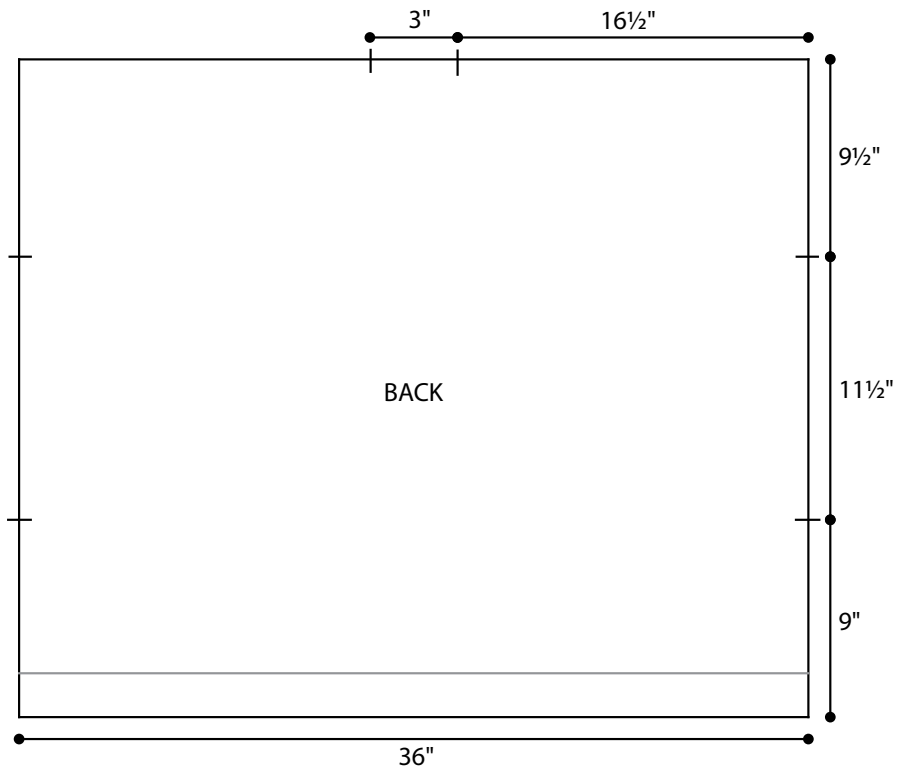

STANDARD ABBREVIATIONS & TERMS

beg: beginning
CC: contrasting color
CDD: Centered Double Decrease—Slip 2 together (as if to k2tog), knit 1, pass the 2 slipped stitches over
cn: cable needle
dec: decrease
dpn(s): double pointed needle(s)
end on WS: end having just completed a Wrong Side row.
end on RS: end having just completed a Right Side row
Garner St: Knit EVERY row when working back and forth in rows. Knit 1 round, purl 1 round when working in the round.
inc: increase
k: knit
k tbl: knit through the back loop(s)
k2tog: knit 2 stitches together
k3tog: knit 3 stitches together
kfb: knit in the front and back of the next st
LH: left hand
LLI: Left Lifted Increase—Insert LH needle into the purl bump one row below the st just worked on the RH needle and knit into this st (1 st inc'd)
M1: Make 1—Pick up horizontal strand between stitch just worked and next stitch from front to back, place on left hand needle, knit this stitch through the back (1 stitch increased).
M1L: Make 1 Left—Work as for M1.
M1p: Make 1 purl—Pick up horizontal strand between stitch just worked and next stitch from front to back, place on left hand needle, purl this stitch through the back (1 stitch increased).
M1pL: Make 1 purl Left—Work as for M1p.
M1pR: Make 1 purl Right—Pick up horizontal strand between stitch just worked and next stitch from back to front, place on left hand needle, purl this stitch through the front (1 stitch increased).
M1R: Make 1 Right—Pick up horizontal strand between stitch just worked and next stitch from back to front, place on left hand needle, knit this stitch through the front (1 stitch increased).
MC: main color
p: purl
p tbl: purl through the back loop(s)
p2tog: purl 2 stitches together

p3tog: purl 3 stitches together
pat(s): pattern(s)
pm: place marker
pssso: pass slipped stitch over knit stitch
rep: repeat
Rev St st: Reverse Stockinette Stitch—Purl 1 row, knit 1 row alternately when working back and forth in rows. The purl side is the right side of the work. Purl EVERY round when working in the round.
RH: right hand
RLI: Right Lifted Increase—Insert RH needle into the purl bump of the next st on the LH needle and knit into this st (1 st inc'd)
rnd(s): round(s)
RS: right side
sl: slip
sm: slip marker
SSK: Slip 2 stitches knitwise, insert point of left hand needle through fronts of these 2 stitches and knit 2 together.
SSP: Slip 2 stitches knitwise, transfer these 2 stitches back to left hand needle, purl 2 together through the back loops.
SSSK: Slip 3 stitches knitwise, insert point of left hand needle through fronts of these 3 stitches and knit 3 together.
st(s): stitch(es)
St st: Stockinette Stitch—Knit 1 row, purl 1 row alternately when working back and forth in rows. The knit side is the right side of work. Knit EVERY round when working in the round.
tbl: through back loop(s)
w&t: wrap and turn, a method of concealing a hole created in short row shaping. *On RS rows:* With yarn held in front, slip next stitch purlwise, then bring yarn between needles to the back. Slip that same stitch back to the left needle. Turn your work. *On WS Rows:* With yarn held in back, slip next stitch purlwise, then bring yarn between needles to the front. Slip that same stitch back to the left needle. Turn your work. Unless otherwise indicated, each time you come to a wrapped stitch when working subsequent rows, slip the wrap back over stitch and onto needle, then work the wrap together with its accompanying stitch.
WS: wrong side
wyib: with yarn in back
wyif: with yarn in front
yo: yarn over

Love Berroco patterns?
 Sign up for our **KnitBits®** newsletter.

