

Cornish

Designed by the Berroco Design Team / Skill level: Intermediate



FINISHED MEASUREMENTS

Bust (closed): (32, 36, 40) [44, 48, 52, 56] {60, 64, 68}" / (81.5, 91.5, 101.5) [112, 122, 132, 142] {152.5, 162.5, 172.5} cm
Length: (16½, 16½, 17) [18, 18½, 19½, 20] {20, 20½, 21}" / (42, 42, 43) [45.5, 47, 49.5, 51] {51, 52, 53.5} cm

YARN

BERROCO ZINNIA (50 grs): (7, 8, 9) [10, 11, 13, 14] {15, 16, 18} balls #7146 South Sea

NEEDLES and NOTIONS

Knitting needles, size 8 / 5 mm
or size to obtain gauge
32" circular needle, size 5 / 3.75 mm

GAUGE

20 sts and 26 rows = 4" in St st on larger needles

To save time and ensure accurate measurements, take time to check gauge.

Berroco Zinnia™

Find this Yarn 



BERROCO®



www.berroco.com

We recommend using yarns called for in our instructions. Every effort has been made to ensure that directions contained in this book are accurate and complete, however errors do occur. We cannot be responsible for variance of individual knitters, human or typographical errors.

All pattern PDFs are updated when corrections are made. In the event of finding an error, please make sure you've downloaded the most recent version.

BACK

With smaller needle, cast on (90, 102, 110) [122, 130, 142, 150] {162, 170, 182} sts.

Set Up Rib: Row 1 (WS): P2, * k2, p2, rep from * across.

Row 2 (RS): K2, * p2, k2, rep from * across.

Rep these 2 rows until piece measures 1½" / 4 cm from beginning, end on WS, dec (0, 1, 0) [1, 0, 1] {0, 1, 0} st at each end of last row—(90, 100, 110) [120, 130, 140, 150] {160, 170, 180} sts.

Change to larger needles and work in St st until piece measures (2½, 2½, 2½) [2½, 2½, 3, 3] {3, 3, 3}" / (6.5, 6.5, 6.5) [6.5, 6.5, 7.5, 7.5] {7.5, 7.5, 7.5} cm from beginning, end on WS.

Dec Row (RS): K1, k2tog, knit to last 3 sts, SSK, k1—2 sts dec'd.

Rep Dec Row every 8th row 4 times more—(80, 90, 100) [110, 120, 130] {140, 150, 160} sts. Work even until piece measures (9, 9, 9) [9½, 9½, 10, 10] {10, 10, 10}" / (23, 23, 23) [24, 24, 25.5, 25.5] {25.5, 25.5, 25.5} cm from beginning, end on WS.

Shape Armholes: Bind off (5, 6, 8) [9, 11, 13, 15] {16, 18, 20} sts at beginning of the next 2 rows—(70, 78, 84) [92, 98, 104, 110] {118, 124, 130} sts.

Dec Row (RS): K1, k2tog, knit to last 3 sts, SSK, k1—2 sts dec'd.

Rep Dec Row every RS row (4, 5, 7) [8, 10, 12, 14] {15, 17, 19} times more—(60, 66, 68) [74, 76, 78, 80] {86, 88, 90} sts. Work even until armholes measure (7, 7, 7½) [8, 8½, 9, 9½] {9½, 10, 10½}" / (18, 18, 19) [20.5, 21.5, 23, 24] {24, 25.5, 26.5} cm, end on WS.

Shape Shoulders: Bind off (5, 7, 7) [9, 9, 10, 10] {12, 12, 13} sts at beginning of the next 2 rows, then (5, 6, 7) [8, 9, 9, 10] {11, 12, 12} sts at beginning of the next 2 rows. Bind off remaining 40 sts for back neck.

LEFT FRONT

With smaller needle, cast on (38, 42, 50) [54, 58, 62, 70] {74, 78, 82} sts. Work in ribbing as for back for 1½" / 4 cm, end on WS, dec (0, 0, 1) [1, 0, 0, 1] {1, 0, 0} st each end of last row—(38, 42, 48) [52, 58, 62, 68] {72, 78, 82} sts.





Change to larger needles and work in St st until piece measures (2½, 2½, 2½) [2½, 2½, 3, 3] {3, 3, 3}" / (6.5, 6.5, 6.5) [6.5, 6.5, 7.5, 7.5] {7.5, 7.5, 7.5} cm from beginning, end on WS.

Dec Row (RS): K1, k2tog, knit to end—1 st dec'd. Rep Dec Row every 8th row 4 times more—(33, 37, 43) [47, 53, 57, 63] {67, 73, 77} sts. Work even until piece measures (9, 9, 9) [9½, 9½, 10, 10] {10, 10, 10}" / (23, 23, 23) [24, 24, 25.5, 25.5] {25.5, 25.5, 25.5} cm from beginning, end on WS.

Shape Armhole and Neck: Bind off (5, 6, 8) [9, 11, 13, 15] {16, 18, 20} sts at beginning of the next row, knit to end—(28, 31, 35) [38, 42, 44, 48] {51, 55, 57} sts. Purl 1 WS row.

Note: Please read through this next section before starting to knit. Decreases at armhole and neck are worked at different intervals and you will need to keep track of each edge separately.

Dec Row (RS): K1, k2tog (armhole dec), knit to last 3 sts, SSK (neck dec), k1 – 2 sts dec'd.

Working decs in this manner, dec 1 st at armhole edge every RS row (4, 5, 7) [8, 10, 12, 14] {15, 17, 19} times more. AT THE SAME TIME, dec 1 st at neck edge every (4th, 4th, 4th) [6th, 6th, 6th, 6th] {6th, 6th, 6th} row (9, 10, 10) [2, 2, 5, 5] {7, 7, 10} times, then every (2nd, 2nd, 2nd) [4th, 4th, 4th, 4th] {4th, 4th, 4th} row (3, 1, 2) [9, 10, 6, 7] {4, 5, 1} times.

When all armhole and neck decs have been completed, work even on (10, 13, 14) [17, 18, 19, 20] {23, 24, 25} sts until armhole measures (7, 7, 7½) [8, 8½, 9, 9½] {9½, 10, 10½}" / (18, 18, 19) [20.5, 21.5, 23, 24] {24, 25.5, 26.5} cm, end on WS. Bind off (5, 7, 7) [9, 9, 10, 10] {12, 12, 13} sts at beginning of next RS row, then bind off remaining (5, 6, 7) [8, 9, 9, 10] {11, 12, 12} sts on the next RS row.

RIGHT FRONT

With smaller needle, cast on (38, 42, 50) [54, 58, 62, 70] {74, 78, 82} sts. Work in ribbing as for back for 1½" / 4 cm, end on WS, dec (0, 0, 1) [1, 0, 0, 1] {1, 0, 0} st each end of last row—(38, 42, 48) [52, 58, 62, 68] {72, 78, 82} sts.

Change to larger needles and work in St st until piece measures (2½, 2½, 2½) [2½, 2½, 3, 3] {3, 3, 3}" / (6.5, 6.5, 6.5) [6.5, 6.5, 7.5, 7.5] {7.5, 7.5, 7.5} cm from beginning, end on WS.

Dec Row (RS): Knit to the last 3 sts, SSK, k1—1 st dec'd. Rep Dec Row every 8th row 4 times more—(33, 37, 43) [47, 53, 57, 63] {67, 73, 77} sts. Work even until piece measures (9, 9, 9) [9½, 9½, 10, 10] {10, 10, 10}" / (23, 23, 23) [24, 24, 25.5, 25.5] {25.5, 25.5, 25.5} cm from beginning, end on RS.

Shape Armhole and Neck: Bind off (5, 6, 8) [9, 11, 13, 15] {16, 18, 20} sts at beginning of the next row, purl to end—(28, 31, 35) [38, 42, 44, 48] {51, 55, 57} sts.

Note: Please read through this next section before starting to knit. Decreases at armhole and neck are worked at different intervals and you will need to keep track of each edge separately.

Dec Row (RS): K1, k2tog (neck dec), knit to last 3 sts, SSK (armhole dec), k1—2 sts dec'd.

Working decs in this manner, dec 1 st at armhole edge every RS row (4, 5, 7) [8, 10, 12, 14] {15, 17, 19} times more. AT THE SAME TIME, dec 1 st at neck edge every (4th, 4th, 4th) [6th, 6th, 6th, 6th] {6th, 6th, 6th} row (9, 10, 10) [2, 2, 5, 5] {7, 7, 10} times, then every (2nd, 2nd, 2nd) [4th, 4th, 4th, 4th] {4th, 4th, 4th} row (3, 1, 2) [9, 10, 6, 7] {4, 5, 1} times.

When all armhole and neck decs have been completed, work even on (10, 13, 14) [17, 18, 19, 20] {23, 24, 25} sts until armhole measures (7, 7, 7½) [8, 8½, 9, 9½] {9½, 10, 10½}" / (18, 18, 19) [20.5, 21.5, 23, 24] {24, 25.5, 26.5} cm, end on RS. Bind off (5, 7, 7) [9, 9, 10, 10] {12, 12, 13} sts at beginning of next WS row, then bind off remaining (5, 6, 7) [8, 9, 9, 10] {11, 12, 12} sts on the next WS row.

SLEEVES

With smaller needles, cast on (42, 42, 46) [46, 50, 50, 54] {54, 58, 58} sts. Work in ribbing as for back for 1½" / 4 cm, end on WS. Change to larger needles and work in St st for 2 rows, end on WS.

Inc Row (RS): K1, M1R, knit to last st, M1L, k1—2 sts inc'd. Rep Inc Row every RS row (0, 0, 0) [5, 8, 11, 14] {18, 18, 20} times more, then every 4th row (8, 9, 9) [7, 5, 4, 2] {0, 0, 0} times—(60, 62, 66) [72, 78, 82, 88] [92, 96, 100] sts. Work even until sleeve measures 9½" / 24 cm from beginning, end on WS.

Shape Cap: Bind off (5, 6, 8) [9, 11, 13] {15, 16, 18} sts at beginning of the next 2 rows—(50, 50, 50) [54, 56, 56, 58] {60, 60, 60} sts.

Dec Row (RS): K1, k2tog, knit to last 3 sts, SSK, k1—2 sts dec'd.

Rep Dec Row every RS row (13, 13, 9) [11, 9, 7, 7] {7, 6, 2} times more, then every 4th row (2, 2, 5) [4, 6, 8, 8] {8, 9, 12} times, end on WS. Bind off remaining (18, 18, 20) [22, 24, 24, 26] {28, 28, 30} sts.

FINISHING

Sew shoulder seams.

Collar: With RS facing, using circular needle, begin at lower right front edge, pick up and knit approximately (82, 82, 85) [90, 92, 97, 100] {100, 102, 105} sts along right front and neck edge (3 sts for every 4 rows), 40 sts across back neck edge (1 st in each bound off st), then approximately (82, 82, 85) [90, 92, 97, 100] {100, 102, 105} sts along left front neck and front edge (3 sts for every 4 rows. Exact stitch count is not crucial. Beginning with a knit row, work even in Reverse St st for 6" / 15 cm, end on WS. Bind off.

Sew in sleeves. Sew side and sleeve seams. Weave in all ends and block as desired.

CORNISH SCHEMATIC

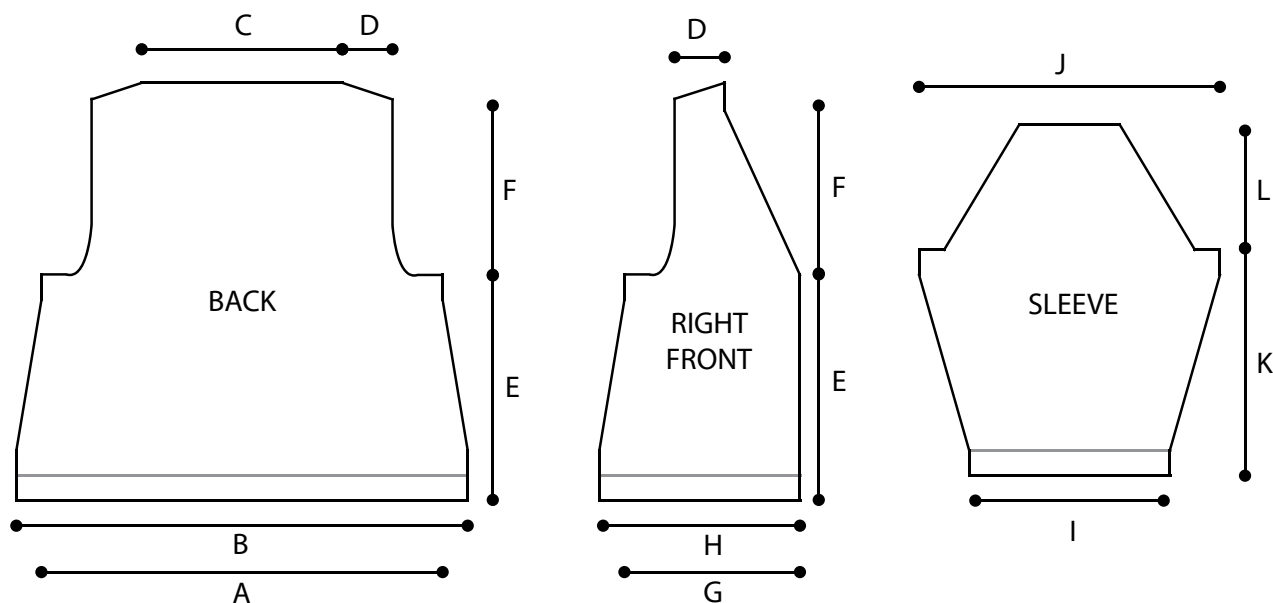

CORNISH MEASUREMENTS

A (Back Bust Width): (16, 18, 20) [22, 24, 26, 28] {30, 32, 34}" / (40.5, 45.5, 51) [56, 61, 66, 71] {76, 81.5, 86.5} cm

B (Back Hem Width): (18, 20½, 22) [24½, 26, 28½, 30] {32½, 34, 36½}" / (45.5, 52, 56) [62, 66, 72.5, 76] {82.5, 86.5, 92.5} cm

C (Neck Width): 8" / 20.5 cm

D (Shoulder Width): (2, 2½, 2¾) [3½, 3½, 3¾, 4] {4½, 4¾, 5}" / (5, 6.5, 7) [9, 9, 9.5, 10] {11.5, 12, 12.5} cm

E (Length to Underarm): (9, 9, 9) [9½, 9½, 10, 10] {10, 10, 10}" / (23, 23, 23) [24, 24, 25.5, 25.5] {25.5, 25.5, 25.5} cm

F (Armhole Length): (7, 7, 7½) [8, 8½, 9, 9½] {9½, 10, 10½}" / (18, 18, 19) [20.5, 21.5, 23, 24] {24, 25.5, 26.5} cm

G (Front Bust Width): (6½, 7½, 8½) [9½, 10½, 11½, 12½] {13½, 14½, 15½}" / (16.5, 19, 21.5) [24, 26.5, 29, 32] {34.5, 37, 39.5} cm

H (Front Hem Width): (7½, 8½, 10) [10¾, 11½, 12½, 14] {14¾, 15½, 16½}" / (19, 21.5, 25.5) [27.5, 29, 32, 35.5] {37.5, 39.5, 42} cm

I (Lower Sleeve Width): (8½, 8½, 9¼) [9¼, 10, 10, 10¾] {10¾, 11½, 11½}" / (21.5, 21.5, 23.5) [23.5, 25.5, 25.5, 27.5] {27.5, 29, 29} cm

J (Upper Sleeve Width): (12, 12½, 13¼) [14½, 15½, 16½, 17½] {18½, 19¼, 20}" / (30.5, 32, 33.5) [37, 39.5, 42, 44.5] {47, 49, 51} cm

K (Sleeve Length to Underarm): 9½" / 24 cm

L (Sleeve Cap Length): (5½, 5½, 6) [6¼, 6¾, 7¼, 7½] {7¼, 7¾, 8¼}" / (14, 14, 15) [16, 17, 18.5, 19] {18.5, 19.5, 21} cm



STANDARD ABBREVIATIONS & TERMS

beg: beginning

CC: contrasting color

CDD: Centered Double Decrease—Slip 2 together (as if to k2tog), knit 1, pass the 2 slipped stitches over

cn: cable needle

dec: decrease

dpn(s): double pointed needle(s)

end on WS: end having just completed a Wrong Side row.

end on RS: end having just completed a Right Side row

Garner St: Knit EVERY row when working back and forth in rows. Knit 1 round, purl 1 round when working in the round.

inc: increase

k: knit

k tbl: knit through the back loop(s)

k2tog: knit 2 stitches together

k3tog: knit 3 stitches together

kfb: knit in the front and back of the next st

LH: left hand

LLI: Left Lifted Increase—Insert LH needle into the purl bump one row below the st just worked on the RH needle and knit into this st (1 st inc'd)

M1: Make 1—Pick up horizontal strand between stitch just worked and next stitch from front to back, place on left hand needle, knit this stitch through the back (1 stitch increased).

M1L: Make 1 Left—Work as for M1.

M1p: Make 1 purl—Pick up horizontal strand between stitch just worked and next stitch from front to back, place on left hand needle, purl this stitch through the back (1 stitch increased).

M1pL: Make 1 purl Left—Work as for M1p.

M1pR: Make 1 purl Right—Pick up horizontal strand between stitch just worked and next stitch from back to front, place on left hand needle, purl this stitch through the front (1 stitch increased).

M1R: Make 1 Right—Pick up horizontal strand between stitch just worked and next stitch from back to front, place on left hand needle, knit this stitch through the front (1 stitch increased).

MC: main color

p: purl

p tbl: purl through the back loop(s)

p2tog: purl 2 stitches together

p3tog: purl 3 stitches together

pat(s): pattern(s)

pm: place marker

pssso: pass slipped stitch over knit stitch

rep: repeat

Rev St st: Reverse Stockinette Stitch—Purl 1 row, knit 1 row alternately when working back and forth in rows. The purl side is the right side of the work. Purl EVERY round when working in the round.

RH: right hand

RLI: Right Lifted Increase—Insert RH needle into the purl bump of the next st on the LH needle and knit into this st (1 st inc'd)

rnd(s): round(s)

RS: right side

sl: slip

sm: slip marker

SSK: Slip 2 stitches knitwise, insert point of left hand needle through fronts of these 2 stitches and knit 2 together.

SSP: Slip 2 stitches knitwise, transfer these 2 stitches back to left hand needle, purl 2 together through the back loops.

SSSK: Slip 3 stitches knitwise, insert point of left hand needle through fronts of these 3 stitches and knit 3 together.

st(s): stitch(es)

St st: Stockinette Stitch—Knit 1 row, purl 1 row alternately when working back and forth in rows. The knit side is the right side of work. Knit EVERY round when working in the round.

tbl: through back loop(s)

w&t: wrap and turn, a method of concealing a hole created in short row shaping. On RS rows: With yarn held in front, slip next stitch purlwise, then bring yarn between needles to the back. Slip that same stitch back to the left needle. Turn your work. On WS Rows: With yarn held in back, slip next stitch purlwise, then bring yarn between needles to the front. Slip that same stitch back to the left needle. Turn your work. Unless otherwise indicated, each time you come to a wrapped stitch when working subsequent rows, slip the wrap back over stitch and onto needle, then work the wrap together with its accompanying stitch.

WS: wrong side

wyib: with yarn in back

wyif: with yarn in front

yo: yarn over

*Love Berroco patterns?
Sign up for our **KnitBits®** newsletter.*

