



ELEVATE

Reference Drawings & Instructions

Item #895840-XX1



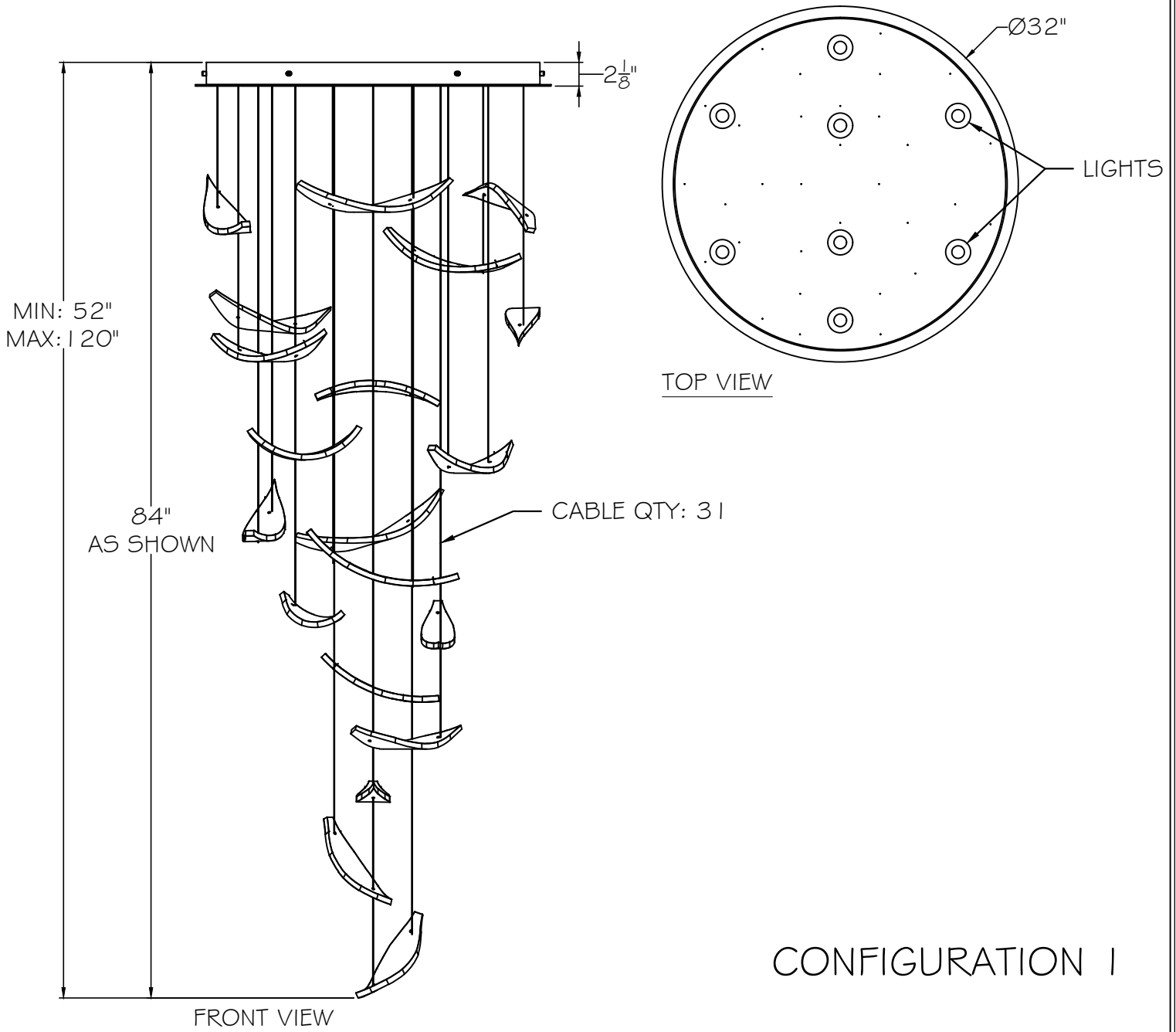

32" Round Canopy Configuration 1
(For Tall Ceilings) All Glass Options

For specific glass option, refer to style number listed on the bottom of instruction pages.

CUSTOMER REFERENCE DRAWING - CONFIGURATION 1 - FOR HIGH CEILINGS

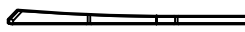
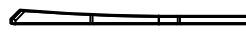
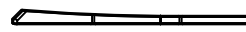

THUMBNAIL IMAGES OF STYLE OPTIONS:

<p>-111 SILVER -211 GOLD</p>  <p>GLASS PLUME W/ DICHRO (X20)</p>	<p>-121 SILVER -221 GOLD</p>  <p>GLASS PLUME NO DICHRO (X20)</p>	<p>-131 SILVER -231 GOLD</p>  <p>GLASS SPIRE CLEAR (X23)</p>	<p>-141 SILVER -241 GOLD</p>  <p>GLASS SPIRE BLACK (X23)</p>	<p>-151 SILVER -251 GOLD</p>  <p>GLASS SPIRE METEORITE (X23)</p>
<p>-161 SILVER -261 GOLD</p>  <p>FROZEN PAGES (FRIT) (X20)</p>	<p>-171 SILVER -271 GOLD</p>  <p>BLANK PAGES (WHITE) (X20)</p>			



This drawing, specifications and the product depicted are the exclusive property of Fine Art Handcrafted Lighting®. In compliance with US copyright and patent requirements, notice is hereby given that this document and the product depicted shall not be copied, altered or used in any manner without the expressed written consent of Fine Art Handcrafted Lighting®.

www.finearthl.com

Tel:(305) 821-3850
FINE ART LAMPS®

Fax:(305) 513-5736

STYLE NUMBER:

895840

DATE:

2 of 17

INSTRUCTIONS for PLUMES (Dichro & White)

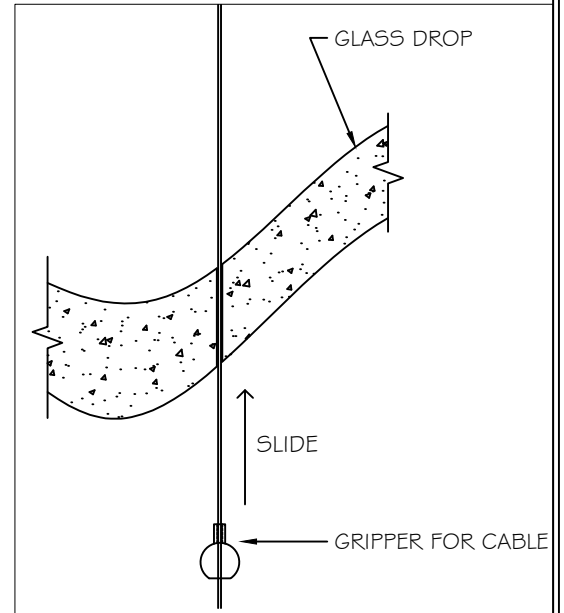
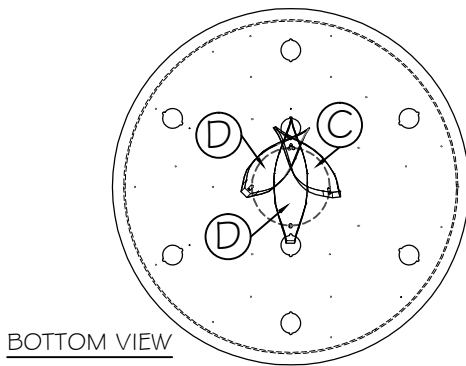
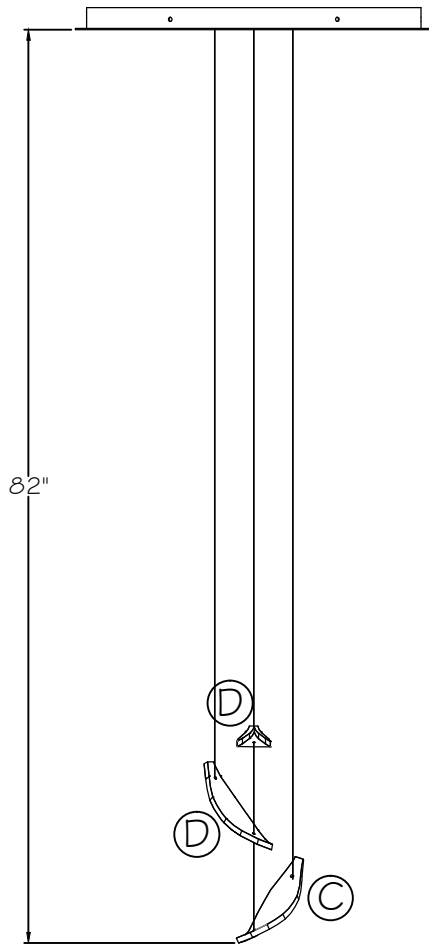
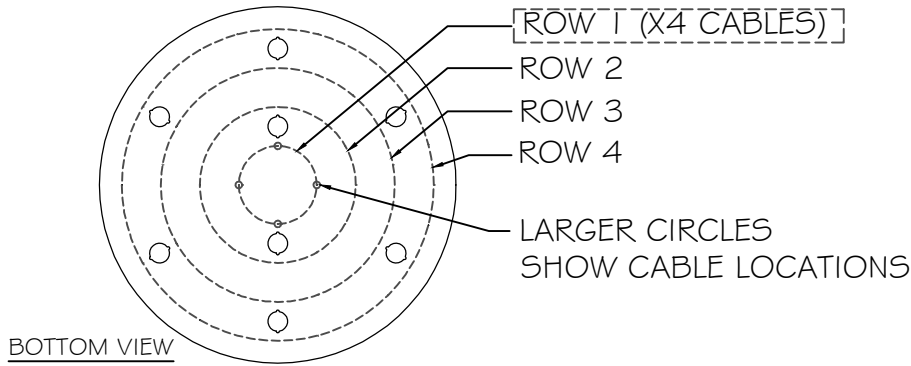

ROW 1

GLASS TYPE	QUANTITY
TYPE A	0
TYPE B	0
TYPE C	1
TYPE D	2

- ROW 1 OF GLASSES TO BE INSTALLED FIRST.
- GATHER ALL OTHER CABLES TO EASILY ACCESS LAYER TO BE WORKED ON
- LETTERS IN CIRCLES ON DIAGRAM INDICATE GLASS TYPE THAT CORRESPONDS TO STICKERS ON GLASS
- START SLIDING GLASSES UP INTO POSITION AS SHOWN ON FRONT VIEW, STARTING FROM TOP TO BOTTOM
- SLIDE GRIPPER UP TO HOLD POSITION OF GLASS
- NOTE: MULTIPLE GLASSES MAY USE THE SAME CABLES

STYLE(S) #: 895840-111 -211 -121 -221



This drawing, specifications and the product depicted are the exclusive property of Fine Art Handcrafted Lighting®. In compliance with US copyright and patent requirements, notice is hereby given that this document and the product depicted shall not be copied, altered or used in any manner without the expressed written consent of Fine Art Handcrafted Lighting®.

www.finearthl.com

Tel:(305) 821-3850
 FINE ART LAMPS®

Fax:(305) 513-5736

INSTRUCTION #:

00791414

SHEET

3 of 17

INSTRUCTIONS for PLUMES (Dichro & White)

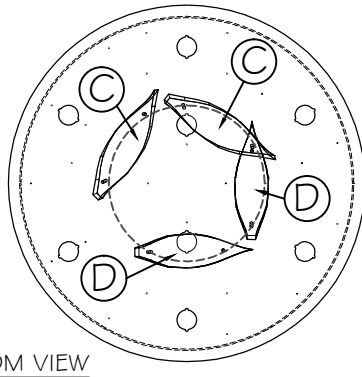
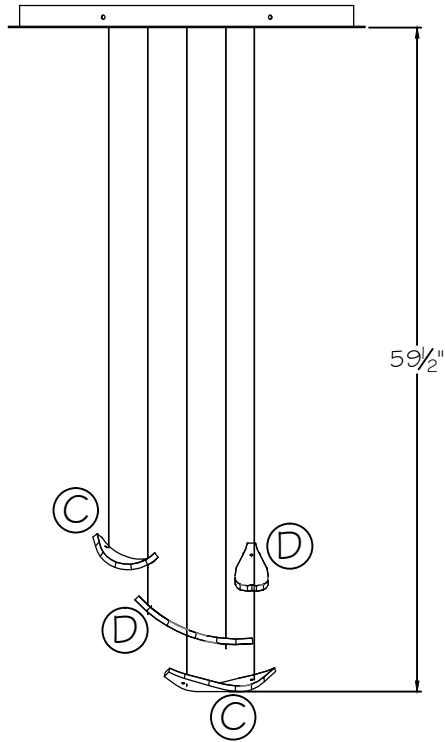
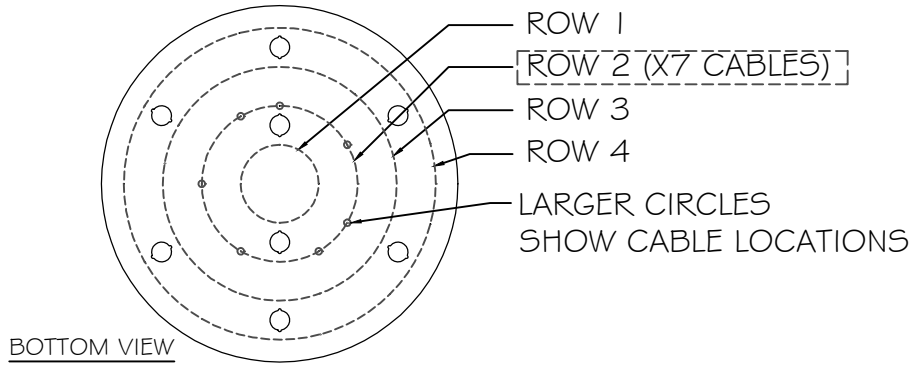

ROW 2

GLASS TYPE	QUANTITY
TYPE A	0
TYPE B	0
TYPE C	2
TYPE D	2

- ROW 2 OF GLASSES TO BE INSTALLED NEXT.
- START SLIDING GLASSES UP INTO POSITION AS SHOWN ON FRONT VIEW, STARTING FROM TOP TO BOTTOM
- SLIDE GRIPPER UP TO HOLD POSITION OF GLASS
- NOTE: MULTIPLE GLASSES MAY USE THE SAME CABLES

STYLE(S) #: 895840-111 -211 -121 -221



This drawing, specifications and the product depicted are the exclusive property of Fine Art Handcrafted Lighting®. In compliance with US copyright and patent requirements, notice is hereby given that this document and the product depicted shall not be copied, altered or used in any manner without the expressed written consent of Fine Art Handcrafted Lighting®.

www.finearthl.com

Tel:(305) 821-3850
FINE ART LAMPS®

Fax:(305) 513-5736

INSTRUCTION #:

00791414

SHEET

4 of 17

INSTRUCTIONS for PLUMES (Dichro & White)

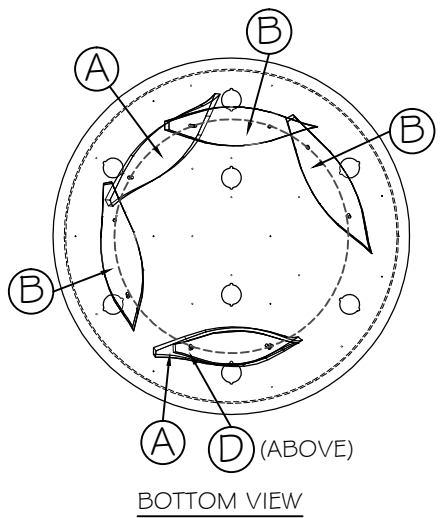
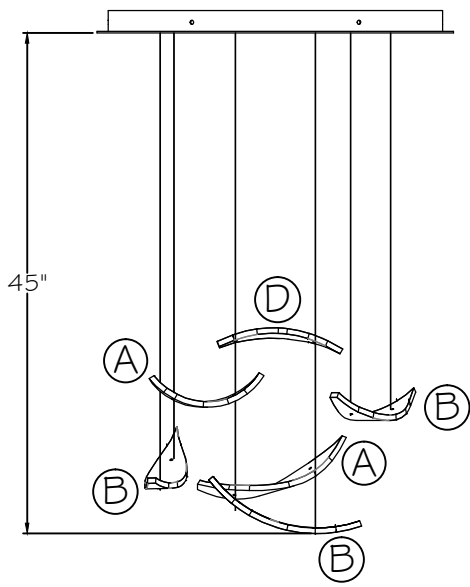
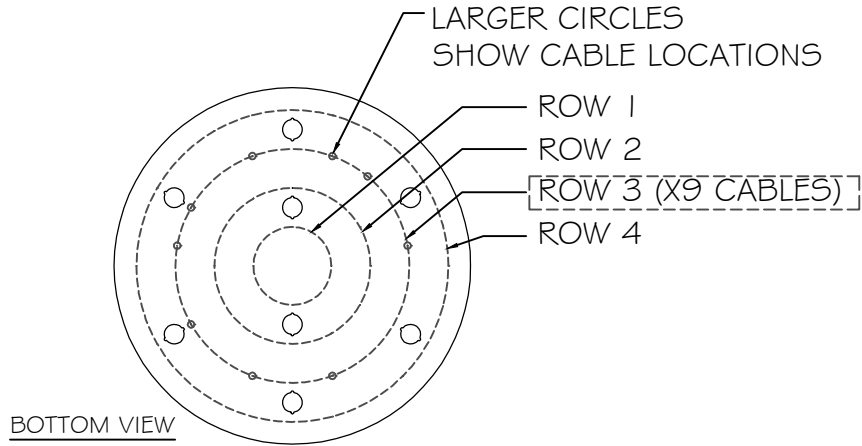

ROW 3	
GLASS TYPE	QUANTITY
TYPE A	2
TYPE B	3
TYPE C	0
TYPE D	1

- ROW 3 OF GLASSES TO BE INSTALLED NEXT.
- START SLIDING GLASSES UP INTO POSITION AS SHOWN ON FRONT VIEW, STARTING FROM TOP TO BOTTOM
- SLIDE GRIPPER UP TO HOLD POSITION OF GLASS
- NOTE: MULTIPLE GLASSES MAY USE THE SAME CABLES

STYLE(S) #: 895840-111 -211 -121 -221



This drawing, specifications and the product depicted are the exclusive property of Fine Art Handcrafted Lighting®. In compliance with US copyright and patent requirements, notice is hereby given that this document and the product depicted shall not be copied, altered or used in any manner without the expressed written consent of Fine Art Handcrafted Lighting®.

www.finearthl.com Tel:(305) 821-3850 Fax:(305) 513-5736
FINE ART LAMPS®

INSTRUCTION #:
00791414

SHEET
5 of 17

INSTRUCTIONS for PLUMES (Dichro & White)

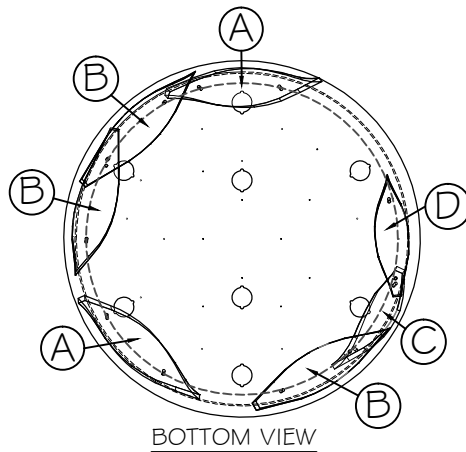
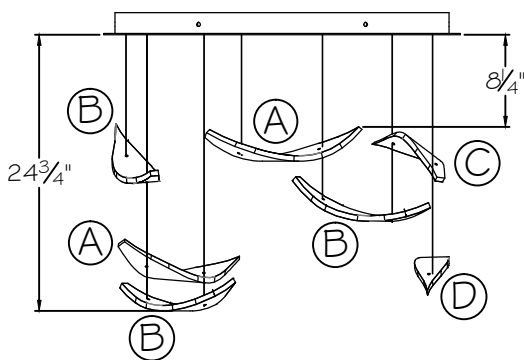
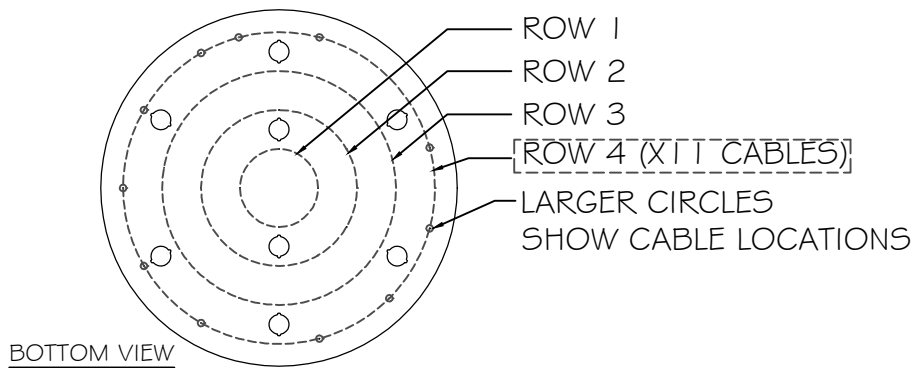

ROW 4	
GLASS TYPE	QUANTITY
TYPE A	2
TYPE B	3
TYPE C	1
TYPE D	1

- ROW 4 OF GLASSES TO BE INSTALLED NEXT.
- START SLIDING GLASSES UP INTO POSITION AS SHOWN ON FRONT VIEW, STARTING FROM TOP TO BOTTOM
- SLIDE GRIPPER UP TO HOLD POSITION OF GLASS
- NOTE: MULTIPLE GLASSES MAY USE THE SAME CABLES

STYLE(S) #: 895840-111 -211 -121 -221



This drawing, specifications and the product depicted are the exclusive property of Fine Art Handcrafted Lighting®. In compliance with US copyright and patent requirements, notice is hereby given that this document and the product depicted shall not be copied, altered or used in any manner without the expressed written consent of Fine Art Handcrafted Lighting®.

www.finearthl.com

Tel:(305) 821-3850
FINE ART LAMPS®

Fax:(305) 513-5736

INSTRUCTION #:

00791414

SHEET

6 of 17

INSTRUCTIONS for PLUMES (Dichro & White)

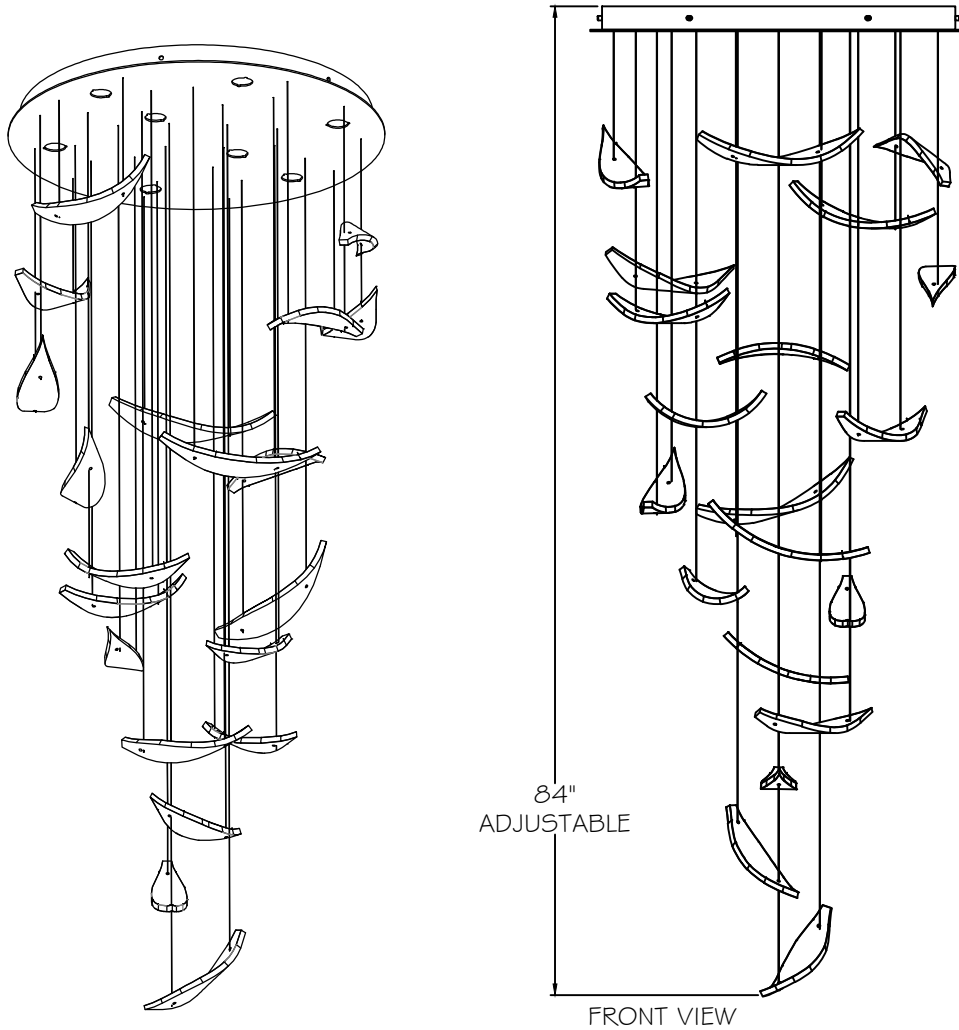

- ONCE ALL GLASSES ARE INSTALLED AND FINAL GLASS POSITION IS ACHIEVED, ENSURE TO CUT EXCESS CABLES UP TO HARDWARE OF LOWEST GLASSES. REFERENCE INSTALLATION INSTRUCTIONS.

STYLE(S) #: 895840-111 -211 -121 -221

**FINE
ART**
HANDCRAFTED LIGHTING

This drawing, specifications and the product depicted are the exclusive property of Fine Art Handcrafted Lighting®. In compliance with US copyright and patent requirements, notice is hereby given that this document and the product depicted shall not be copied, altered or used in any manner without the expressed written consent of Fine Art Handcrafted Lighting®.

www.finearthl.com

Tel:(305) 821-3850
FINE ART LAMPS®

Fax:(305) 513-5736

INSTRUCTION #:

00791414

SHEET

7 of 17

INSTRUCTIONS for SPIRES GLASS OPTIONS (Meteorite, Crystal Stardust & Ebony Stardust)

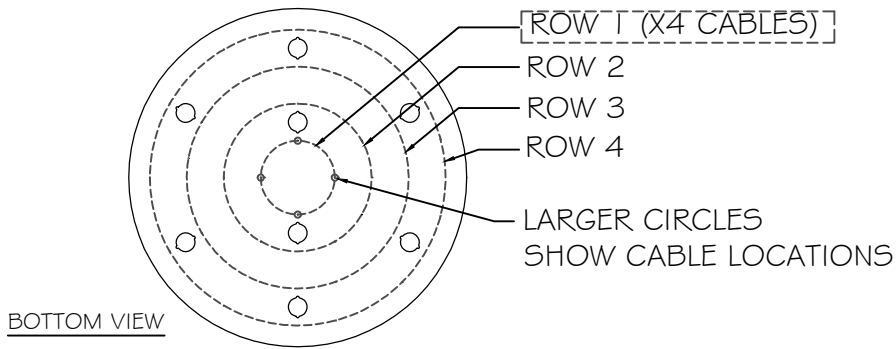

BOTTOM VIEW

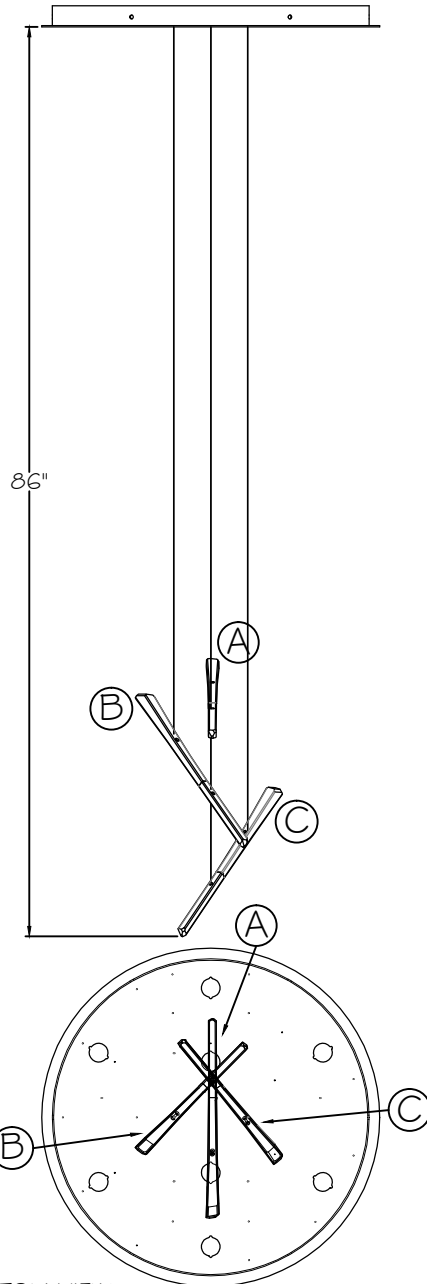

BOTTOM VIEW

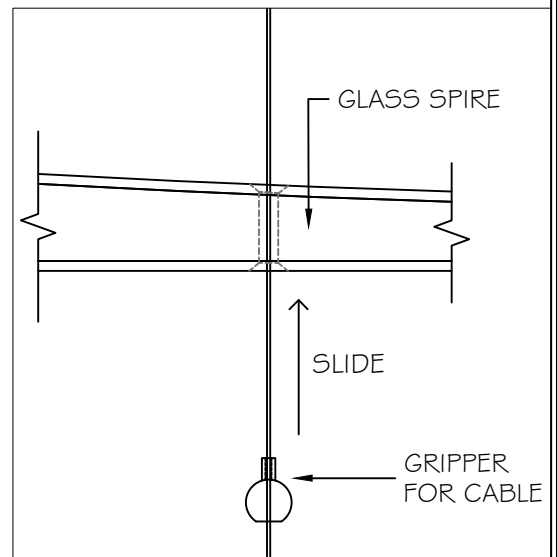

- ROW 1 OF GLASSES TO BE INSTALLED FIRST.
- GATHER ALL OTHER CABLES TO EASILY ACCESS LAYER TO BE WORKED ON
- START SLIDING GLASSES UP INTO POSITION AS SHOWN ON FRONT VIEW, STARTING FROM TOP TO BOTTOM
- SLIDE GRIPPER UP TO HOLD POSITION OF GLASS
- NOTE: MULTIPLE GLASSES MAY USE THE SAME CABLES

STYLE(S) #: 895840-131 -231 -141 -241 -151 -251



This drawing, specifications and the product depicted are the exclusive property of Fine Art Handcrafted Lighting®. In compliance with US copyright and patent requirements, notice is hereby given that this document and the product depicted shall not be copied, altered or used in any manner without the expressed written consent of Fine Art Handcrafted Lighting®.

www.finearthl.com

Tel:(305) 821-3850
FINE ART LAMPS®

Fax:(305) 513-5736

INSTRUCTION #:

00791416

SHEET

8 of 17

INSTRUCTIONS for SPIRES GLASS OPTIONS (Meteorite, Crystal Stardust & Ebony Stardust)

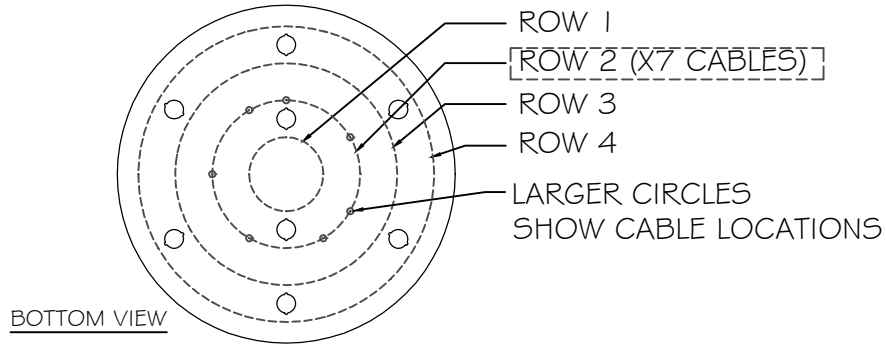

BOTTOM VIEW

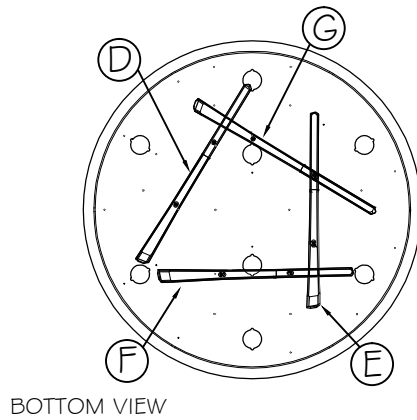
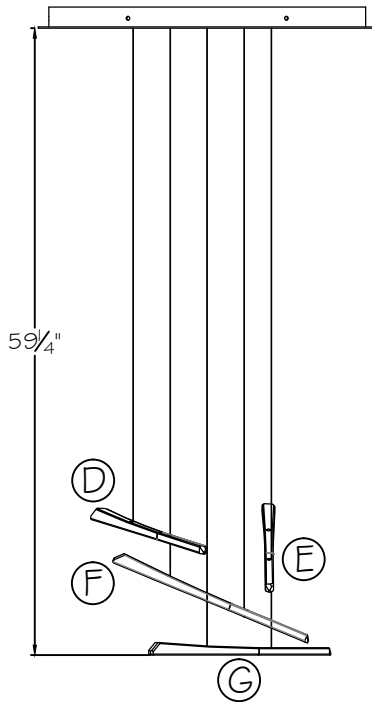

BOTTOM VIEW

- ROW 2 OF GLASSES TO BE INSTALLED FIRST.
- GATHER ALL OTHER CABLES TO EASILY ACCESS LAYER TO BE WORKED ON
- START SLIDING GLASSES UP INTO POSITION AS SHOWN ON FRONT VIEW, STARTING FROM TOP TO BOTTOM
- SLIDE GRIPPER UP TO HOLD POSITION OF GLASS
- NOTE: MULTIPLE GLASSES MAY USE THE SAME CABLES

STYLE(S) #: 895840-131 -231 -141 -241 -151 -251



This drawing, specifications and the product depicted are the exclusive property of Fine Art Handcrafted Lighting®. In compliance with US copyright and patent requirements, notice is hereby given that this document and the product depicted shall not be copied, altered or used in any manner without the expressed written consent of Fine Art Handcrafted Lighting®.

www.finearthl.com Tel:(305) 821-3850 Fax:(305) 513-5736
FINE ART LAMPS®

INSTRUCTION #:
00791416

SHEET
9 of 17

INSTRUCTIONS for SPIRES GLASS OPTIONS (Meteorite, Crystal Stardust & Ebony Stardust)

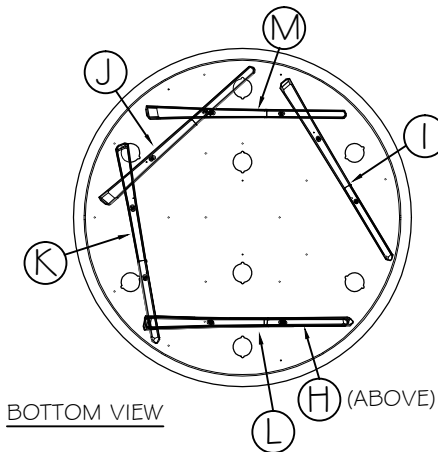
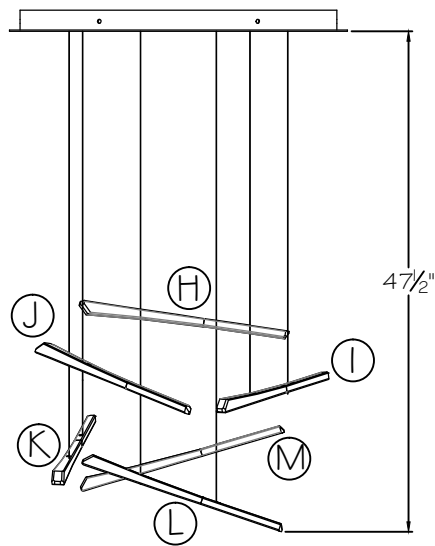
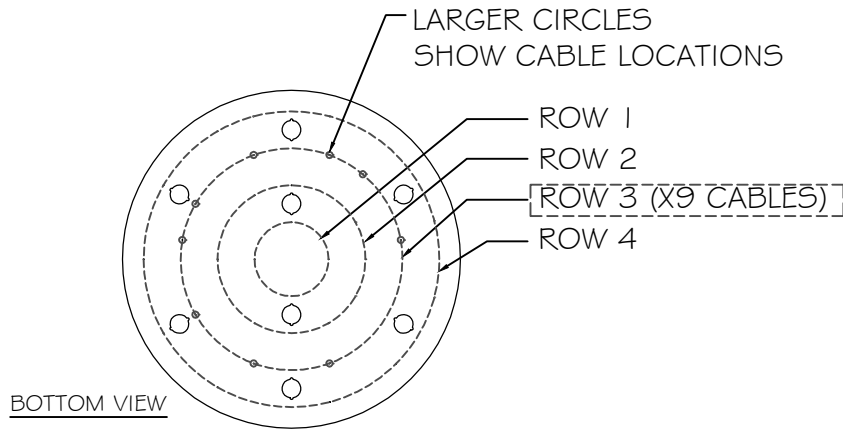

- ROW 3 OF GLASSES TO BE INSTALLED FIRST.
- GATHER ALL OTHER CABLES TO EASILY ACCESS LAYER TO BE WORKED ON
- START SLIDING GLASSES UP INTO POSITION AS SHOWN ON FRONT VIEW, STARTING FROM TOP TO BOTTOM
- SLIDE GRIPPER UP TO HOLD POSITION OF GLASS
- NOTE: MULTIPLE GLASSES MAY USE THE SAME CABLES

STYLE(S) #: 895840-131 -231 -141 -241 -151 -251



This drawing, specifications and the product depicted are the exclusive property of Fine Art Handcrafted Lighting®. In compliance with US copyright and patent requirements, notice is hereby given that this document and the product depicted shall not be copied, altered or used in any manner without the expressed written consent of Fine Art Handcrafted Lighting®.

www.finearthl.com

Tel:(305) 821-3850
FINE ART LAMPS®

Fax:(305) 513-5736

INSTRUCTION #:

00791416

SHEET

10 of 17

INSTRUCTIONS for SPIRES GLASS OPTIONS (Meteorite, Crystal Stardust & Ebony Stardust)

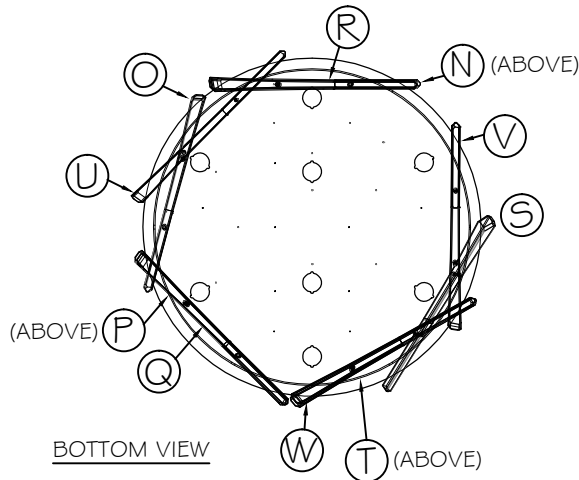
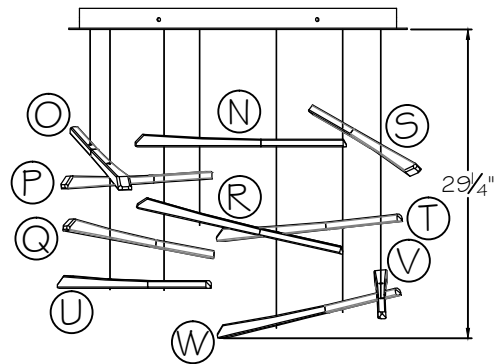
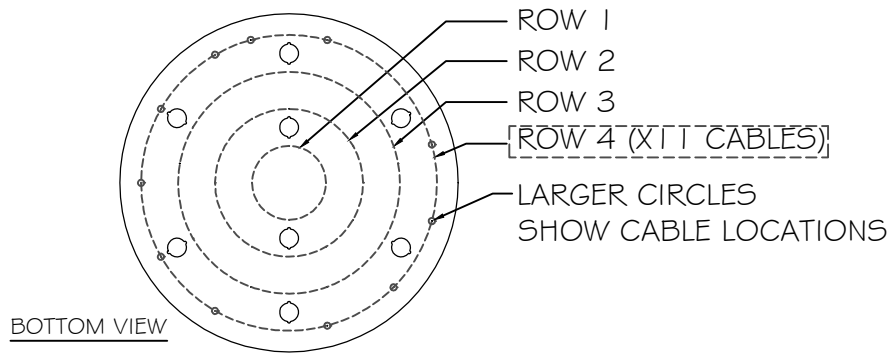

- ROW 4 OF GLASSES TO BE INSTALLED FIRST.
- GATHER ALL OTHER CABLES TO EASILY ACCESS LAYER TO BE WORKED ON
- START SLIDING GLASSES UP INTO POSITION AS SHOWN ON FRONT VIEW, STARTING FROM TOP TO BOTTOM
- SLIDE GRIPPER UP TO HOLD POSITION OF GLASS
- NOTE: MULTIPLE GLASSES MAY USE THE SAME CABLES

STYLE(S) #: 895840-131 -231 -141 -241 -151 -251



This drawing, specifications and the product depicted are the exclusive property of Fine Art Handcrafted Lighting®. In compliance with US copyright and patent requirements, notice is hereby given that this document and the product depicted shall not be copied, altered or used in any manner without the expressed written consent of Fine Art Handcrafted Lighting®.

www.finearthl.com

Tel:(305) 821-3850
FINE ART LAMPS®

Fax:(305) 513-5736

INSTRUCTION #:

00791416

SHEET

11 of 17

INSTRUCTIONS for SPIRES GLASS OPTIONS (Meteorite, Crystal Stardust & Ebony Stardust)

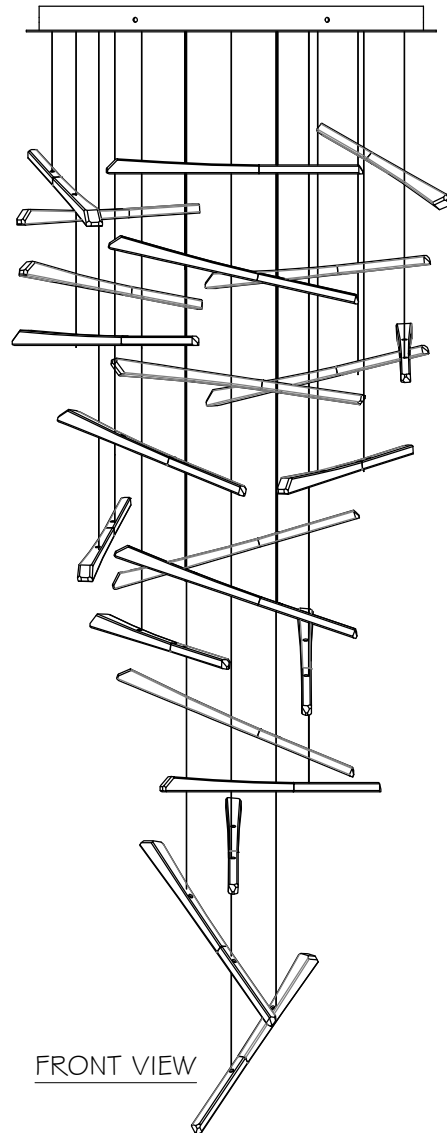
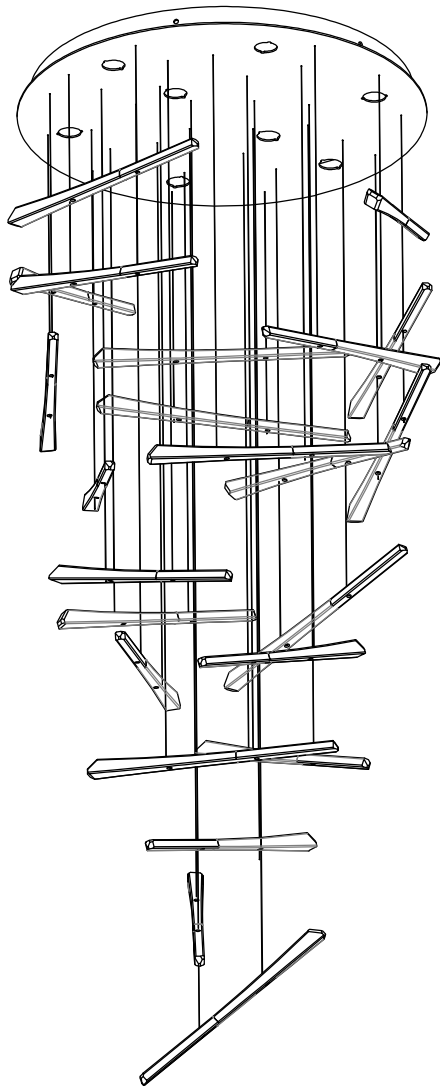

FRONT VIEW

- ONCE ALL GLASSES ARE INSTALLED AND FINAL GLASS POSITION IS ACHIEVED, ENSURE TO CUT EXCESS CABLES UP TO HARDWARE OF LOWEST GLASSES. REFERENCE INSTALLATION INSTRUCTIONS.

STYLE(S) #: 895840-131 -231 -141 -241 -151 -251



This drawing, specifications and the product depicted are the exclusive property of Fine Art Handcrafted Lighting®. In compliance with US copyright and patent requirements, notice is hereby given that this document and the product depicted shall not be copied, altered or used in any manner without the expressed written consent of Fine Art Handcrafted Lighting®.

www.finearthl.com

Tel:(305) 821-3850
FINE ART LAMPS®

Fax:(305) 513-5736

INSTRUCTION #:

00791416

SHEET

12 of 17

INSTRUCTIONS for PAGES GLASS OPTIONS (Frozen & Blank)

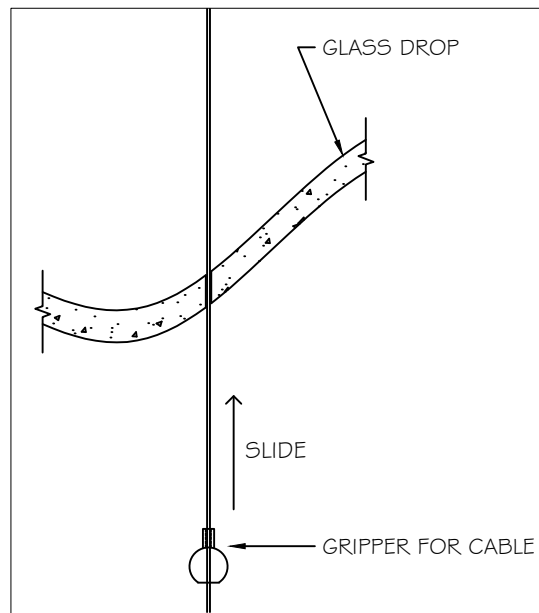
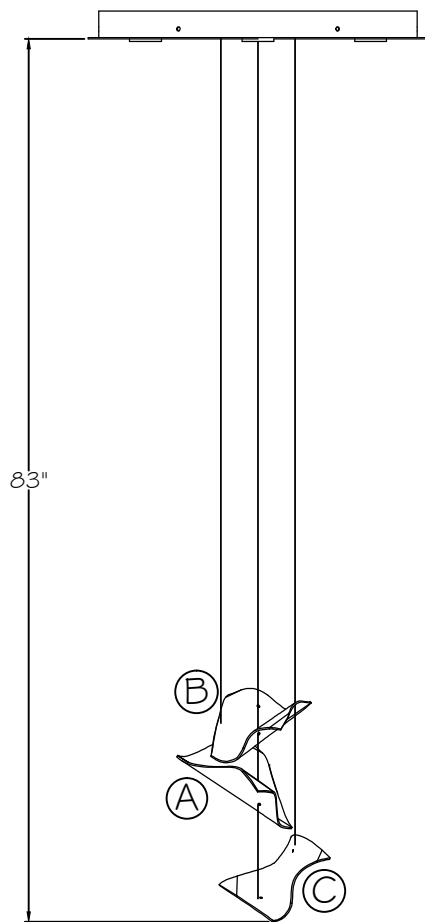
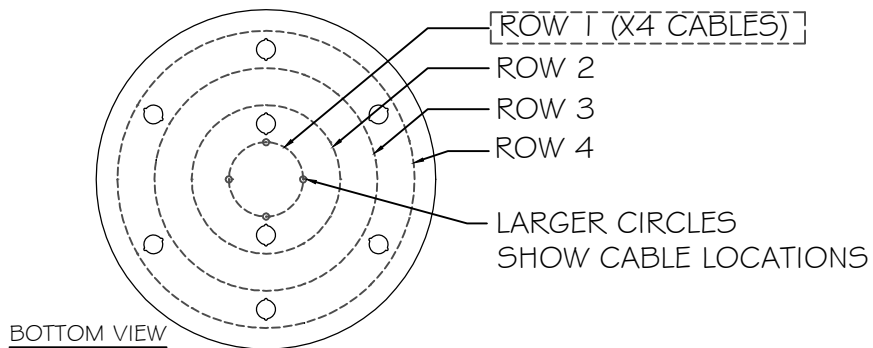

ROW 1

GLASS TYPE	QUANTITY
TYPE A	1
TYPE B	1
TYPE C	1

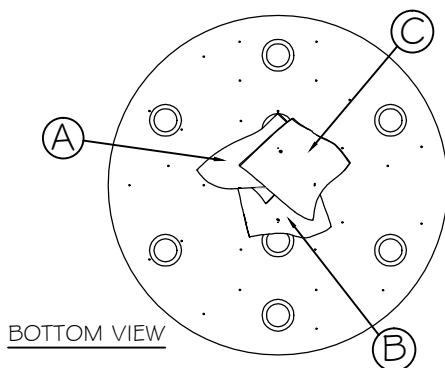

- ROW 1 OF GLASSES TO BE INSTALLED FIRST.
- GATHER ALL OTHER CABLES TO EASILY ACCESS LAYER TO BE WORKED ON
- LETTERS IN CIRCLES ON DIAGRAM INDICATE GLASS TYPE THAT CORRESPONDS TO STICKERS ON GLASS
- START SLIDING GLASSES UP INTO POSITION AS SHOWN ON FRONT VIEW, STARTING FROM TOP TO BOTTOM
- SLIDE GRIPPER UP TO HOLD POSITION OF GLASS
- NOTE: MULTIPLE GLASSES MAY USE THE SAME CABLES

STYLE(S) #: 895840-161 -261 -171 -271



This drawing, specifications and the product depicted are the exclusive property of Fine Art Handcrafted Lighting®. In compliance with US copyright and patent requirements, notice is hereby given that this document and the product depicted shall not be copied, altered or used in any manner without the expressed written consent of Fine Art Handcrafted Lighting®.

www.finearthl.com Tel:(305) 821-3850 Fax:(305) 513-5736
 FINE ART LAMPS®

INSTRUCTION #:
00791497
 SHEET
 13 of 17

INSTRUCTIONS for PAGES GLASS OPTIONS (Frozen & Blank)

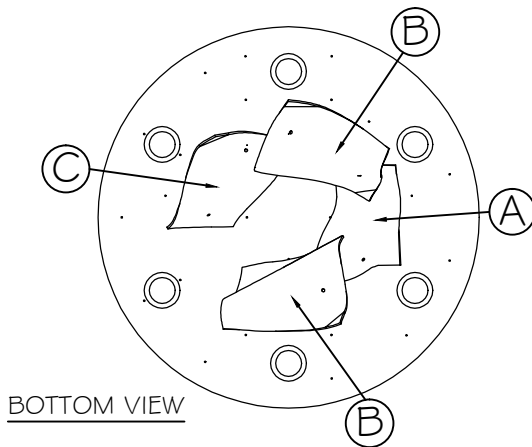
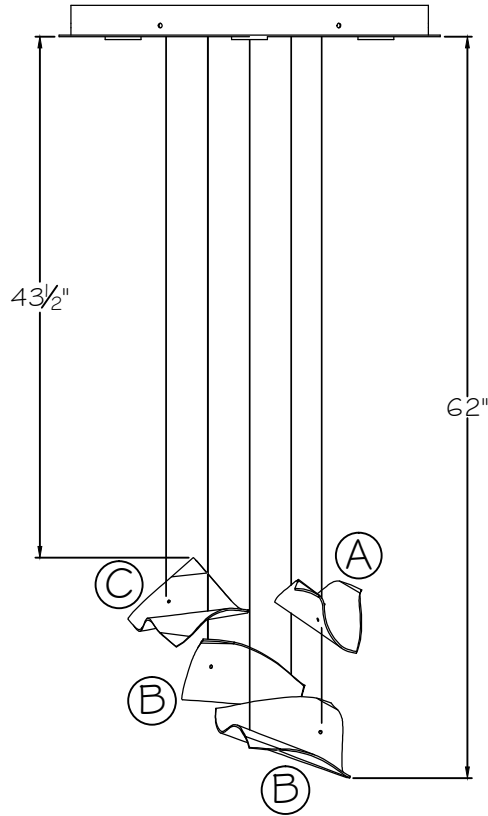
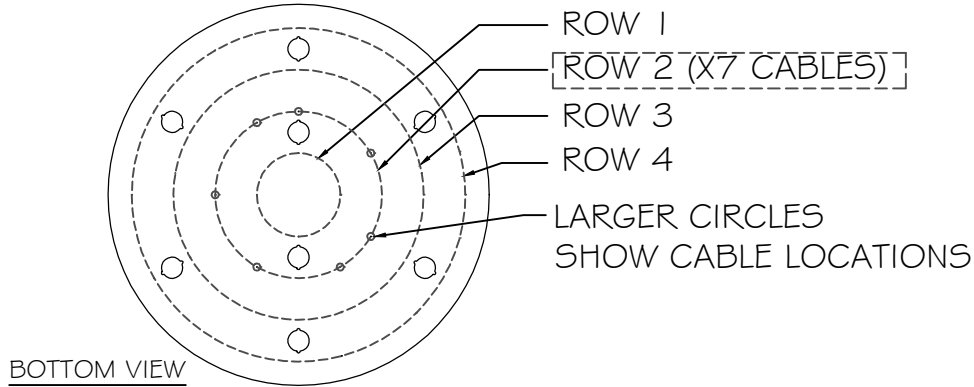

ROW 2	
GLASS TYPE	QUANTITY
TYPE A	1
TYPE B	2
TYPE C	1

- ROW 2 OF GLASSES TO BE INSTALLED NEXT.
- START SLIDING GLASSES UP INTO POSITION AS SHOWN ON FRONT VIEW, STARTING FROM TOP TO BOTTOM
- SLIDE GRIPPER UP TO HOLD POSITION OF GLASS
- NOTE: MULTIPLE GLASSES MAY USE THE SAME CABLES

STYLE(S) #: 895840-161 -261 -171 -271



This drawing, specifications and the product depicted are the exclusive property of Fine Art Handcrafted Lighting®. In compliance with US copyright and patent requirements, notice is hereby given that this document and the product depicted shall not be copied, altered or used in any manner without the expressed written consent of Fine Art Handcrafted Lighting®.

www.finearthl.com Tel:(305) 821-3850 Fax:(305) 513-5736
 FINE ART LAMPS®

INSTRUCTION #:
 00791497

SHEET
 14 of 17

INSTRUCTIONS for PAGES GLASS OPTIONS (Frozen & Blank)

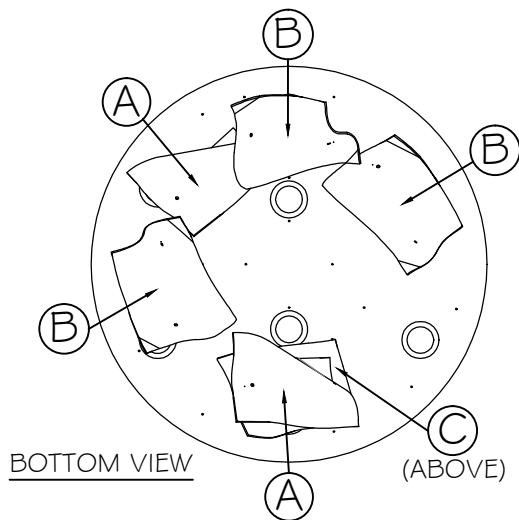
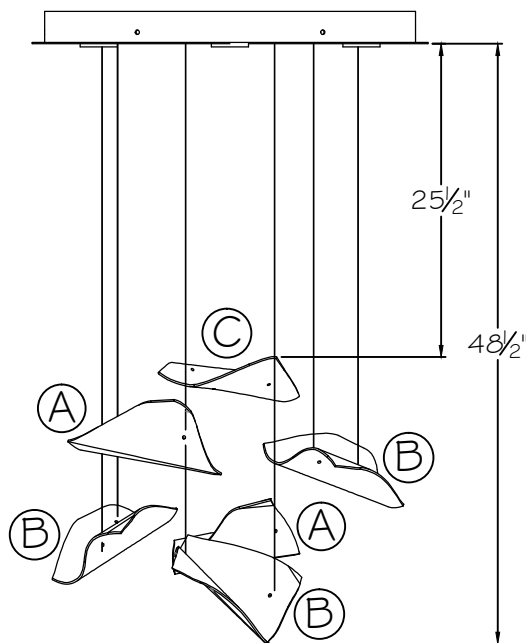
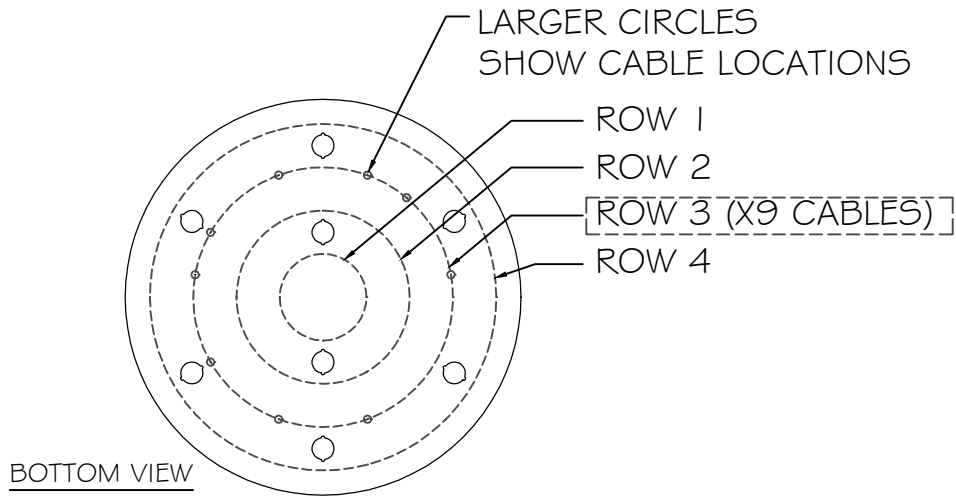

ROW 3	
GLASS TYPE	QUANTITY
TYPE A	2
TYPE B	3
TYPE C	1

- ROW 3 OF GLASSES TO BE INSTALLED NEXT.
- START SLIDING GLASSES UP INTO POSITION AS SHOWN ON FRONT VIEW, STARTING FROM TOP TO BOTTOM
- SLIDE GRIPPER UP TO HOLD POSITION OF GLASS
- NOTE: MULTIPLE GLASSES MAY USE THE SAME CABLES

STYLE(S) #: 895840-161 -261 -171 -271



This drawing, specifications and the product depicted are the exclusive property of Fine Art Handcrafted Lighting®. In compliance with US copyright and patent requirements, notice is hereby given that this document and the product depicted shall not be copied, altered or used in any manner without the expressed written consent of Fine Art Handcrafted Lighting®.

www.finearthl.com

Tel:(305) 821-3850
FINE ART LAMPS®

Fax:(305) 513-5736

INSTRUCTION #:

00791497

SHEET

15 of 17

INSTRUCTIONS for PAGES GLASS OPTIONS (Frozen & Blank)

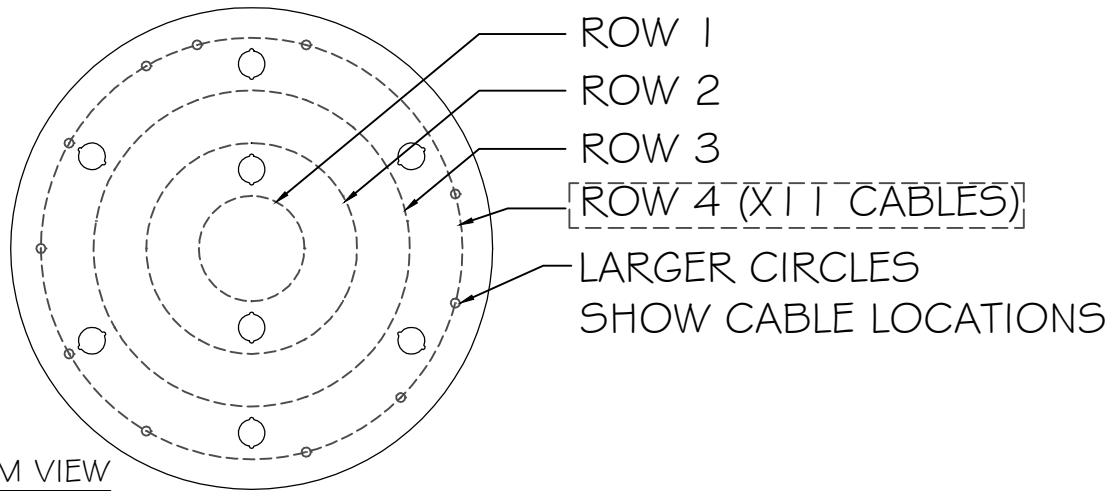

BOTTOM VIEW

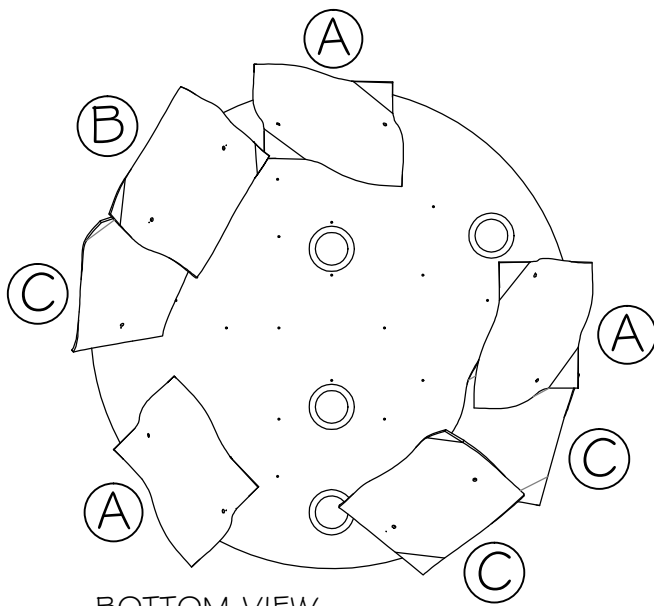
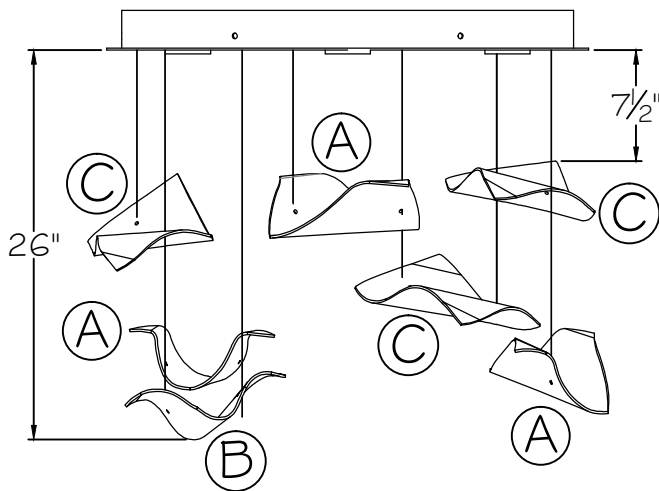

BOTTOM VIEW

ROW 4	
GLASS TYPE	QUANTITY
TYPE A	3
TYPE B	1
TYPE C	3

- ROW 4 OF GLASSES TO BE INSTALLED NEXT.
- START SLIDING GLASSES UP INTO POSITION AS SHOWN ON FRONT VIEW, STARTING FROM TOP TO BOTTOM
- SLIDE GRIPPER UP TO HOLD POSITION OF GLASS
- NOTE: MULTIPLE GLASSES MAY USE THE SAME CABLES

STYLE(S) #: 895840-161 -261 -171 -271



This drawing, specifications and the product depicted are the exclusive property of Fine Art Handcrafted Lighting®. In compliance with US copyright and patent requirements, notice is hereby given that this document and the product depicted shall not be copied, altered or used in any manner without the expressed written consent of Fine Art Handcrafted Lighting®.

www.finearthl.com

Tel:(305) 821-3850
FINE ART LAMPS®

Fax:(305) 513-5736

INSTRUCTION #:

00791497

SHEET

16 of 17

INSTRUCTIONS for PAGES GLASS OPTIONS (Frozen & Blank)

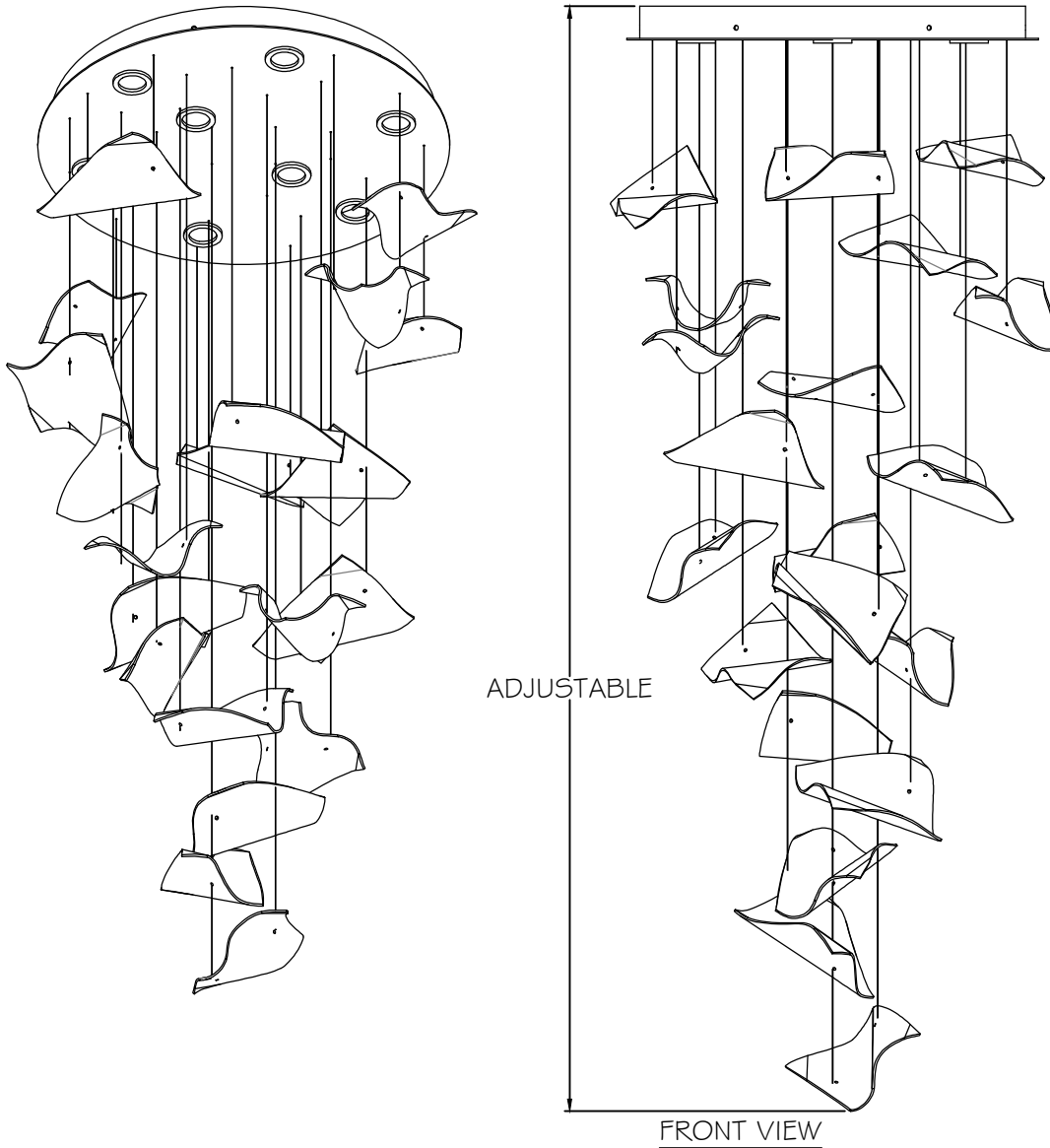

- ONCE ALL GLASSES ARE INSTALLED AND FINAL GLASS POSITION IS ACHIEVED, ENSURE TO CUT EXCESS CABLES UP TO HARDWARE OF LOWEST GLASSES. REFERENCE INSTALLATION INSTRUCTIONS.

STYLE(S) #: 895840-161 -261 -171 -271



This drawing, specifications and the product depicted are the exclusive property of Fine Art Handcrafted Lighting®. In compliance with US copyright and patent requirements, notice is hereby given that this document and the product depicted shall not be copied, altered or used in any manner without the expressed written consent of Fine Art Handcrafted Lighting®.

www.finearthl.com

Tel:(305) 821-3850
FINE ART LAMPS®

Fax:(305) 513-5736

INSTRUCTION #:

00791497

SHEET

17 of 17