



## ELEVATE

# Reference Drawings & Instructions

Item #895140-XX1

48" Rectangular Canopy





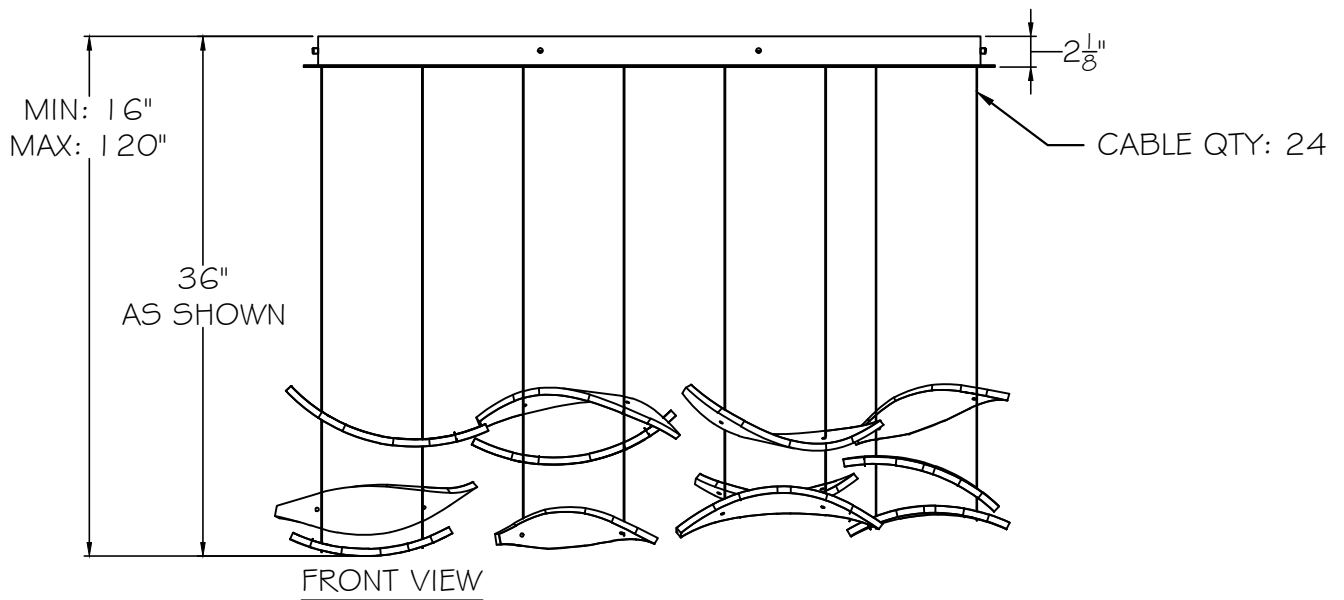
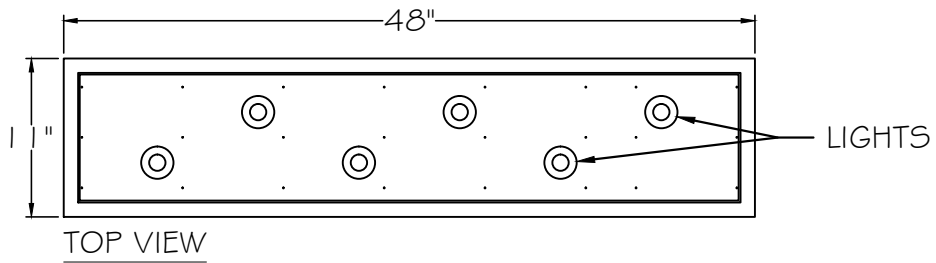

All Glass Options

For specific glass option, refer to style number listed on the bottom of instruction pages.

CUSTOMER REFERENCE DRAWING



THUMBNAIL IMAGES OF STYLE OPTIONS:

<p>-111 SILVER -211 GOLD</p>  <p>GLASS PLUME W/ DICHRO (X12)</p>	<p>-121 SILVER -221 GOLD</p>  <p>GLASS PLUME NO DICHRO (X12)</p>	<p>-131 SILVER -231 GOLD</p>  <p>GLASS SPIRE CLEAR (X18)</p>	<p>-141 SILVER -241 GOLD</p>  <p>GLASS SPIRE BLACK (X18)</p>	<p>-151 SILVER -251 GOLD</p>  <p>GLASS SPIRE METEORITE (X18)</p>
<p>-161 SILVER -261 GOLD</p>  <p>FROZEN PAGES (FRIT) (X12)</p>	<p>-171 SILVER -271 GOLD</p>  <p>BLANK PAGES (WHITE) (X12)</p>			



This drawing, specifications and the product depicted are the exclusive property of Fine Art Handcrafted Lighting®. In compliance with US copyright and patent requirements, notice is hereby given that this document and the product depicted shall not be copied, altered or used in any manner without the expressed written consent of Fine Art Handcrafted Lighting®.

www.finearthl.com

Tel:(305) 821-3850  
FINE ART LAMPS®

Fax:(305) 513-5736

STYLE NUMBER:

895140

DATE:

10/13/2020

# INSTRUCTIONS for PLUME GLASS OPTIONS

**NOTE: ORIENTATION OF CANOPY IS CRITICAL TO GLASS DROP DESIGN**

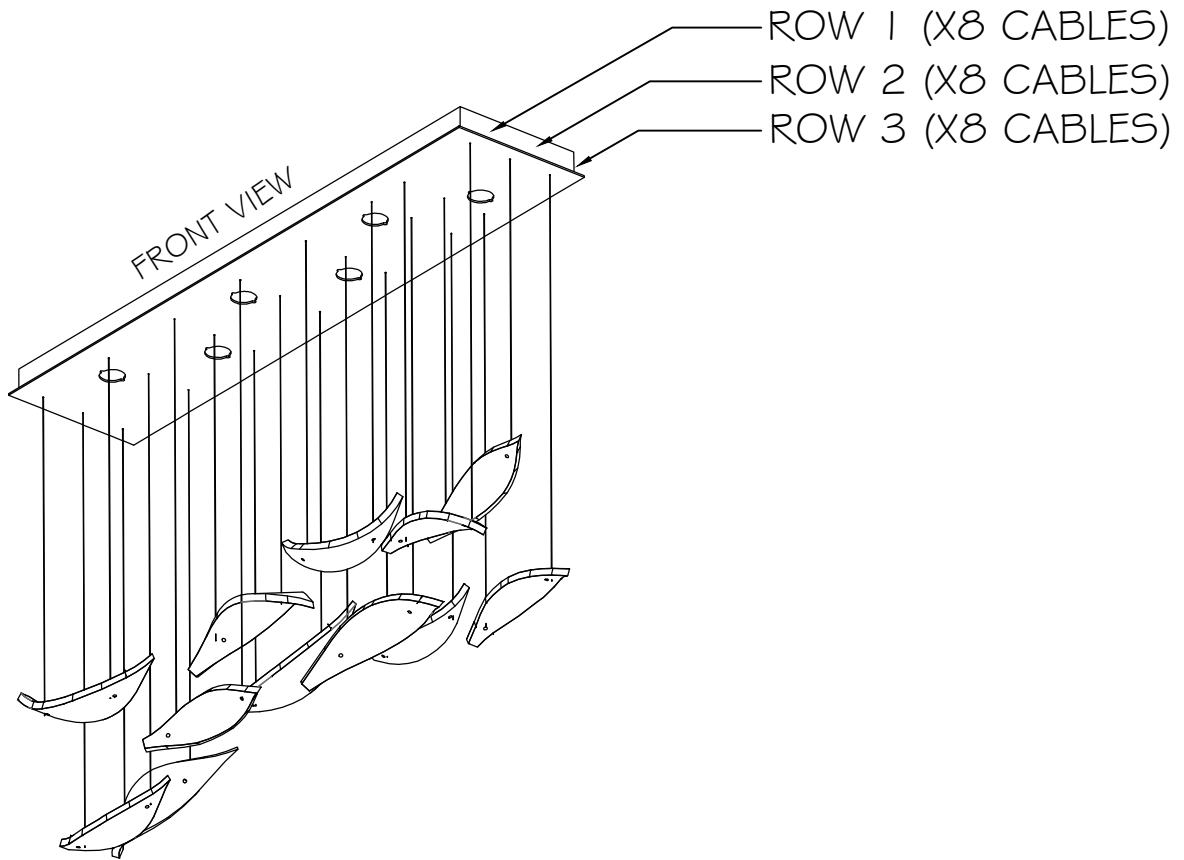

STYLE(S) #: 895140-111 -211 -121 -221



This drawing, specifications and the product depicted are the exclusive property of Fine Art Handcrafted Lighting®. In compliance with US copyright and patent requirements, notice is hereby given that this document and the product depicted shall not be copied, altered or used in any manner without the expressed written consent of Fine Art Handcrafted Lighting®.

[www.finearthl.com](http://www.finearthl.com)

Tel: (305) 821-3850  
FINE ART LAMPS®

Fax: (305) 513-5736

INSTRUCTION #:

00791410

SHEET

1 / 5

# INSTRUCTIONS for PLUME GLASS OPTIONS

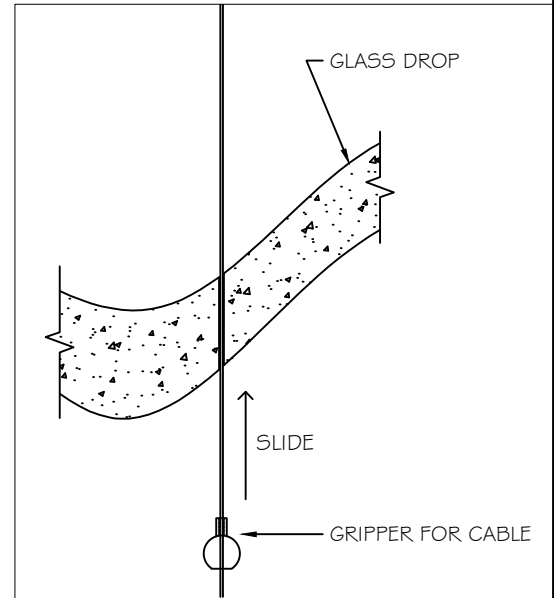
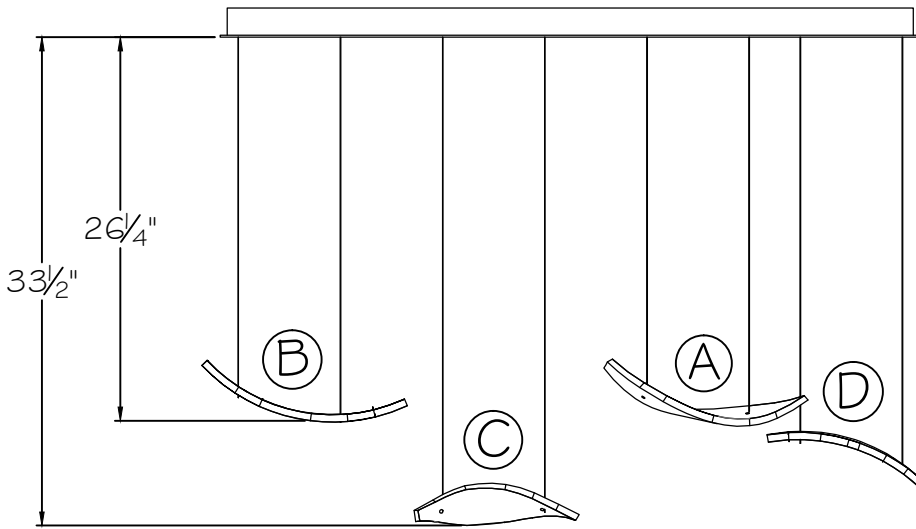
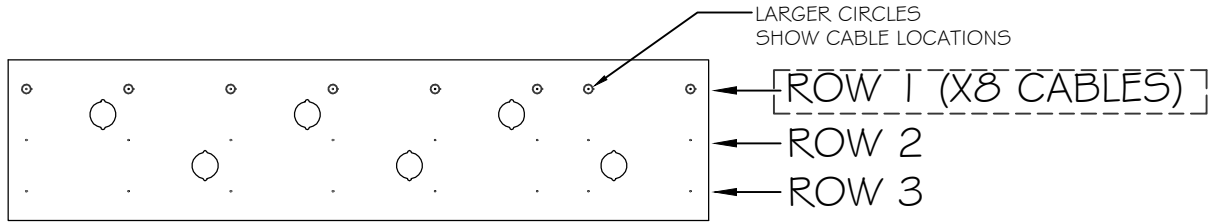

## ROW 1

GLASS TYPE	QUANTITY
TYPE A	1
TYPE B	1
TYPE C	1
TYPE D	1

- FIRST ROW OF GLASSES TO BE INSTALLED IS ROW 1.
- GATHER ALL OTHER CABLES TO THE SIDE TO EASILY ACCESS LAYER TO BE WORKED ON
- LETTERS IN CIRCLES ON DIAGRAM INDICATE GLASS TYPE THAT CORRESPONDS TO STICKERS ON GLASS
- START SLIDING GLASSES UP INTO POSITION AS SHOWN ON FRONT VIEW, STARTING FROM TOP TO BOTTOM
- SLIDE GRIPPER UP TO HOLD POSITION OF GLASS
- NOTE: MULTIPLE GLASSES MAY USE THE SAME CABLES

STYLE(S) #: 895140-111 -211 -121 -221



This drawing, specifications and the product depicted are the exclusive property of Fine Art Handcrafted Lighting®. In compliance with US copyright and patent requirements, notice is hereby given that this document and the product depicted shall not be copied, altered or used in any manner without the expressed written consent of Fine Art Handcrafted Lighting®.

www.finearthl.com

Tel:(305) 821-3850  
FINE ART LAMPS®

Fax:(305) 513-5736

INSTRUCTION #:

00791410

SHEET

2 / 5

# INSTRUCTIONS for PLUME GLASS OPTIONS

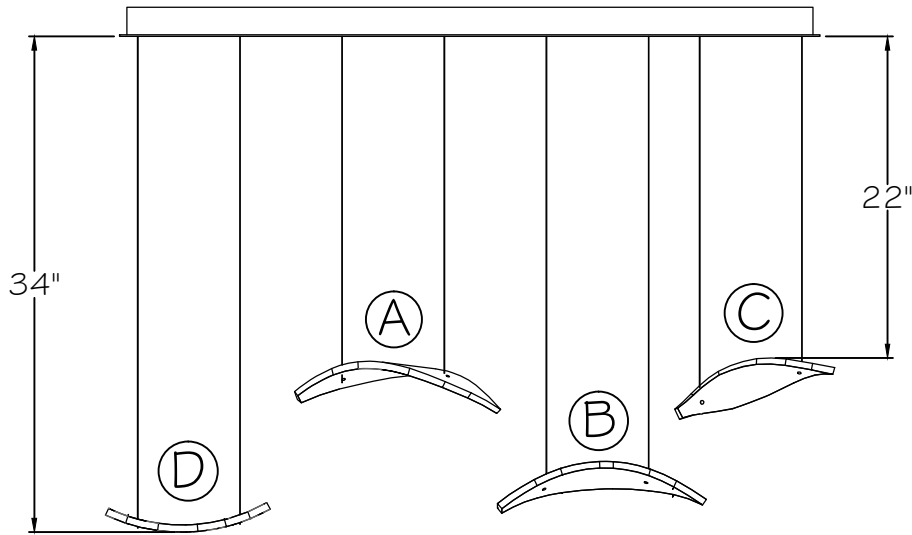
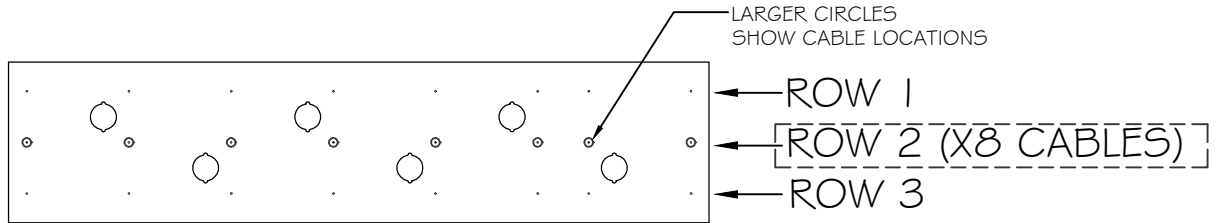

## ROW 2

GLASS TYPE	QUANTITY
TYPE A	1
TYPE B	1
TYPE C	1
TYPE D	1

- NEXT ROW OF GLASSES TO BE INSTALLED IS ROW 2.
- START SLIDING GLASSES UP INTO POSITION AS SHOWN ON FRONT VIEW, STARTING FROM TOP TO BOTTOM
- SLIDE GRIPPER UP TO HOLD POSITION OF GLASS
- NOTE: MULTIPLE GLASSES MAY USE THE SAME CABLES

STYLE(S) #: 895140-111 -211 -121 -221



This drawing, specifications and the product depicted are the exclusive property of Fine Art Handcrafted Lighting®. In compliance with US copyright and patent requirements, notice is hereby given that this document and the product depicted shall not be copied, altered or used in any manner without the expressed written consent of Fine Art Handcrafted Lighting®.

www.finearthl.com

Tel:(305) 821-3850  
FINE ART LAMPS®

Fax:(305) 513-5736

INSTRUCTION #:

00791410

SHEET

3 / 5

# INSTRUCTIONS for PLUME GLASS OPTIONS

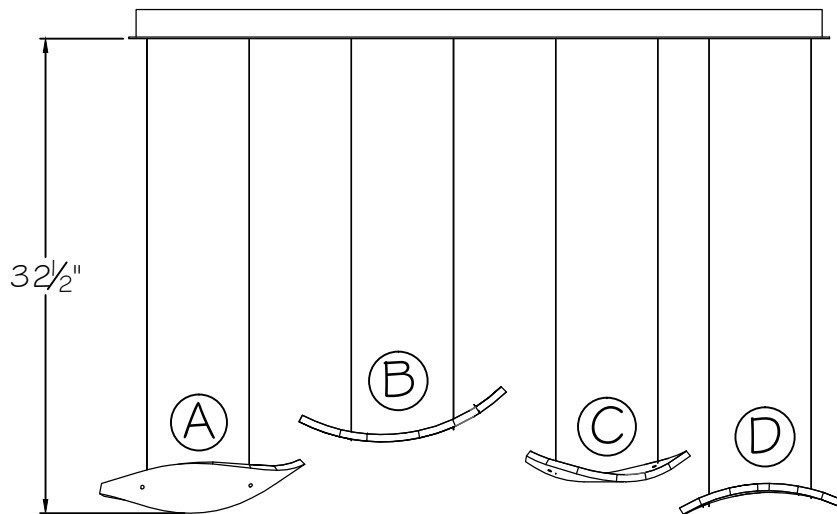
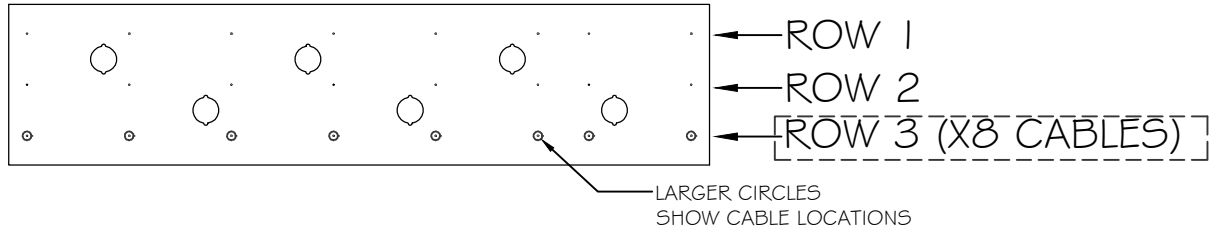

ROW 3	
GLASS TYPE	QUANTITY
TYPE A	1
TYPE B	1
TYPE C	1
TYPE D	1

- NEXT ROW OF GLASSES TO BE INSTALLED IS ROW 3.
- START SLIDING GLASSES UP INTO POSITION AS SHOWN ON FRONT VIEW, STARTING FROM TOP TO BOTTOM
- SLIDE GRIPPER UP TO HOLD POSITION OF GLASS
- NOTE: MULTIPLE GLASSES MAY USE THE SAME CABLES

STYLE(S) #: 895140-111 -211 -121 -221



This drawing, specifications and the product depicted are the exclusive property of Fine Art Handcrafted Lighting®. In compliance with US copyright and patent requirements, notice is hereby given that this document and the product depicted shall not be copied, altered or used in any manner without the expressed written consent of Fine Art Handcrafted Lighting®.

www.finearthl.com

Tel:(305) 821-3850  
FINE ART LAMPS®

Fax:(305) 513-5736

INSTRUCTION #:

00791410

SHEET

4 / 5

# INSTRUCTIONS for PLUME GLASS OPTIONS

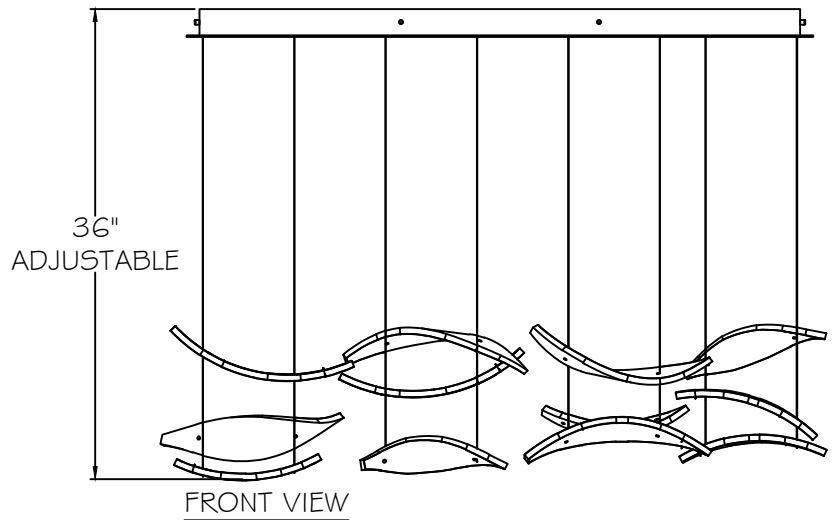
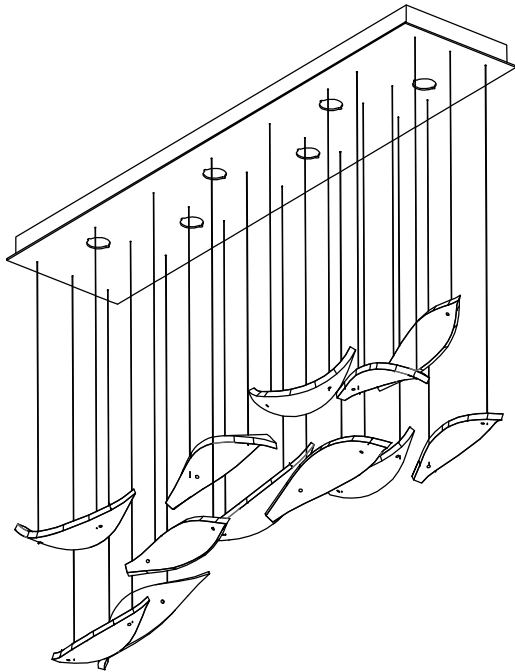

- ONCE ALL GLASSES ARE INSTALLED AND FINAL GLASS POSITION IS ACHIEVED, ENSURE TO CUT EXCESS CABLES UP TO HARDWARE OF LOWEST GLASSES

STYLE(S) #: 895140-111 -211 -121 -221



This drawing, specifications and the product depicted are the exclusive property of Fine Art Handcrafted Lighting®. In compliance with US copyright and patent requirements, notice is hereby given that this document and the product depicted shall not be copied, altered or used in any manner without the expressed written consent of Fine Art Handcrafted Lighting®.

[www.finearthl.com](http://www.finearthl.com)

Tel:(305) 821-3850  
FINE ART LAMPS®

Fax:(305) 513-5736

INSTRUCTION #:

00791410

SHEET

5 / 5

# INSTRUCTIONS for SPIRES GLASS OPTIONS

**NOTE: ORIENTATION OF CANOPY IS CRITICAL TO GLASS DROP DESIGN**

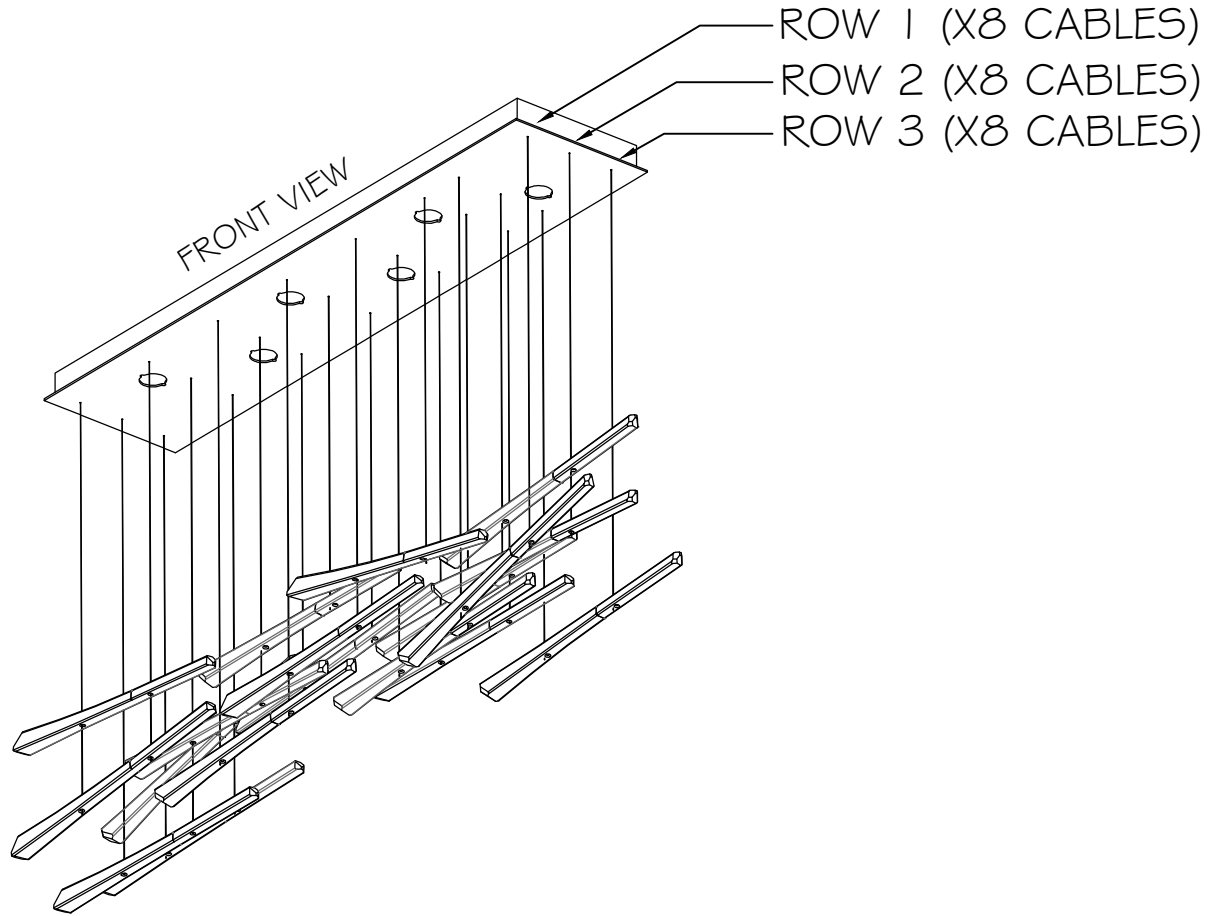

STYLE(S) #: 895140-131 -231 -141 -241 -151 -251



This drawing, specifications and the product depicted are the exclusive property of Fine Art Handcrafted Lighting®. In compliance with US copyright and patent requirements, notice is hereby given that this document and the product depicted shall not be copied, altered or used in any manner without the expressed written consent of Fine Art Handcrafted Lighting®.

[www.finearthl.com](http://www.finearthl.com)

Tel: (305) 821-3850

Fax: (305) 513-5736

FINE ART LAMPS®

INSTRUCTION #:

00791411

SHEET

1 / 5



# INSTRUCTIONS for SPIRES GLASS OPTIONS

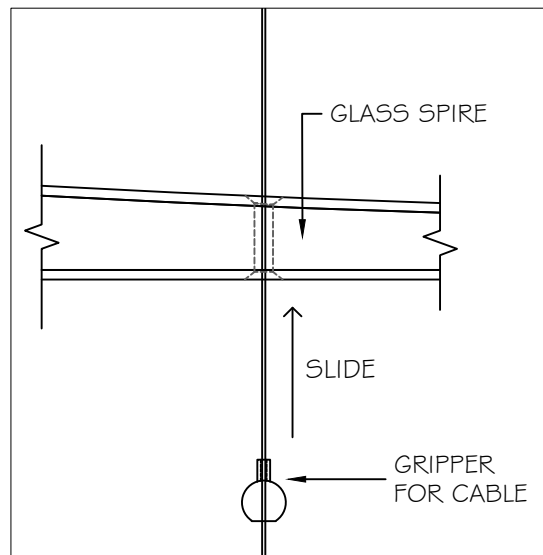
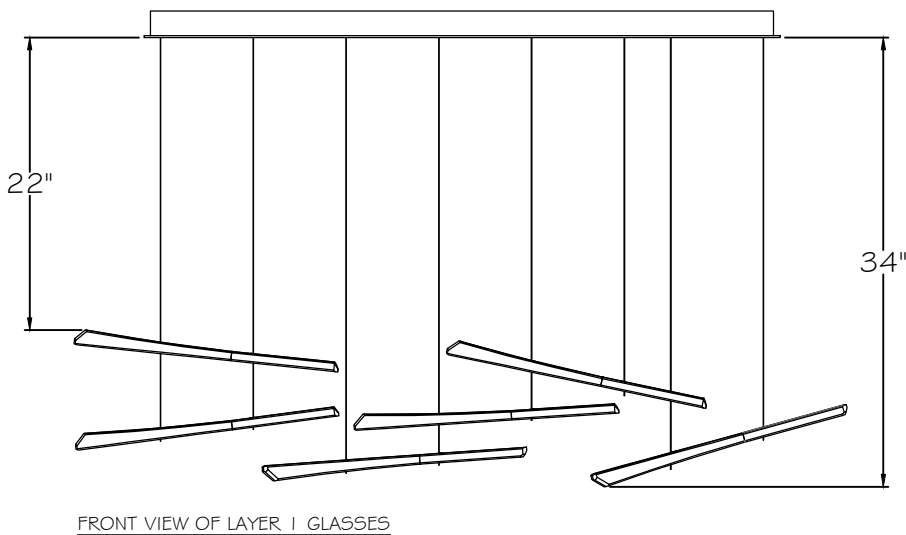
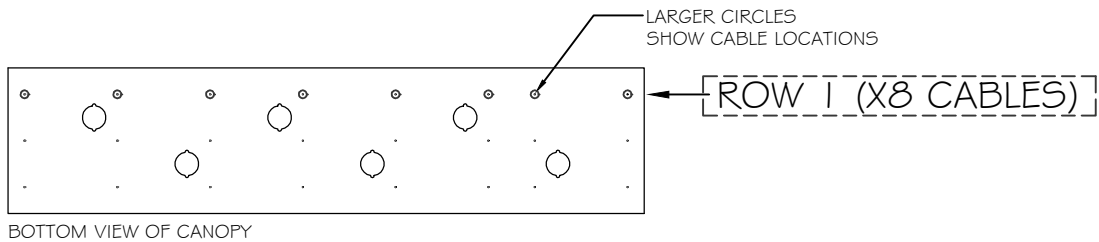

- FIRST ROW OF GLASSES TO BE INSTALLED IS ROW 1.
- GATHER ALL OTHER CABLES TO THE SIDE TO EASILY ACCESS LAYER TO BE WORKED ON
- START SLIDING GLASSES UP INTO POSITION AS SHOWN ON FRONT VIEW, STARTING FROM TOP TO BOTTOM
- SLIDE GRIPPER UP TO HOLD POSITION OF GLASS
- NOTE: MULTIPLE GLASSES MAY USE THE SAME CABLES

STYLE(S) #: 895140-131 -231 -141 -241 -151 -251



This drawing, specifications and the product depicted are the exclusive property of Fine Art Handcrafted Lighting®. In compliance with US copyright and patent requirements, notice is hereby given that this document and the product depicted shall not be copied, altered or used in any manner without the expressed written consent of Fine Art Handcrafted Lighting®.

www.finearthl.com

Tel:(305) 821-3850  
FINE ART LAMPS®

Fax:(305) 513-5736

INSTRUCTION #:

00791411

SHEET

2 / 5

# INSTRUCTIONS for SPIRES GLASS OPTIONS

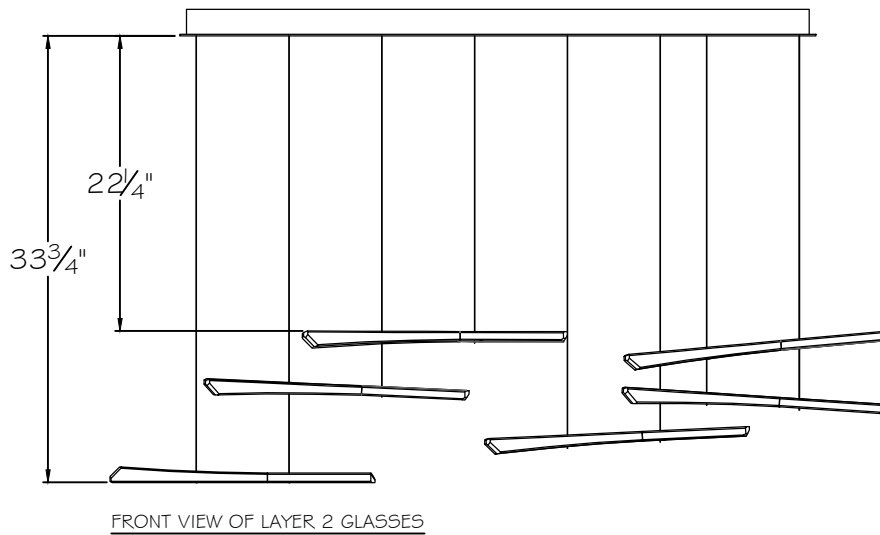
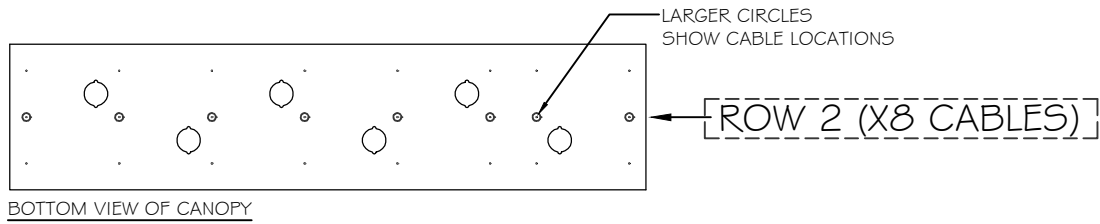

- NEXT ROW OF GLASSES TO BE INSTALLED IS ROW 2.
- START SLIDING GLASSES UP INTO POSITION AS SHOWN ON FRONT VIEW, STARTING FROM TOP TO BOTTOM
- SLIDE GRIPPER UP TO HOLD POSITION OF GLASS
- NOTE: MULTIPLE GLASSES MAY USE THE SAME CABLES

STYLE(S) #: 895140-131 -231 -141 -241 -151 -251



This drawing, specifications and the product depicted are the exclusive property of Fine Art Handcrafted Lighting®. In compliance with US copyright and patent requirements, notice is hereby given that this document and the product depicted shall not be copied, altered or used in any manner without the expressed written consent of Fine Art Handcrafted Lighting®.

www.finearthl.com

Tel:(305) 821-3850  
FINE ART LAMPS®

Fax:(305) 513-5736

INSTRUCTION #:

00791411

SHEET

3 / 5

# INSTRUCTIONS for SPIRES GLASS OPTIONS

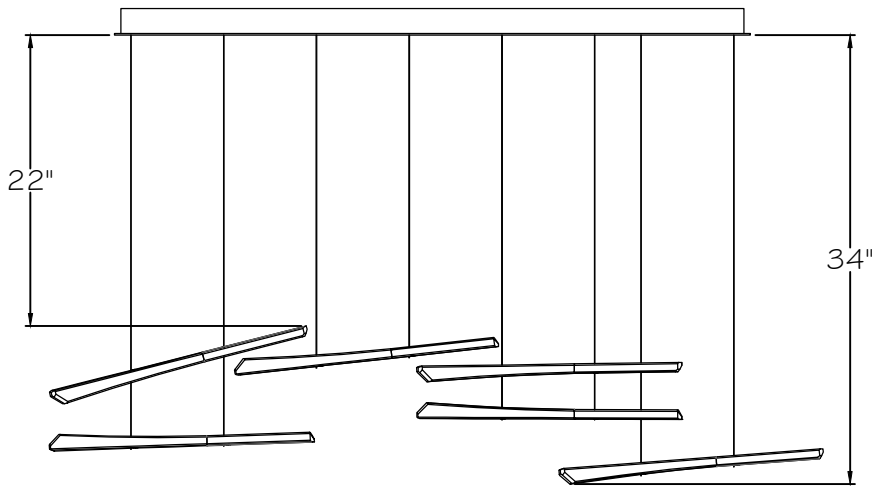
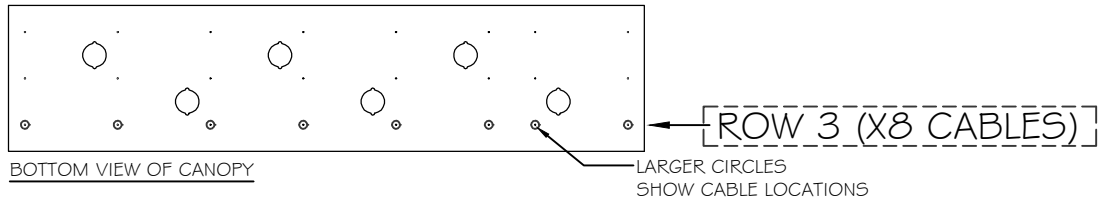

FRONT VIEW OF LAYER 3 GLASSES

- NEXT ROW OF GLASSES TO BE INSTALLED IS ROW 3.
- START SLIDING GLASSES UP INTO POSITION AS SHOWN ON FRONT VIEW, STARTING FROM TOP TO BOTTOM
- SLIDE GRIPPER UP TO HOLD POSITION OF GLASS
- NOTE: MULTIPLE GLASSES MAY USE THE SAME CABLES

STYLE(S) #: 895140-131 -231 -141 -241 -151 -251



This drawing, specifications and the product depicted are the exclusive property of Fine Art Handcrafted Lighting®. In compliance with US copyright and patent requirements, notice is hereby given that this document and the product depicted shall not be copied, altered or used in any manner without the expressed written consent of Fine Art Handcrafted Lighting®.

www.finearthl.com

Tel:(305) 821-3850  
FINE ART LAMPS®

Fax:(305) 513-5736

INSTRUCTION #:

00791411

SHEET

4 / 5

# INSTRUCTIONS for SPIRES GLASS OPTIONS

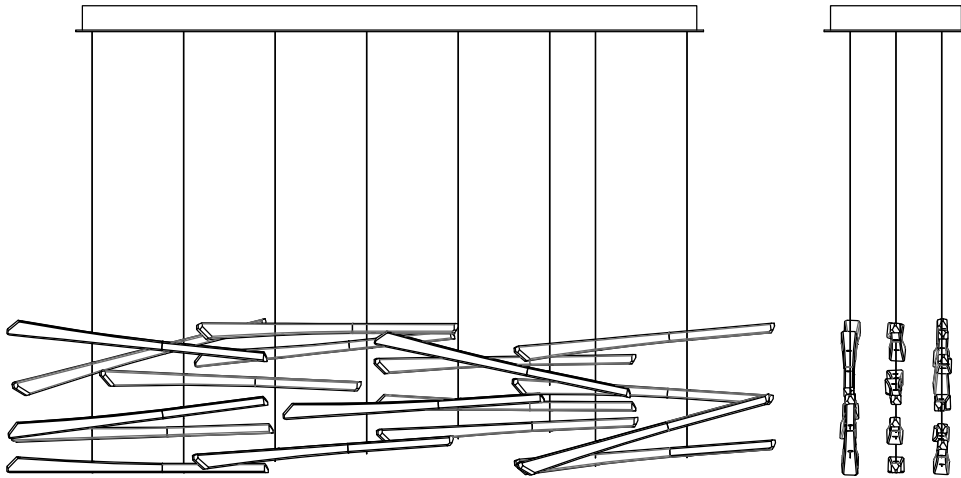

- ONCE ALL GLASSES ARE INSTALLED AND FINAL GLASS POSITION IS ACHIEVED, ENSURE TO CUT EXCESS CABLES UP TO HARDWARE OF LOWEST GLASSES. REFERENCE INSTALLATION INSTRUCTION.

STYLE(S) #: 895140-131 -231 -141 -241 -151 -251



This drawing, specifications and the product depicted are the exclusive property of Fine Art Handcrafted Lighting®. In compliance with US copyright and patent requirements, notice is hereby given that this document and the product depicted shall not be copied, altered or used in any manner without the expressed written consent of Fine Art Handcrafted Lighting®.

[www.finearthl.com](http://www.finearthl.com)

Tel:(305) 821-3850  
FINE ART LAMPS®

Fax:(305) 513-5736

INSTRUCTION #:

00791411

SHEET

5 / 5

NOTE:ORIENTATION OF CANOPY IS CRITICAL TO GLASS DROP DESIGN

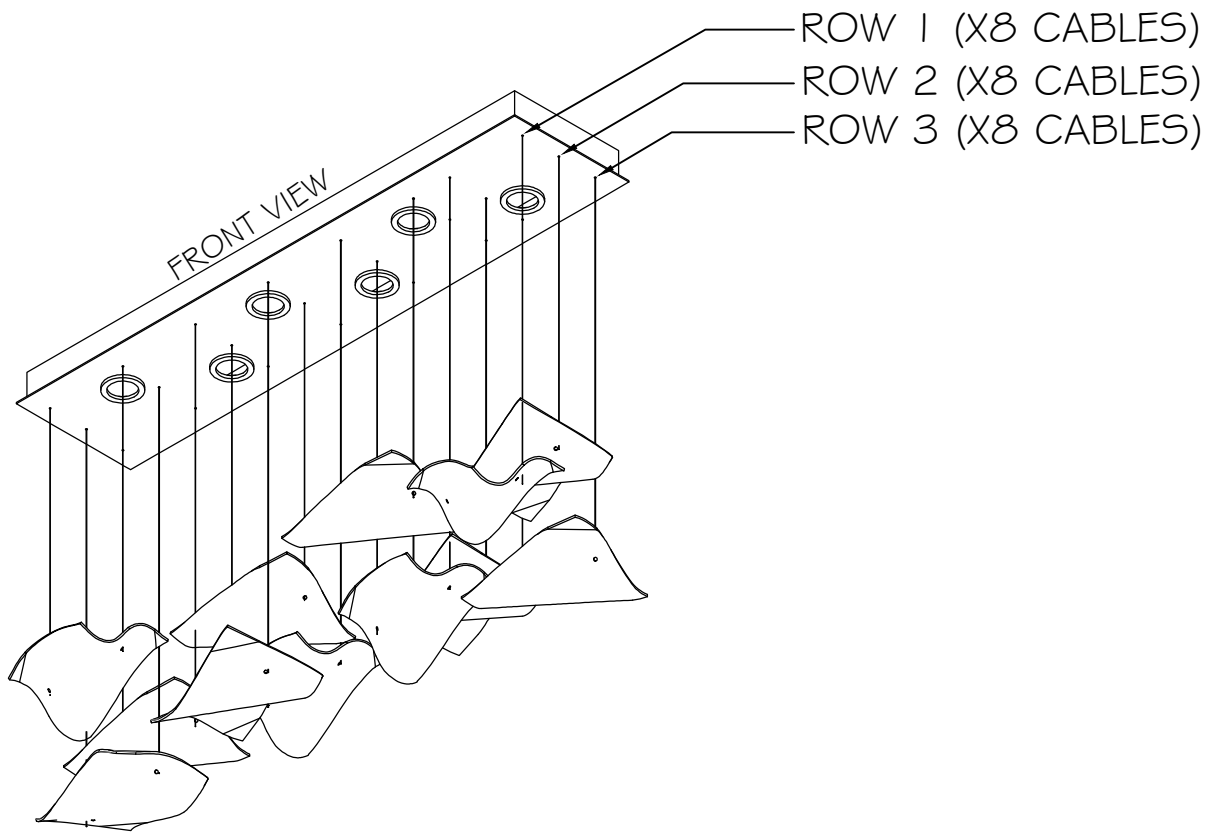

STYLE(S) #: 895140-161 -261 -171 -271



This drawing, specifications and the product depicted are the exclusive property of Fine Art Handcrafted Lighting®. In compliance with US copyright and patent requirements, notice is hereby given that this document and the product depicted shall not be copied, altered or used in any manner without the expressed written consent of Fine Art Handcrafted Lighting®.

[www.finearthl.com](http://www.finearthl.com)

Tel:(305) 821-3850  
FINE ART LAMPS®

Fax:(305) 513-5736

INSTRUCTION #:

00791495

SHEET

1 / 5

# INSTRUCTIONS for PAGES GLASS OPTIONS

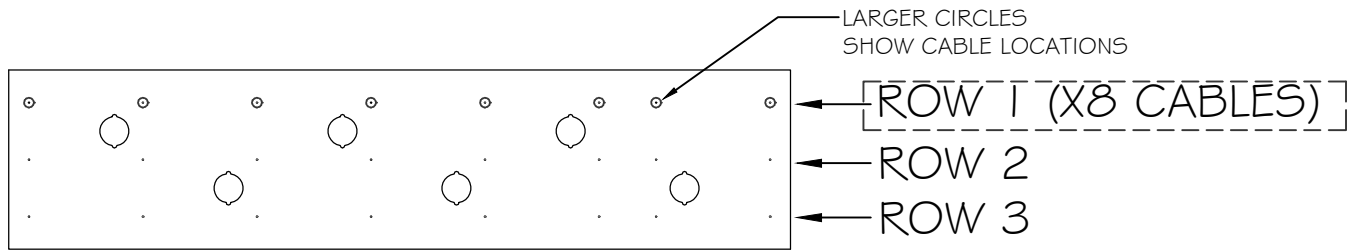

BOTTOM VIEW OF CANOPY

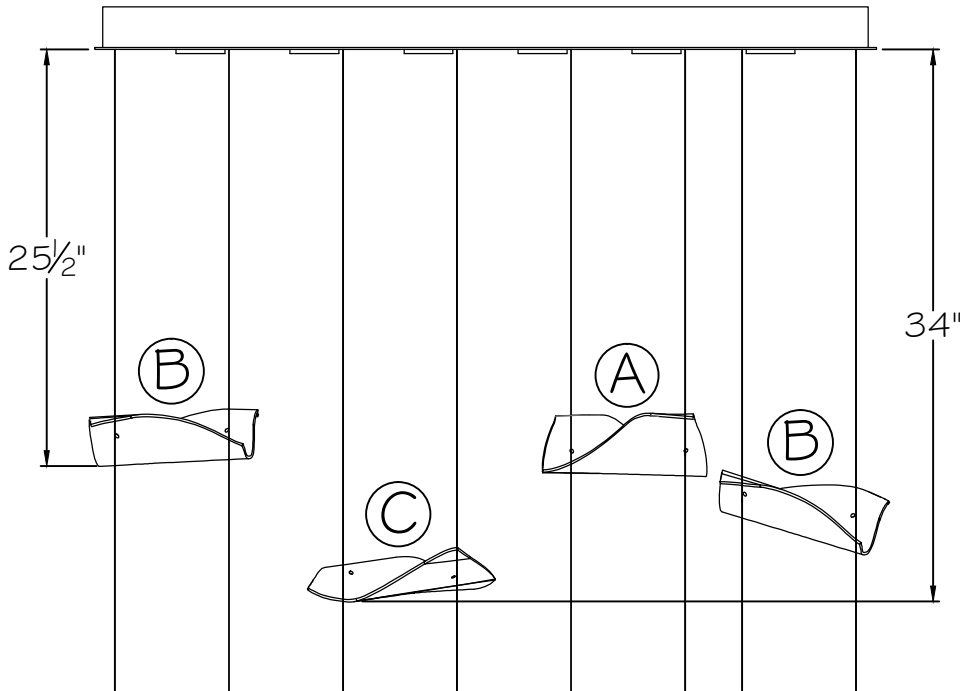

FRONT VIEW OF LAYER 1 GLASSES

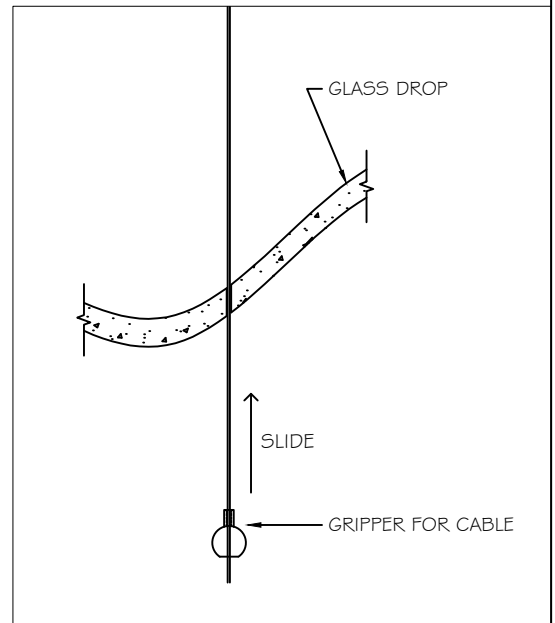

## ROW 1

GLASS TYPE	QUANTITY
TYPE A	1
TYPE B	2
TYPE C	1

- FIRST ROW OF GLASSES TO BE INSTALLED IS ROW 1.
- GATHER ALL OTHER CABLES TO THE SIDE TO EASILY ACCESS LAYER TO BE WORKED ON
- LETTERS IN CIRCLES ON DIAGRAM INDICATE GLASS TYPE THAT CORRESPONDS TO STICKERS ON GLASS
- START SLIDING GLASSES UP INTO POSITION AS SHOWN ON FRONT VIEW, STARTING FROM TOP TO BOTTOM
- SLIDE GRIPPER UP TO HOLD POSITION OF GLASS
- NOTE: MULTIPLE GLASSES MAY USE THE SAME CABLES

STYLE(S) #: 895140-161 -261 -171 -271



This drawing, specifications and the product depicted are the exclusive property of Fine Art Handcrafted Lighting®. In compliance with US copyright and patent requirements, notice is hereby given that this document and the product depicted shall not be copied, altered or used in any manner without the expressed written consent of Fine Art Handcrafted Lighting®.

www.finearthl.com

Tel:(305) 821-3850  
FINE ART LAMPS®

Fax:(305) 513-5736

INSTRUCTION #:

00791495

SHEET

2 / 5

# INSTRUCTIONS for PAGES GLASS OPTIONS

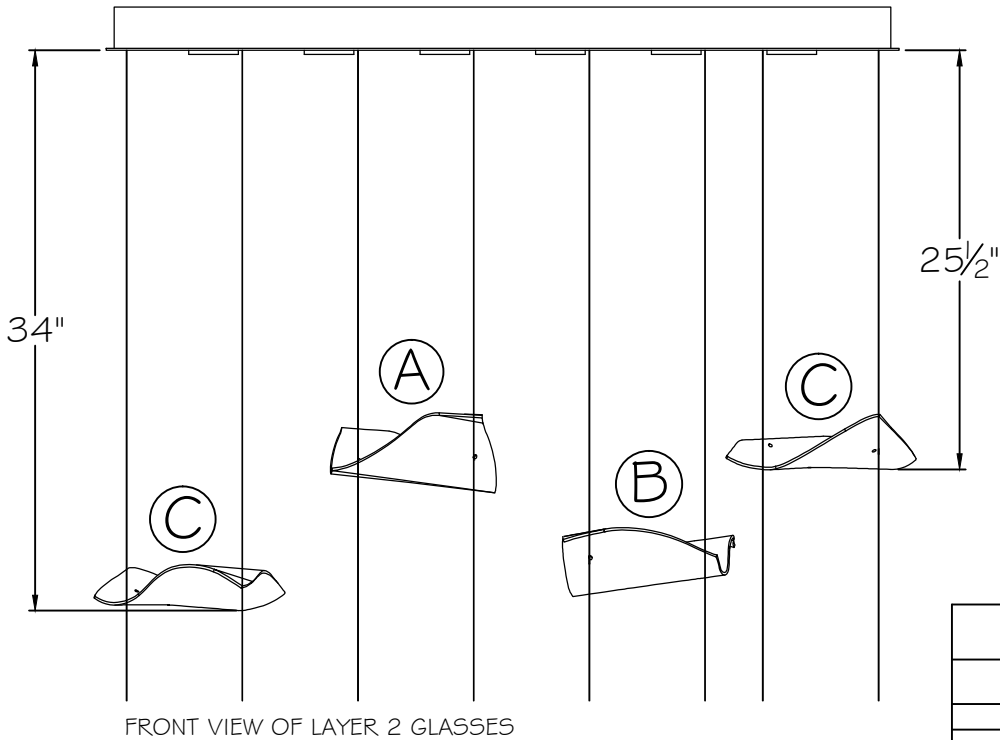
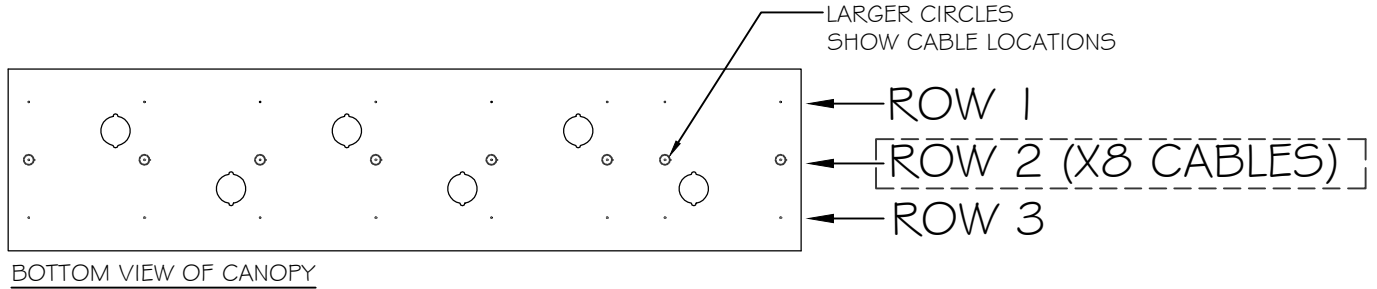

ROW 2	
GLASS TYPE	QUANTITY
TYPE A	1
TYPE B	1
TYPE C	2

- NEXT ROW OF GLASSES TO BE INSTALLED IS ROW 2.
- START SLIDING GLASSES UP INTO POSITION AS SHOWN ON FRONT VIEW, STARTING FROM TOP TO BOTTOM
- SLIDE GRIPPER UP TO HOLD POSITION OF GLASS
- NOTE: MULTIPLE GLASSES MAY USE THE SAME CABLES

STYLE(S) #: 895140-161 -261 -171 -271



This drawing, specifications and the product depicted are the exclusive property of Fine Art Handcrafted Lighting®. In compliance with US copyright and patent requirements, notice is hereby given that this document and the product depicted shall not be copied, altered or used in any manner without the expressed written consent of Fine Art Handcrafted Lighting®.

www.finearthl.com

Tel:(305) 821-3850  
FINE ART LAMPS®

Fax:(305) 513-5736

INSTRUCTION #:

00791495

SHEET

3 / 5

# INSTRUCTIONS for PAGES GLASS OPTIONS

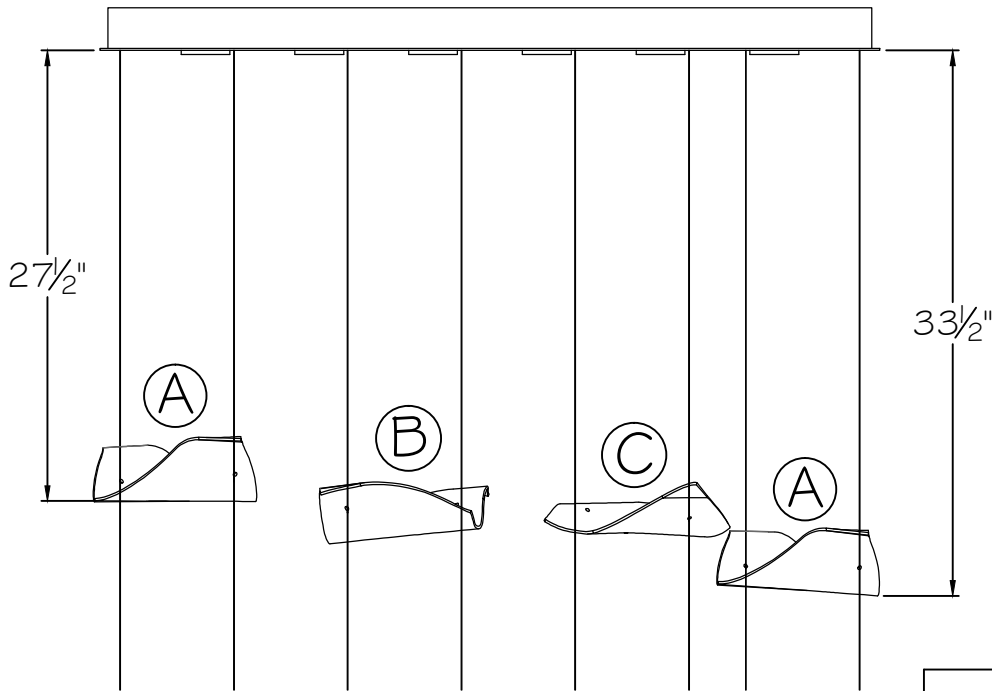
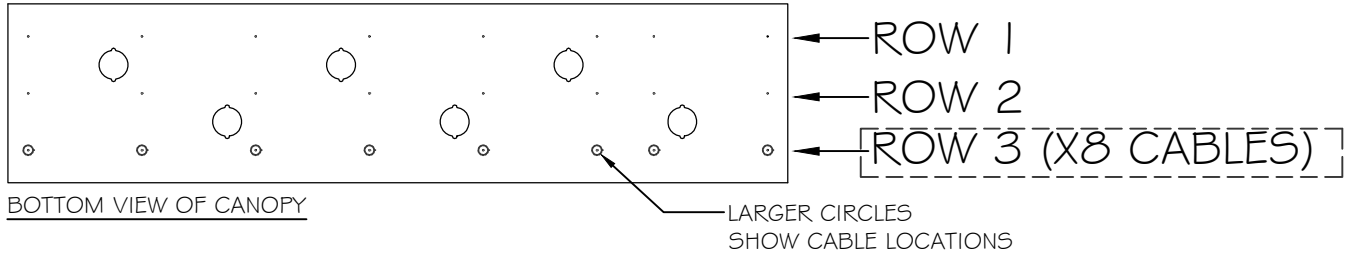

FRONT VIEW OF LAYER 3 GLASSES

ROW 3	
GLASS TYPE	QUANTITY
TYPE A	2
TYPE B	1
TYPE C	1

- NEXT ROW OF GLASSES TO BE INSTALLED IS ROW 3.
- START SLIDING GLASSES UP INTO POSITION AS SHOWN ON FRONT VIEW, STARTING FROM TOP TO BOTTOM
- SLIDE GRIPPER UP TO HOLD POSITION OF GLASS
- NOTE: MULTIPLE GLASSES MAY USE THE SAME CABLES

STYLE(S) #: 895140-161 -261 -171 -271



This drawing, specifications and the product depicted are the exclusive property of Fine Art Handcrafted Lighting®. In compliance with US copyright and patent requirements, notice is hereby given that this document and the product depicted shall not be copied, altered or used in any manner without the expressed written consent of Fine Art Handcrafted Lighting®.

www.finearthl.com

Tel:(305) 821-3850  
 FINE ART LAMPS®

Fax:(305) 513-5736

INSTRUCTION #:

00791495

SHEET

4 / 5



# INSTRUCTIONS for PAGES GLASS OPTIONS

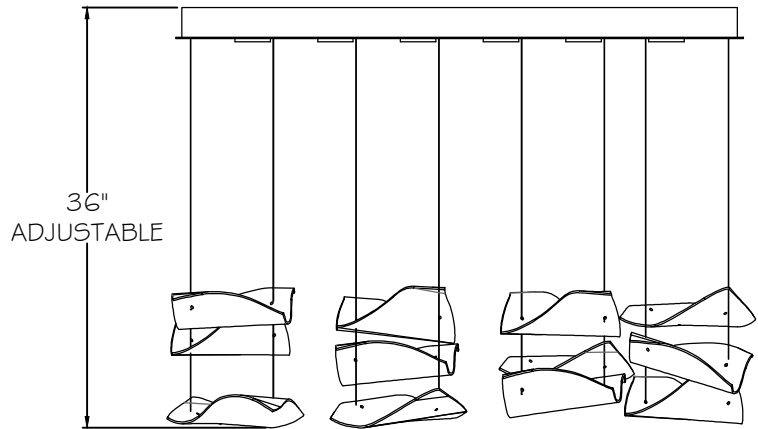
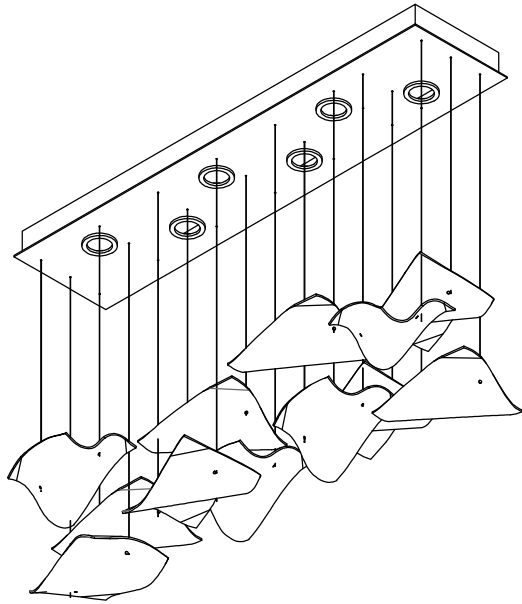

- ONCE ALL GLASSES ARE INSTALLED AND FINAL GLASS POSITION IS ACHIEVED, ENSURE TO CUT EXCESS CABLES UP TO HARDWARE OF LOWEST GLASSES

STYLE(S) #: 895140-161 -261 -171 -271



This drawing, specifications and the product depicted are the exclusive property of Fine Art Handcrafted Lighting®. In compliance with US copyright and patent requirements, notice is hereby given that this document and the product depicted shall not be copied, altered or used in any manner without the expressed written consent of Fine Art Handcrafted Lighting®.

[www.finearthl.com](http://www.finearthl.com)

Tel:(305) 821-3850  
FINE ART LAMPS®

Fax:(305) 513-5736

INSTRUCTION #:

00791495

SHEET

5 / 5