

# Hot Foot Corded Foot Pedal Guide



Guide



# SAFETY

**WARNING!** Read and understand all safety messages in this and the welding power source owner's manual.



ELECTRIC SHOCK can kill.



SMOKE, FUMES AND GASES can be hazardous to your health.



WELDING can cause fire and explosion.



ARC RAYS can burn eyes and skin.

# DIMENSIONS & WEIGHT

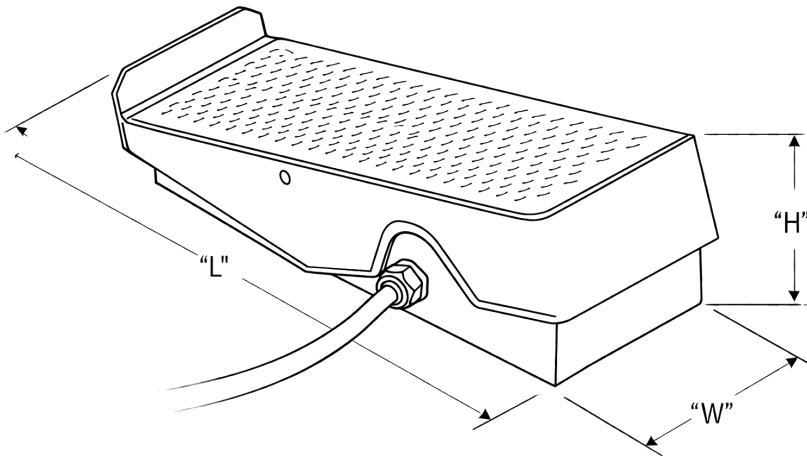

"H"eight = 4.125  
"W"idth = 4.500  
"L"ength = 12.000  
-----  
Weight = 8.5 lbs.

# INSIDE OF FOOT PEDAL

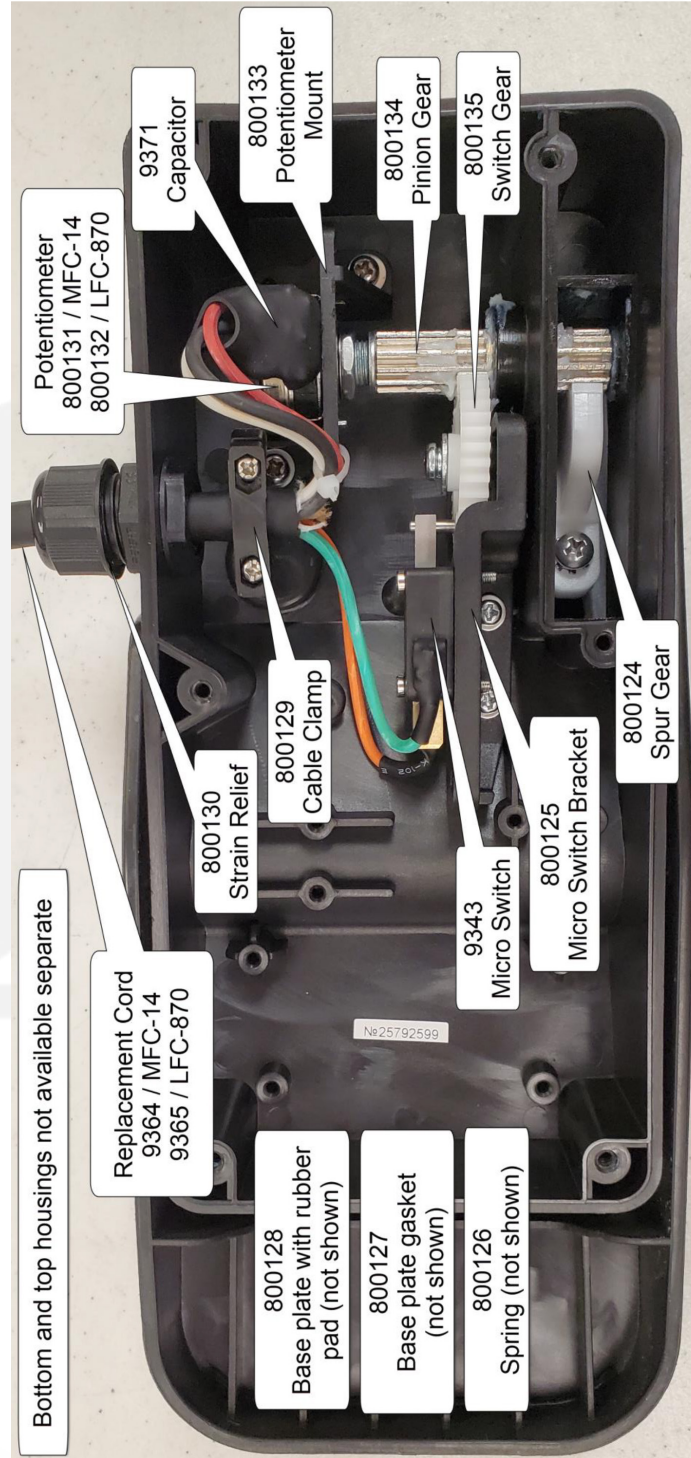

# FOOT PEDAL DIAGRAM

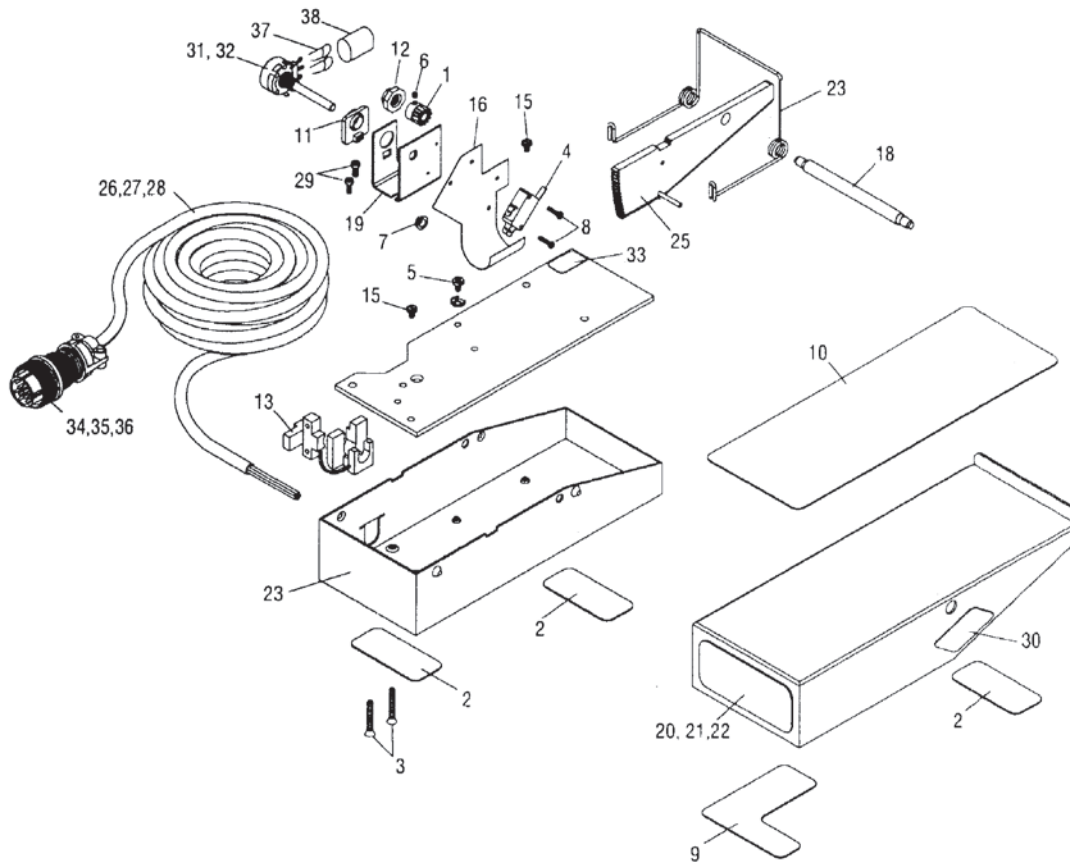

**A-LFC-870:** LINCOLN ELECTRIC

**A-MFC-14:** Miller

**A-EFC-14:** ESAB

# FOOT PEDAL PARTS LIST

NO	P/N	DESCRIPTION	MFC-14	LFC-870	EFC-14
1	9340	Pinion gear	1	1	1
2	9341	Rubber base pad	3	3	3
3	9342	#8-10 x 1.250 Screw	2	2	2
4	9343	Micro switch	1	1	1
5	9344	#8-32 x .281 Screw	1	1	1
6	9345	#6-32 x .1875 Screw	1	1	1
7	9346	Nylon bearing	1	1	1
8	9347	#4-40 x .500 Screw	2	2	2
9	9348	Rubber bumper pad	1	1	1
10	9349	Rubber foot pad	1	1	1
11	9350	Mount bracket	1	1	1
12	9351	Spacer nut	1	1	1
13	9352	Cable clamp	1	1	1
14	9353	Top cover	1	1	1
15	9354	#8-32 x .250 Screw	2	2	2
16	9355	Insulation	1	1	1
17	9356	Inner plate	1	1	1
18	9357	Pivot rod asebly	1	1	1
19	9358	Potentiometer bracket	1	1	1

NO	P/N	DESCRIPTION	MFC-14	LFC-870	EFC-14
20	9359	Arc-Zone Logo	1	1	1
21	9360	Arc-Zone Logo	3	3	3
22	9353	Arc-Zone Logo	2	2	2
23	9361	Spring	1	1	1
24	9362	Base	1	1	1
25	9263	Spur gear level	1	1	1
26	9364	25' cord set with 14 pin plug	1	1	1
27	9365	25' cord set with 6 pin plug	2	2	2
28	9354	25' cord set with 14 pin plug	1	1	1
29	9366	#8-32 x .375 Screw	1	1	1
30	9367	Warning Label	1	1	1
31	9368	Potentiometer 10K, 1T, 2W	1	1	1
32	9369	Potentiometer 1K, 1T, 2W	1	1	1
33	9370	Warning Label	1	1	1
34	9317	Miller 14 pin plug only	2	2	2
35	9319	Lincoln 6 pin plug only	1	1	1
36	S12020-32	ESAB® 14 pin plug only	1	1	1
37	9371	Capacitator 4700VF,3KV	1	1	1
38	9372	1-5/16 x 1-3/4 Heat shrink tubing	1	1	1

# WIRING DIAGRAM

## MFC-14 WIRING DIAGRAM

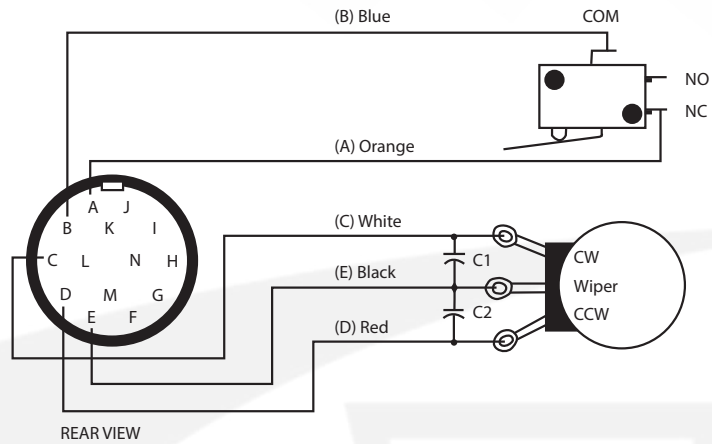

## EFC-14 WIRING DIAGRAM

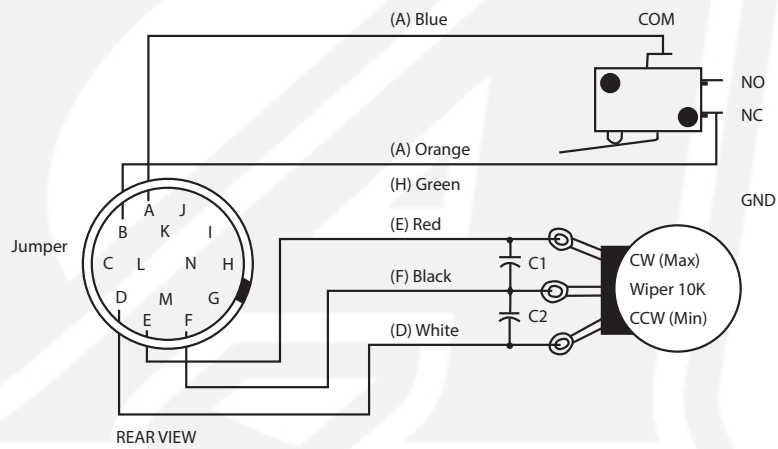

## LFC-870 WIRING DIAGRAM

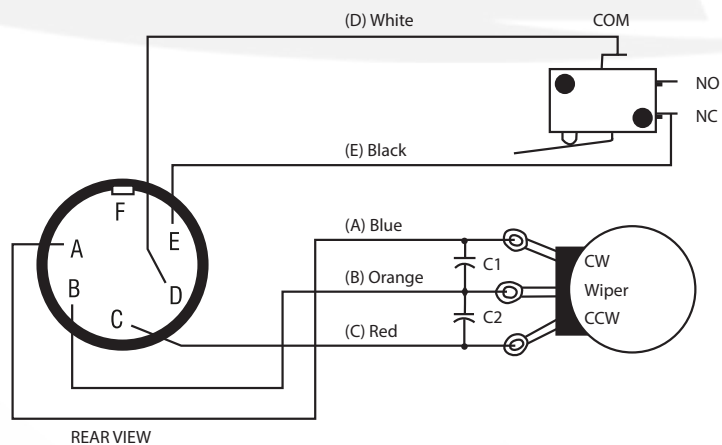

Arc-Zone.com, Inc.