



Order Online: WWW.RENNLINE.COM

EM Sales@rennline.com

PH 802.893.7366

FX 802-893-7311

Driven to improve excellence.

## Truss Mount 2 Point (Dual) Strut Brace

911/912/930

### READ BEFORE INSTALLATION

The use of any Rennline product is the sole responsibility of the end user. Rennline Inc. accepts no responsibility for warranty voids or damage resulting from the use of these products. Do to the varying location of wiring harnesses and other components, carefully inspect any area prior to drilling. All Rennline products are intended for off road use and should be installed by a qualified automotive technician.

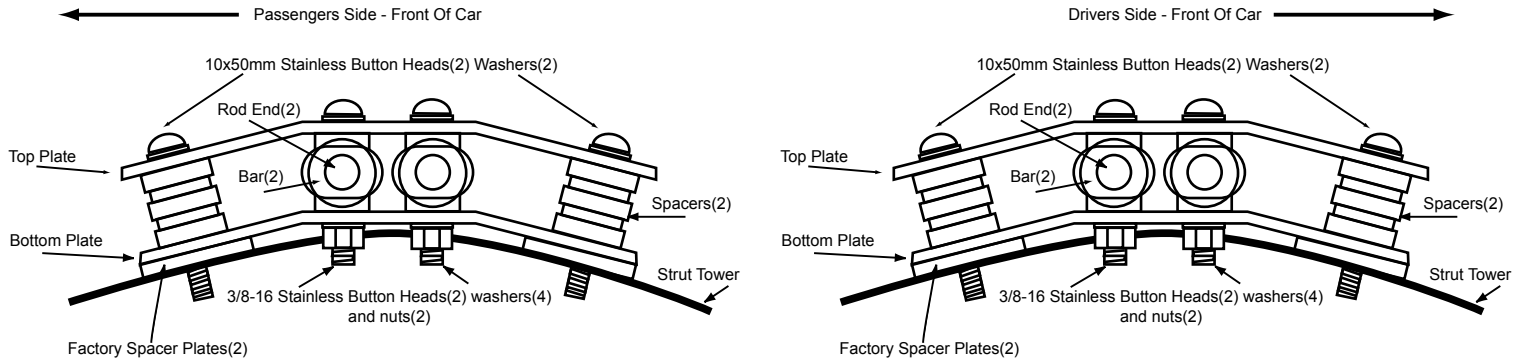

Check to make sure that you have all parts listed prior to installation. If anything is missing contact us immediately.

### Parts List

- (1) 29.75" Bar - SB91
- (1) 29.75" Bar - SB93
- (1) Left Bracket set(1 upper 1 lower)
- (1) Right Bracket set(1 upper 1 lower)
- (4) M10x50X1.5 S/S Button Cap Screw - MC92095A424
- (12) .375 S/S Washer - MC98017A199
- (6) .411ID X.910OD X.60 6061 Spacers - SPC
- (1) 1/2-20 Rod end - CVEM8
- (1) 1/2-20 Rod end - CVEM8L
- (1) 1/2-20 Jam Nut - MC94846A525
- (1) 1/2-20 Jam Nut - MC99612A136
- (4) 3/8-16 S/S Nut - MC91845A031
- (4) 3/8-16 X1.5" S/S Button Cap Screw - MC92949A628
- (2) 3/8 Bronze Bushings .5 OD - MC6391K174



Install as shown above. Note: Drivers side top bracket is marked with a red dot on the top side. Keep all bolts finger tight until installation is complete.

### BARS

Install rod ends into each end of cross bars. All left handed threads are marked in red.

Tighten all components except for the lock nuts on each end of the cross bars.

Cross bar length is adjusted by rotating center bar while end joints stay stationary.

Adjust Cross bars to the desired prestress and then tighten lock nuts.

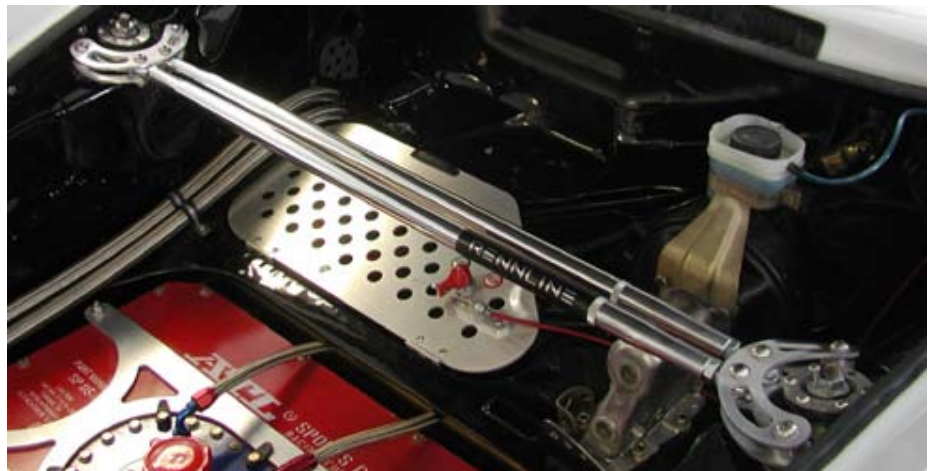

SB- 809193