

ITEM NO.	QTY.	PART NO.	DESCRIPTION
1	1	EXXX	TOW HOOK BASE SCREW
2	1	92949AXXX	1/2"-13 ROUND HD SCREW, S/S
3	1	SPACER	TOW HOOK SCREW SHAFT SPACER
*4	1	E19_A	LOOP, FOLDING TOW HOOK, REV B
*5	1	E19_B	EYE MOUNT, TOW HOOK, FOLDING
*6	2	90145A583	5/16" DIA X 1.00" LG DOWEL PIN, S/S
*7	1	92991A824	10-32 X 3/16" LG SET SCREW, BRASS, CUP TIP (loctite)
8	1	95495K121	RUBBER DOME BUMPER

DRAWING NUMBER

E19

NOTES:

1. ITEMS INDICATED WITH " * " ARE PRE-ASSEMBLED.

DIRECTIONS:

1. Install vehicle specific base screw into your vehicle using a 19mm socket. *See Notes Below
2. Using the supplied button head screw, and any required spacers, install the E19 Loop assembly to the base screw installed in step 1.
3. Swing loop to identify the first point of contact with bumper, and install the rubber bumper to the back of the loop at this location.

* **Note:** Due to strength and vibration concerns, most tow hooks will only thread in a 1/2 turn by hand. If your hook fits like this, ensure it is threading in straight and not cross-threaded, and use a 19mm socket to slowly turn the screw in. It should screw in smoothly with consistent effort until it bottoms out. After initial install tools will likely not be needed. This is intentional and when comparing the threads of your Rennline tow hook to the factory tow hook, you will notice a substantial difference in thread profiles. This is also an important part of the design.

Towing Instructions: Always refer to your factory manual for towing instructions and be sure to never tow the vehicle at an angle. Vehicles must be towed straight on as advised in the factory manuals.

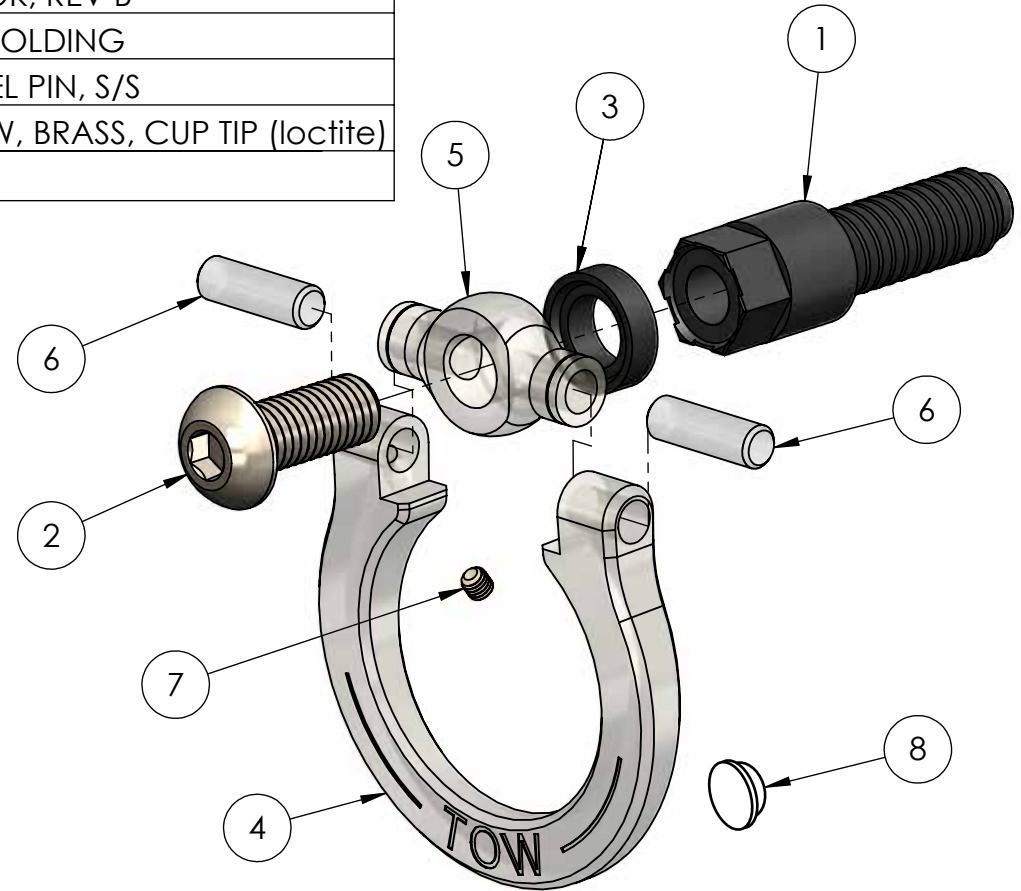

(802)893-7366
32 Catamount Dr.
Milton, VT, 05468

TITLE FOLDING TOW HOOK - ASSEMBLY B

DWG BY	DATE 7/18/2017	SHEET 1 OF 1	DRAWING NUMBER	REV
APR BY	DATE -	SCALE: 3:4	E19	A