

Project Name \_\_\_\_\_  
 Date \_\_\_\_\_ Part Number \_\_\_\_\_

**PRODUCT**

SKU	CLT-HBU-100W-11D-50
Item Number	CLT-20018
Color	White

**PRODUCT SPECIFICATION**

Wattage	100W	Voltage	120-277V
Lumens	15,321	Replacement Wattage	400
CCT	5000K	Input Current (A)	1.11
Dimmable	1-10V	Power Factor	> 0.9
Beam Angle (°)	90°	CRI	> 80
Operating Temperature (°F)	-40° to 122°F	THD	<20%
IP Rating	IP66	Diameter	11-inch
Rated Life	50,000 hrs		



**DIMENSIONS**

Length (in/mm)	-
Diameter (in/mm)	13.77 / 350
Height (in/mm)	7.44 / 189
Weight (lbs)	8.9

**CERTIFICATIONS**

DLC/ ENERGY STAR	DLC Premium
UL/ETL	ETL Sanitation
RoHS	Yes
LM79/LM80	Yes
FCC	Yes

**ACCESSORIES**

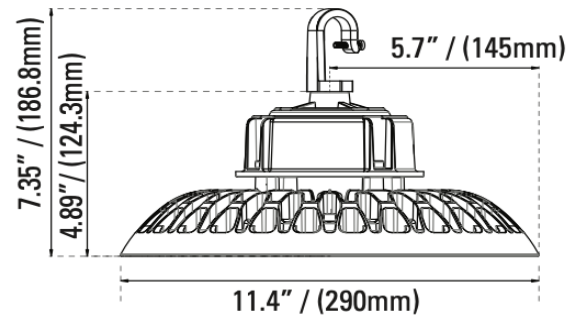
**APPLICATIONS**

- Warehouse Lighting
- Gymnasium
- Industrial Facility
- Commercial Lighting