

Project Name _____
 Date _____ Part Number _____

PRODUCT

SKU	CLT-EMD-15W-48VD-277-1
Item Number	CLT-40004
Color	White

PRODUCT SPECIFICATION

Input Voltage	120-277 Vac
Frequency	50/60 Hz
Input Current	100mA Max
Output Current	600mA (@25Vdc)~310mA (@48Vdc)
Output Voltage	25-48 Vdc
Wattage	15W Max
Charging Time	> 24 Hours Minimum
Discharging Time	90 Minutes Minimum
Operation Environment Temperature	32°F ~ 158°F
Battery Life	500 cycles
Primary Application	Indoor, Commercial, Residential
Certifications	UL, CEC (BC Mark)



DIMENSIONS

Length (in/mm)	7.4 / 188	9.0 / 228.6
Width (in/mm)	1.5 / 38.1	1.0 / 25.4
Height (in/mm)	1.2 / 30.48	1.0 / 25.4
Weight (lbs/oz)	1.85 / 29.6	

WIRING DIAGRAM

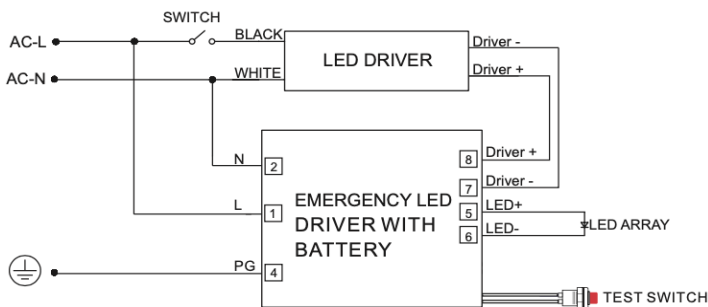

Cautions & Warnings: Contains Nickel-Metal-Hydride. Rechargeable Battery. Must be recycled or disposed properly.

Warning: To prevent high voltage from being present on LED (-) lead proper to installation, battery pack must be disconnected. Do not connect battery pack until installation is complete and AC power is supplied to the emergency driver