

REFRIGERATOR MANUFACTURER
Turbo air
 more durable, efficient, beautiful

4184 E. Conant St.
 Long Beach, CA 90808
 Tel. 310-900-1000
 Fax. 310-900-1077
www.turboairinc.com

Project :	
Model # :	
Item # :	Qty :
Available W/H :	
Approval :	

Beer Dispensers

*Underbar Equipment
 Super Deluxe Series*

Model : TBD-1SD/SB-N6



TBD-1SD-N6



TBD-1SB-N6

- Does not include keg couplers

≡ FEATURES & BENEFITS ≡

- **Hydrocarbon refrigerants (R-600a)**
 With innovative and eco-friendly technology, Turbo Air brings you hydrocarbon refrigerators designed to meet DOE's Energy Conservation Standards in 2017 and to use EPA's SNAP Program approved HC refrigerants. Hydrocarbon refrigerants do not deplete the ozone layer and have very low contribution to global warming (ODP-0, GWP-3).
- **Forced air cooling system**
 Fast cooling and balanced temperature throughout the cabinet.
- **Stainless steel cabinet construction**
 Super Deluxe (SD) models boast a stainless steel exterior (except galvanized steel back and bottom). SB models have an attractive wear-resistant black vinyl exterior. Heavy gauge stainless steel countertop is perfect for sanitation and durability. The interior is stainless steel except galvanized steel top. Spacious inside construction with 31 1/4" inner height accommodates various sizes of beer kegs. Turbo Air beer dispenser model guarantees the utmost in cleanliness and long product life. It also adds a touch of style to the most refined setting.
- **High-density polyurethane insulation**
 The entire cabinet structure is foamed-in-place using high density, HCFC free polyurethane insulation.
- **Ergonomically designed doors**
 Customers' fatigue fades away with easy grip handles and doors that open effortlessly. These features along with self-closing doors make this the ultimate choice in customer convenience.
- **3" diameter stainless steel insulated beer towers**
- **Comes standard with a two-way tapper manifold**
- **Beer dispenser holds 33°F ~ 38°F for the best in beverage preservation**



Model	Swing Door	1/2 Barrels	HP	AMPS	Crated Weight (lbs.)	L x D x H [†] (inches)
TBD-1SD-N6	1	1	1/8	1.1	198	23 5/8 x 31 3/4 x 38 7/8
TBD-1SB-N6	1	1	1/8	1.1	198	23 5/8 x 31 3/4 x 38 7/8

Model : TBD-1SD/SB-N6

ELECTRICAL DATA		
Voltage		115/60/1
Plug Type		Ⓜ NEMA 5-15P
Full Load Amperes		1.1
Compressor HP		1/8
Refrigerant		R-600a
Cord Length (ft.)		8.5
DIMENSIONAL DATA		
Net Capacity	(1/2 Barrels)	1
	(cu.ft.)	7.76
Ext. Length Overall (in.)		23 ⁵ / ₈ (600mm)
Ext. Depth Overall (in.)*		31 ³ / ₄ (806mm)
Ext. Height Overall (in.)†		38 ⁷ / ₈ (988mm)
Net Weight (lbs.)		175
Gross Weight (lbs.)		198
# of Swing Door		1
# of Casters		4EA

Design and specifications subject to change without notice.
Actual shipping weight may differ due to extra packing materials for product protection.
* Depth does not include 2" for rear spacers.
† Height does not include 5" for caster height. Height does not include 15-1/8" for draft arm.

■ **WARRANTY :** 3 Year Parts and Labor Warranty
Additional 4 Year Warranty on Compressor

■ STANDARD FEATURES

- Anti-corrosion coated evaporator
- Double faucet beer tower standard
- Door locks standard
- Self-contained system
- 4" dia. swivel casters standard

■ OPTIONAL ACCESSORIES :

- Triple faucet draft tower: 153A-3
- 6" adjustable stainless steel leg: P0121P0100

PLAN VIEW

(unit : inch)

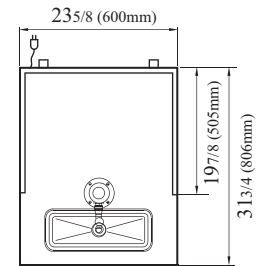

TOP VIEW

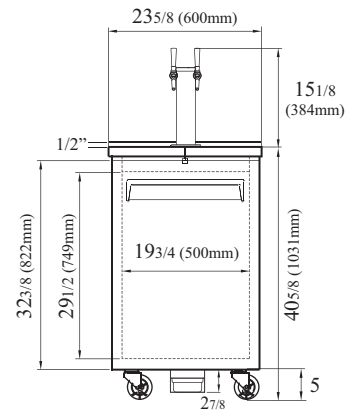

FRONT VIEW

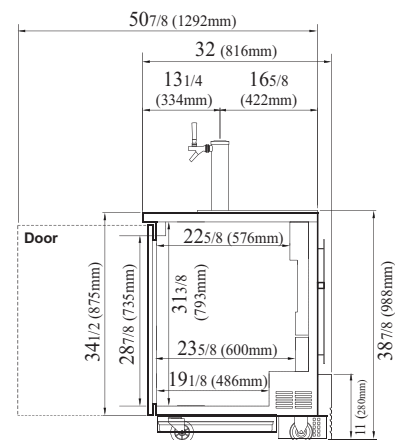

SIDE VIEW

Ver.20200706



- Turbo Air : 800-627-0032
- GK : 800-500-3519
- Warranty : 800-381-7770
- AC : 888-900-1002

