



Detroit Speed  
Subframe Connectors  
1979-93 Fox Body Mustang, 1979-86 Capri  
PN: 010114DS

The Detroit Speed Subframe Connectors are designed to give maximum torsional stiffness connecting the front and rear frame rails. They were designed to reinforce the torque boxes, the lower link pockets, the seat mounts, and the front sub rail, correcting known issues with this platform all in one component, saving the owner from spending time and money to replace multiple parts. These subframe connectors will connect the rear torque box structures to the front of the vehicle creating a continuous frame rail. They are fabricated from 2" x 2" x .083" wall steel tubing and .090 plate to increase the vehicle's stiffness without adding unnecessary weight. Stock suspension links are compatible. These rails do not affect ground clearance.



Scan the QR code to guide you through the step-by-step installation video of the 1979-93 Fox Body Mustang/ 1979-86 Capri DSE Subframe Connectors installation.

**Warning:** All work should be performed by a qualified welder and technician.

Item	Part Description	Quantity
1	Subframe Connector Welded Assembly – Front	2
2	Subframe Connector Welded Assembly – LH Rear	1
3	Subframe Connector Welded Assembly – RH Rear	1
4	Subframe Connector Seat Mount – LH	1
5	Subframe Connector Seat Mount – RH	1
6	M10-1.5 x 30 Flanged Hex Head Bolt	4
7	M10-1.5 Prevailing Torque Flanged Nut	4
8	Instructions	1

### **Tools Needed for Install:**

- Welding/Grinding PPE
- Welder
- Floor Jacks & Jack Stands
- Basic Hand Tools (Ratchet, Sockets & Wrenches)
- Body Clip Removal Tool or Flathead Screwdriver
- Razor Knife
- Pry Bar/Multi-Purpose Scraper
- Brake Line Flare Tool (If you plan to retain factory brake lines)
- Cut-Off Wheel
- Reciprocating Saw/Air Saw
- Grinder
- Drill
- Drill Bits (1/8", 3/8" or 3/4" Rotabroach)
- Mallet

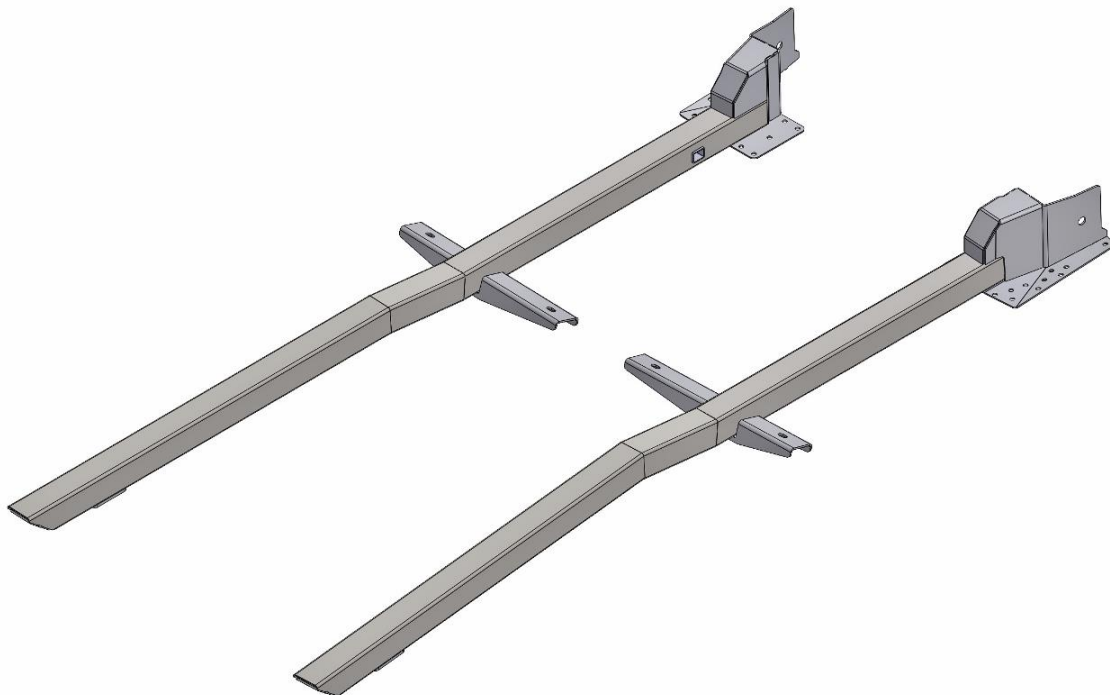

### **Installation:**

1. Raise the vehicle a few feet off the ground so the underside may be accessed. Begin by properly supporting the vehicle under the rear axle and the front lower control arms to avoid tension in the body when installing the connectors.

2. Disconnect the negative battery cable and remove the seats, carpet, and padding. Any interior panels that you are concerned with being damaged should be removed or masked to protect them from grinding and welding sparks (Figure 1).



Figure 1 – Remove/Mask Interior

3. Drill out or remove the body clips holding the fuel and brake lines in place (Figure 2). **CAUTION:** Make sure all brake, fuel and vent lines are away from areas to be cut.

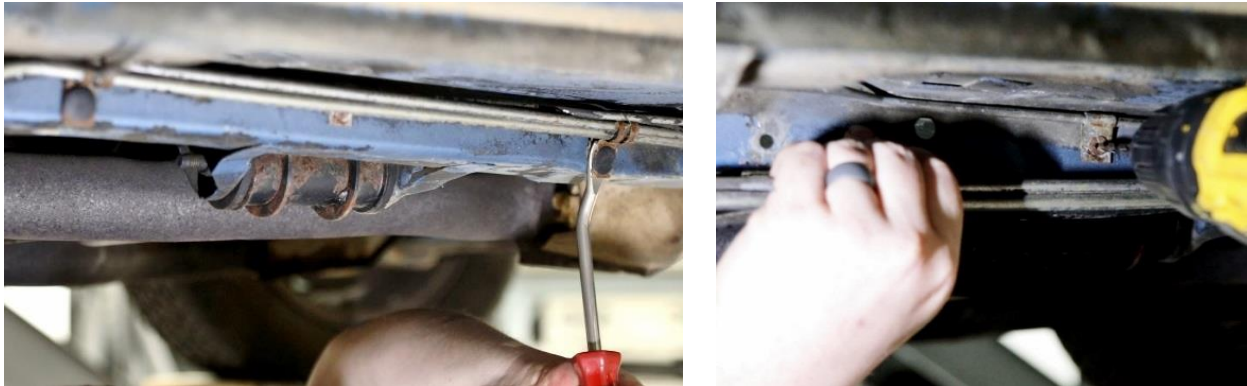

Figure 2 – Remove Fuel & Brake Line Clips

4. Remove the brake line clamp from underneath the vehicle on the passenger side and remove the fuel and brake lines away from the floor (Figure 3).



Figure 3 – Remove Brake Line Bracket

5. Remove a section of the heat/sound deadening material from the floor where it will need to be cut out for the connector. Use a knife to locate 1" on either side of the stamped bead continued to the front most edge of the floor pan and about 2" into the toe board (Figure 4).

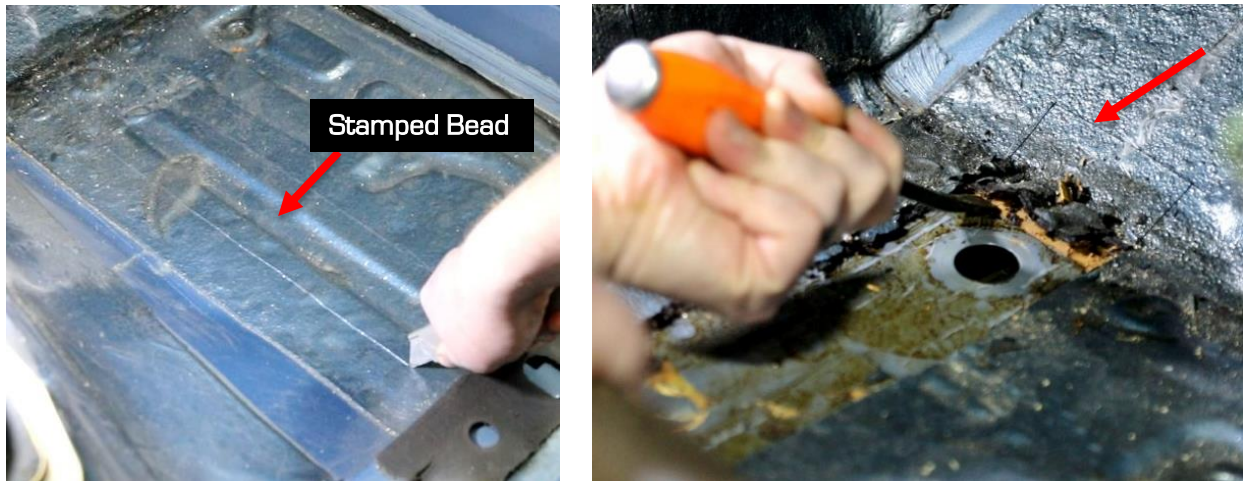

Figure 4 – Remove Floorboard Material

6. Remove the seam sealer at the front and rear corners of the floor pan at the rocker in order to take measurements from this area (Figure 5).



Figure 5 – Remove Seam Sealer

7. Clean the floor pan cut area. Remove the foam from the top of the front seat crossmember (Figure 6).



Figure 6 – Clean Cut Area and Remove Foam

8. To locate the subframe connector location, mark on both sides of the base of the front seat crossmember at 9" and 11-1/4" measured off the inside of the rocker (Figure 7).



Figure 7 - Mark Seat Riser

9. Now, mark on both sides of the base of the seat crossmember at 8" and 12-1/2" measured off the inside of the rocker. Draw a cut line around the seat crossmember at these marked locations. This section will be cut out to give you enough room to have welding access for the subframe connector (Figure 8).

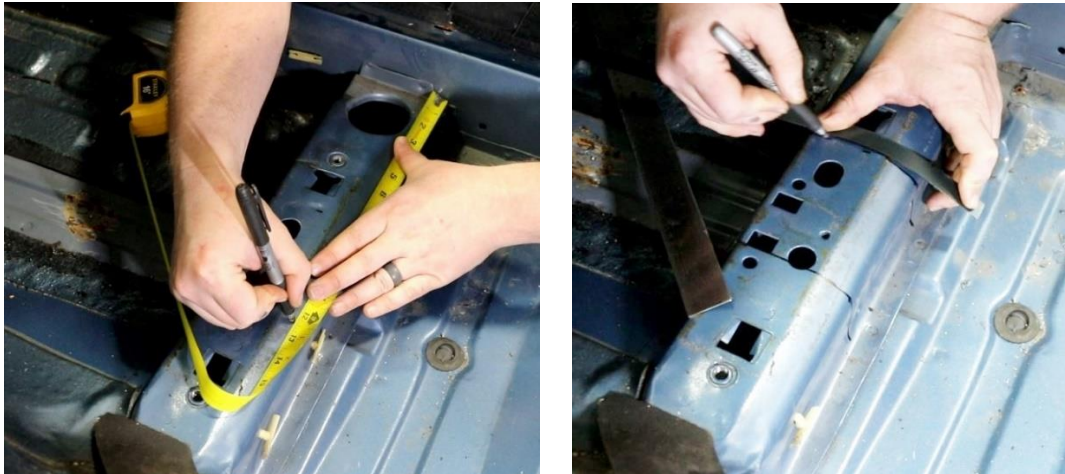

Figure 8 - Mark Cut Lines

10. Using a cut-off wheel, remove the middle section of the seat crossmember at the base and between the 2 marked lines from the previous step flush to the floor pan. Remove this piece and save it for later (Figure 9).

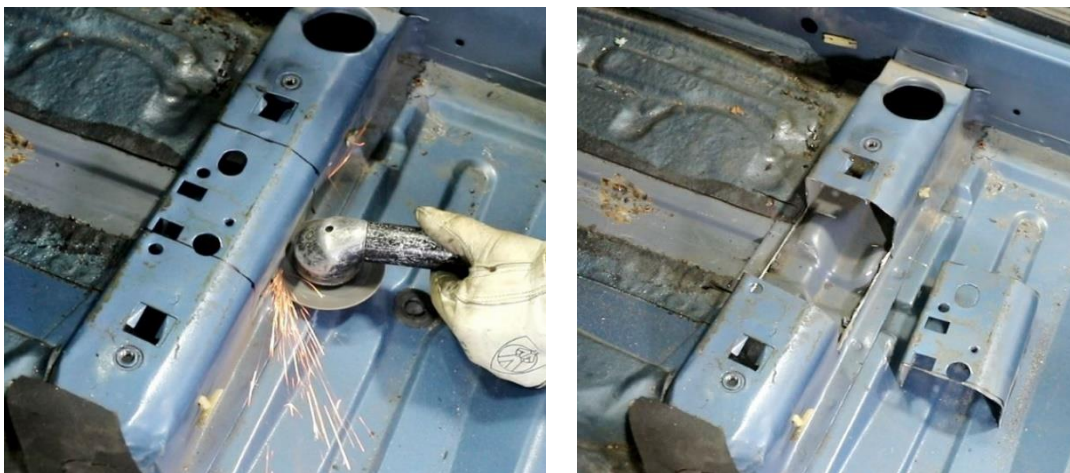

Figure 9 - Remove Seat Riser Section

11. Use the passenger side blueprint (Figure 10) to lay out your floor pan cut lines along with Steps 12-16. **NOTE:** The mirror image of the blueprint can be used for the driver side.

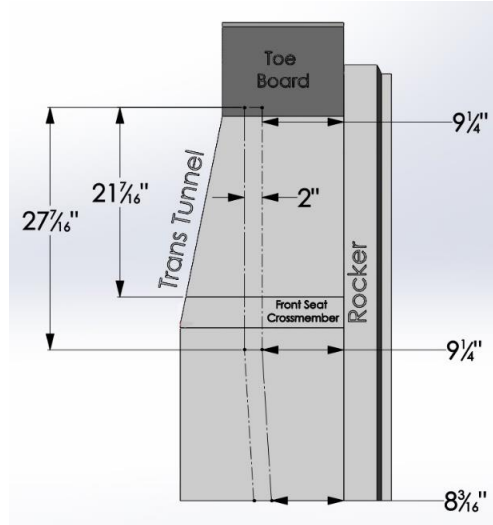

Figure 10 - Floor Cut Lines

12. From the front side of the base of the seat crossmember, measure forward  $21\text{-}7/16$ " and mark the location on the toe board (Figure 11).



Figure 11 - Mark Front of Cut Area

13. Measure inboard from the rocker  $9\text{-}1/4$ " and mark the location (Figure 12).



Figure 12 - Locate Cut Line

14. Using the location marked in the previous step, draw a straight cut line rearward past the seat crossmember area (Figure 13).



Figure 13 - Mark Outboard Cut Line

15. Mark the inboard cut line by offsetting the cut line from the previous step, 2" inward. Mark two locations and draw a straight cut line between the two points. Draw a perpendicular line to connect the two cut lines at the front from the marked location from Step 12 (Figure 14).



Figure 14 - Mark Inboard Cut Line

16. Measure back 27-1/4" from the front cut line and mark the rear cut line (Figure 15).

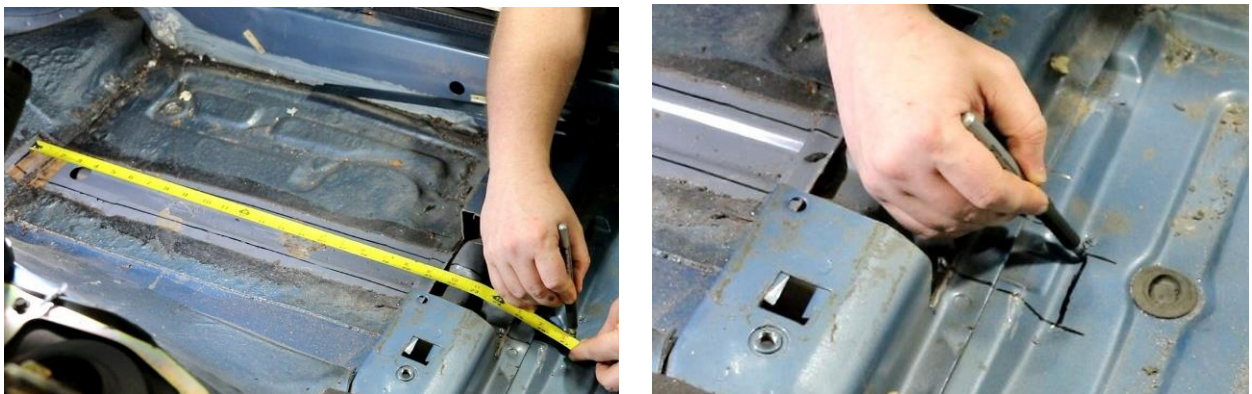

Figure 15 - Mark Rear Cut Line

17. Using a cut-off wheel, remove the top layer of the floor pan section **inside** the cut lines (Figure 16). **CAUTION:** Be careful not to cut into the frame rail, be certain to only cut the top layer of the floor pan.



Figure 16 - Cut-Out Floor Section

18. Remove the floor pan bracket underneath the cut area (Figure 17).



Figure 17 - Remove Floor Pan Bracket

19. Grind the floor pan cut lines smooth (Figure 18).



Figure 18 - Grind Cut Lines

20. Continue to remove the top floor layer under the seat crossmember using a cut-off wheel. Cut in front of the rear cut line where the floor pan drops down to remove this section of floor (Figure 19).



**Figure 19 – Remove Floor under Seat Riser**

21. From underneath the vehicle, cut a square shape through the floor behind the seat riser for the subframe connector pass through (Figure 20).



**Figure 20 – Cut-Out Pass through Location**

22. Grind away any burrs in the channel where the front subframe connector will sit. Also make sure you have sharp edges at the corners and fix any dents in the factory rail. The connector needs to fit as flush to the channel as possible. (Figure 21).



**Figure 21 – Grind Away Burrs**

23. Place one of the front subframe connectors into the channel in the floor. Use a soft hammer to tap it gently forward and down into the channel (Figure 22).



Figure 22 – Install Front Subframe Connector Assembly

24. Mark a location at the base of the rear seat riser, 8-3/16" from the inside rocker. Use this mark and the front connector to draw a straight cut line on the floor pan (Figure 23).

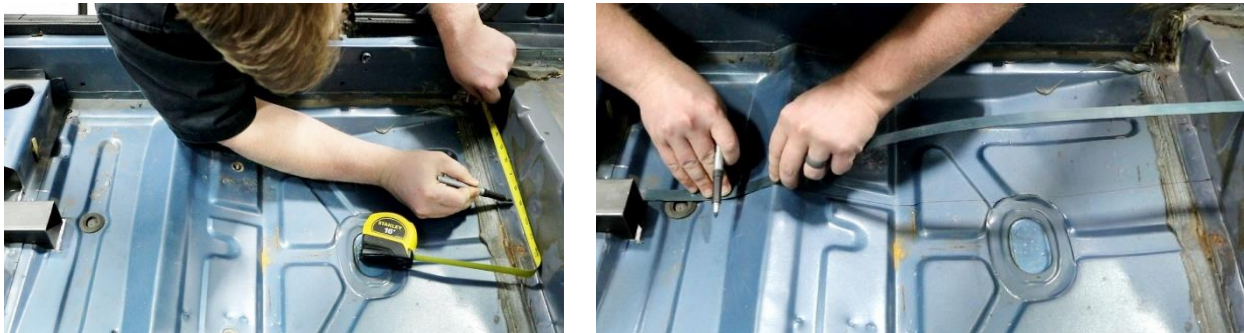

Figure 23 – Mark Outboard Cut Line

25. Measure 2" inboard of the cut line from the previous step and mark a few locations on the floor pan. Use these marked locations along with the inboard side of the front connector to draw a straight cut line (Figure 24).

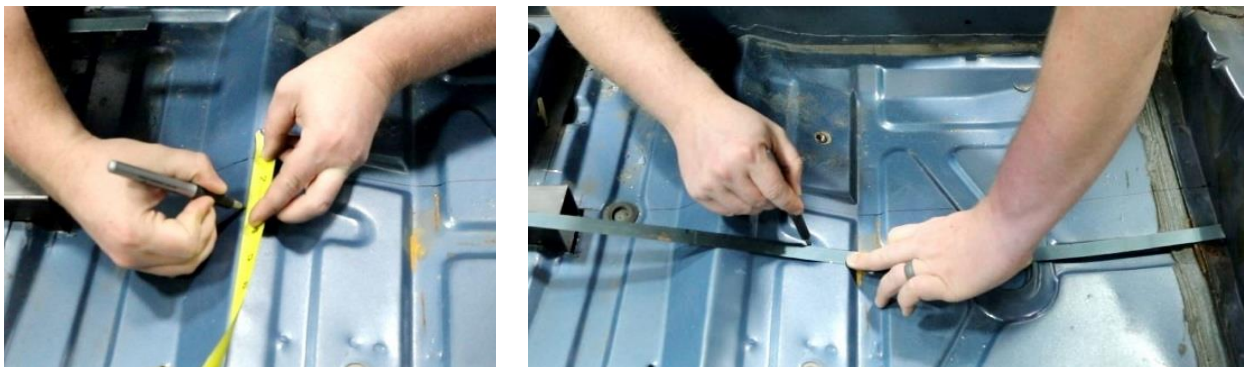

Figure 24 – Mark Inboard Cut Line

26. Remove the rubber grommet from the floor. Using a cutoff wheel, remove the section of floor pan between the cut lines (Figure 25).



Figure 25 - Cut Floor Pan

27. From underneath the vehicle, mark a location on the front side of the lower link pocket 2" outboard of the frame rail. Mark another location, 2" above (Figure 26).



Figure 26 - Locate Lower Link Pocket

28. Project another location using a straight edge, leveled off the floor pan onto the front side of the lower link pocket. Draw a vertical line connecting this mark with the 1st marked location in the previous step (Figure 27).

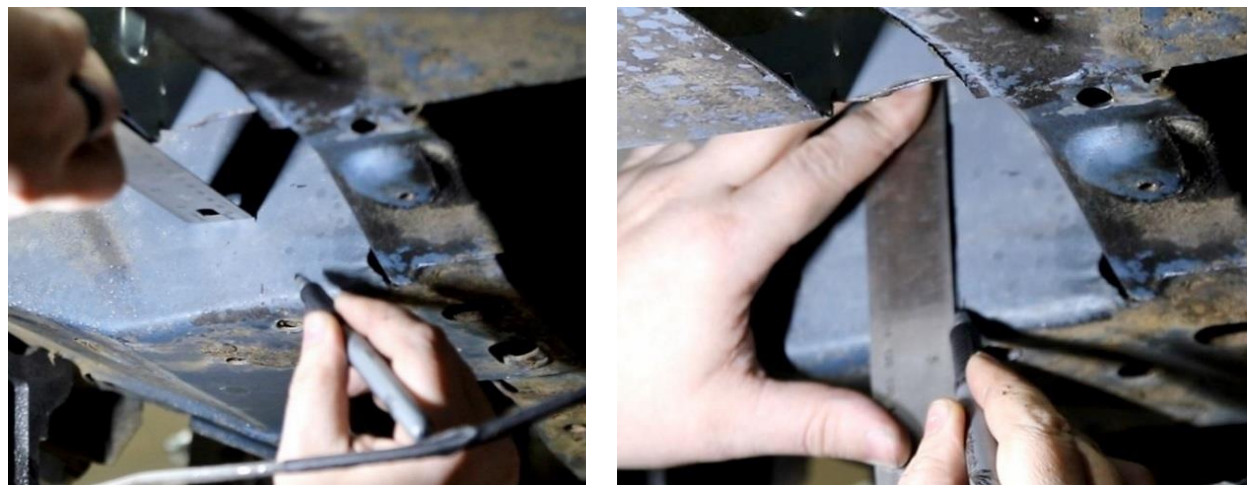

Figure 27 - Locate Torque Box Cut Lines

29. Draw a horizontal line connecting the marked location from Step 28 intersecting with the vertical line in the previous step. Transfer a cut line onto the bottom side of the lower link pocket using the vertical line as a reference (Figure 28).



Figure 28 - Project Cut Lines

30. Draw another cut line on the bottom side of the lower link pocket in line with the outside frame rail and parallel to the cut line drawn in the previous step. Cut this section out using the drawn lines for reference (Figure 29).

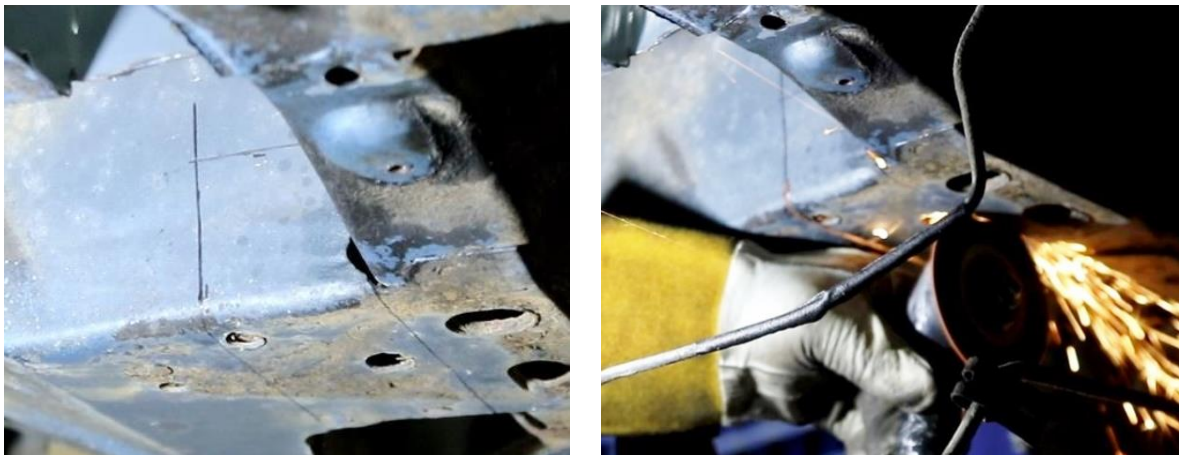

Figure 29 - Draw Cut Lines

31. Draw a cut line on the bottom side of the lower link pocket connecting the outboard corner that was cut in the previous step and 1/4" from outside of the lower link pocket. Cut this section out using the drawn lines for reference (Figure 30).

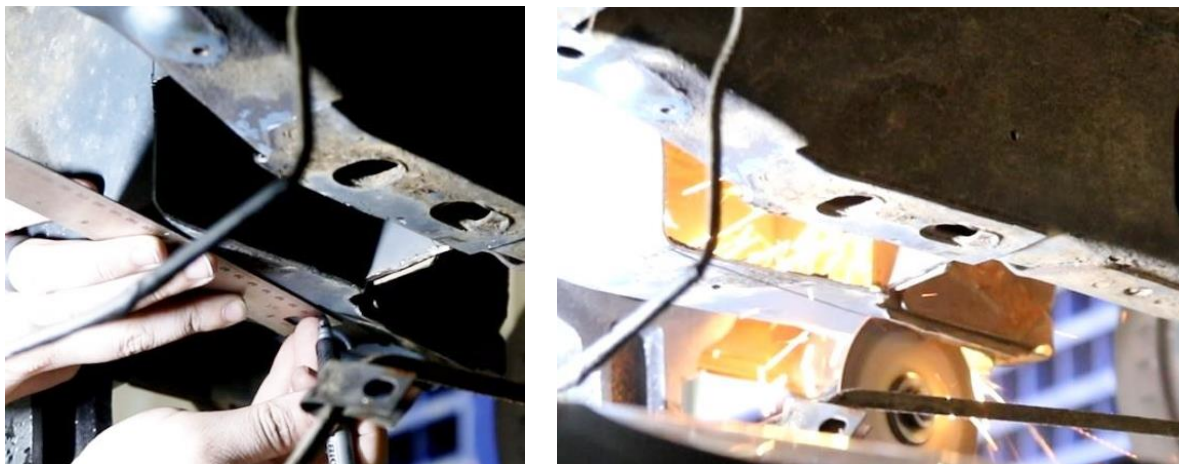

Figure 30 - Trim Lower Link Pocket

32. Measure the center of the frame rail in the lower link pocket and mark the location. Draw a straight vertical line using this mark. Measure up 1" from the bottom edge of the lower link pocket and mark the intersection. Measure up another 2" and mark a 2nd location intersecting the vertical line (Figure 31).



Figure 31 - Locate Plug Weld Holes

33. Drill two pilot holes at the marked locations from the previous step. Using a Rotabroach or small hole saw, drill a 3/4" hole at both of these locations (Figure 32). **NOTE:** You could also drill three 3/8" holes on this surface if you do not have a 3/4" Rotabroach as these will just be plug weld holes.



Figure 32 - Drill Plug Weld Holes

34. At the front of the frame, drill a pilot hole in the middle of the frame rail where the doubler plate overlaps the frame. Using a Rota-broach or a hole saw, drill a 3/4" hole at this location (Figure 33 on the next page). **NOTE:** You could also drill two 3/8" holes on this surface if you do not have a 3/4" Rotabroach as these will just be plug weld holes.

**CAUTION:** Be careful as you drill the 3/4" hole as you will cut through the doubler plate first and then the frame rail material. Let the tool do the cutting so it doesn't move off location.

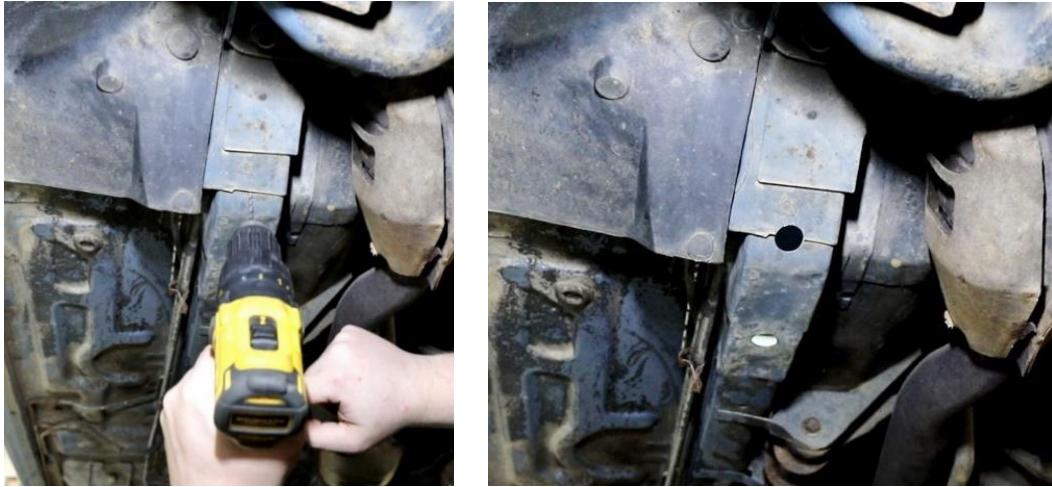

Figure 33 - Drill Plug Weld Location

35. Mark two hole locations at the floor plan, next to the frame rail flange from underneath the vehicle, starting  $\frac{3}{4}$ " in front of the lower link pocket. The 2nd hole will be located  $1\frac{1}{2}$ " forward of the 1st hole. Drill out the marked locations with a pilot drill from underneath the vehicle. Next, from inside the vehicle, use a  $\frac{3}{4}$ " Rotabroach to open up the pilot holes (Figure 34). **NOTE:** The holes will be through the frame rail flange directly above the rear torque box (Reference Step 57).

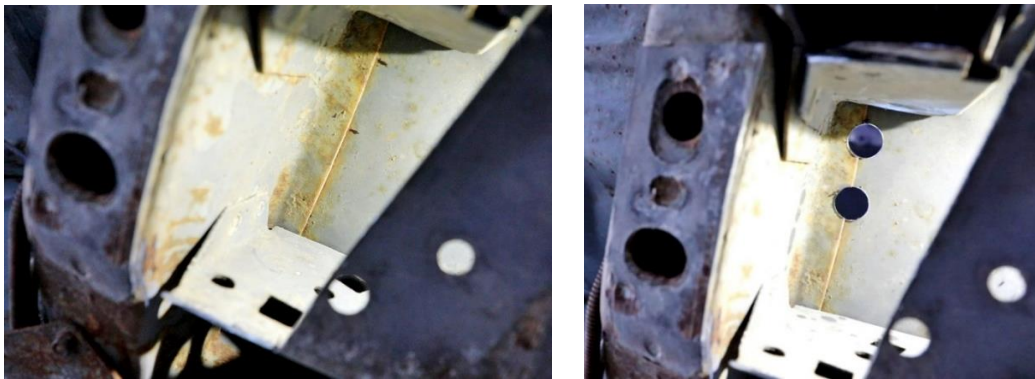

Figure 34 - Drill Plug Weld Holes

36. Install the rear right hand subframe connector assembly from underneath the vehicle so it meets up with the back of the front subframe connector assembly. Use a clamp to hold the torque box assembly in place (Figure 35). **NOTE:** Based on variation of this body style, the front connector may need to be trimmed (since it is a straight cut, and the rear connector is not a straight cut) to allow between a  $\frac{1}{32}$ " to a  $\frac{1}{16}$ " welding gap between the front and the rear connector.



Figure 35 - Clamp Rear Connector Assembly in Place

**NOTES:** 1. You may need to flatten the flange so the torque box can sit flush to the vehicle.

2. Due to vehicle variation from 1979-93, the lower link bolt hole may not line up with the clearance hole on the torque box. If the holes are close to lining up, open up the **clearance hole (NOT the link hole)** on the torque box so the lower link bolt will pass through the lower link hole and the torque box. If the holes are not close to lining up, look for fitment issues as to why the clearance hole and the lower link hole are not close to lining up (Figure 36).

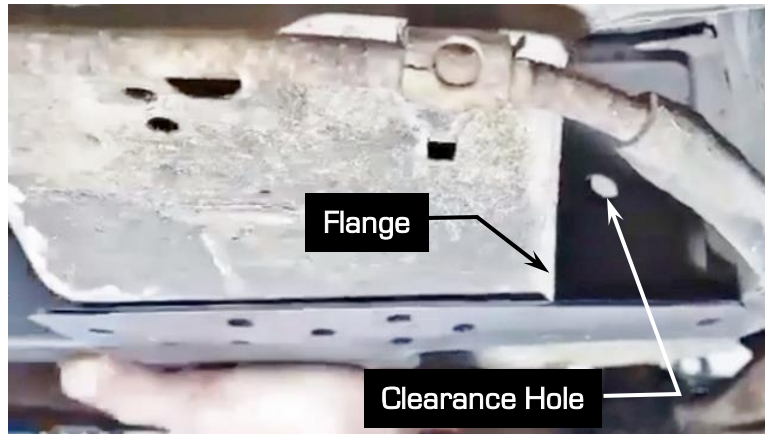

Figure 36 - Torque Box Notes

37. Place the seat crossmember section that was cut out in Step 10 onto the front subframe connector and measure the distance it sits above the seat crossmember. Draw a cut line onto the seat crossmember section from the bottom edge with that measurement (Fig. 37).

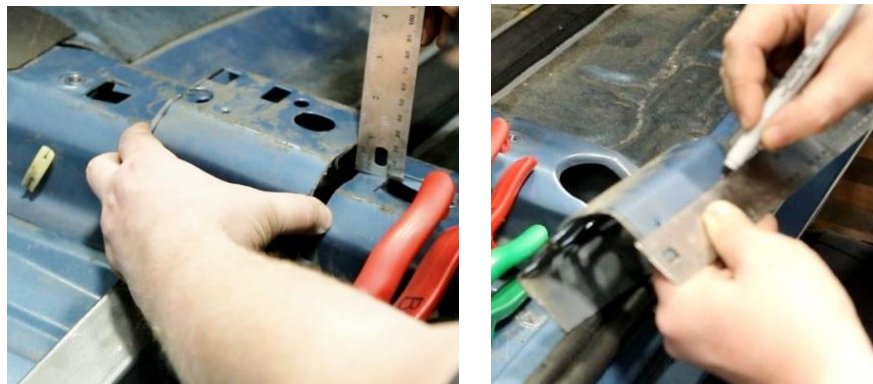

Figure 37 - Measure Cut Line

38. Measure the width of the seat crossmember section that needs to be cut by putting it back in place and transferring cut lines from the subframe connector onto the sheet metal (Fig. 38).

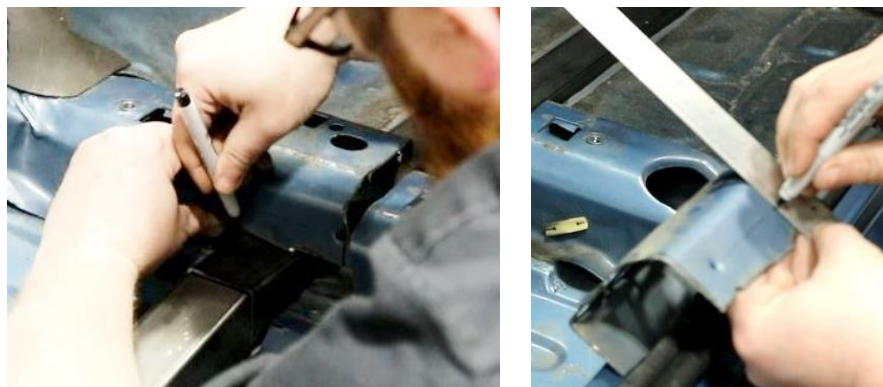

Figure 38 - Draw Cut Lines

39. Use a pair of snips to cut out a pocket to fit over the subframe connector. Place the seat crossmember section back over the connector and make sure it fits around the connector (Figure 39).



**Figure 39 - Fit Seat Riser**

40. Remove the front and rear frame connectors. Prepare the floor pan on the top and bottom side for welding by removing all paint and dirt and as much aluminized coating as possible (Figure 40).



**Figure 40 - Prepare Floor Pan**

41. Place the front subframe connector into the channel in the floor pan. Make sure it is clean of any debris. Tap the connector forward and down until it is seated in place (Figure 41).



**Figure 41 - Locate Front Connector**

42. From underneath the vehicle, prepare for welding by grinding a smooth, clean surface around the three existing holes. Weld the connector in place using these holes (Figure 42).



**Figure 42 – Weld Front Connector**

43. Weld the back of the front connector to the end of the channel in the floor pan (Figure 43).



**Figure 43 – Weld Back of Connector**

44. From inside the vehicle, weld along the front and sides of the front connector to the floor pan (Figure 44).



**Figure 44 – Weld Sides of Connector**

45. Re-position the section of seat crossmember that was removed in Step 10 and place it over the subframe connector. Tack weld it in place and then finish weld around the seat crossmember and connector (Figure 45).

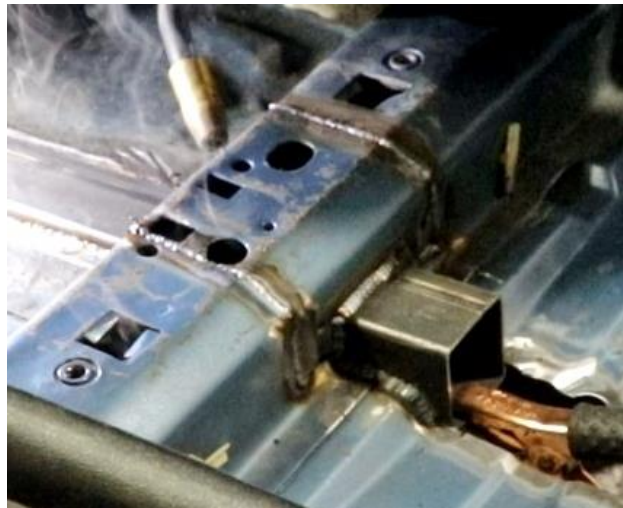

Figure 45 - Weld Seat Riser Section

46. Position the rear subframe connector assembly from underneath the vehicle so it lines up with the back of the front connector. Tap the torque box assembly of the rear connector up into place using a hammer. **NOTE:** Be sure all brake and fuel lines are out of the way. Place a clamp between the floor pan doubler and the vehicle to hold it in place (Figure 46).



Figure 46 - Locate Rear Connector

47. Tack weld both sides of the front and rear connector together (Figure 47).



Figure 47 - Weld Sides of Connector

48. Clamp the torque box assembly on the rear connector to the vehicle. Then, install the stock trailing link bolt through the torque box assembly and lower trailing link hole in the vehicle and tighten (Figure 48).

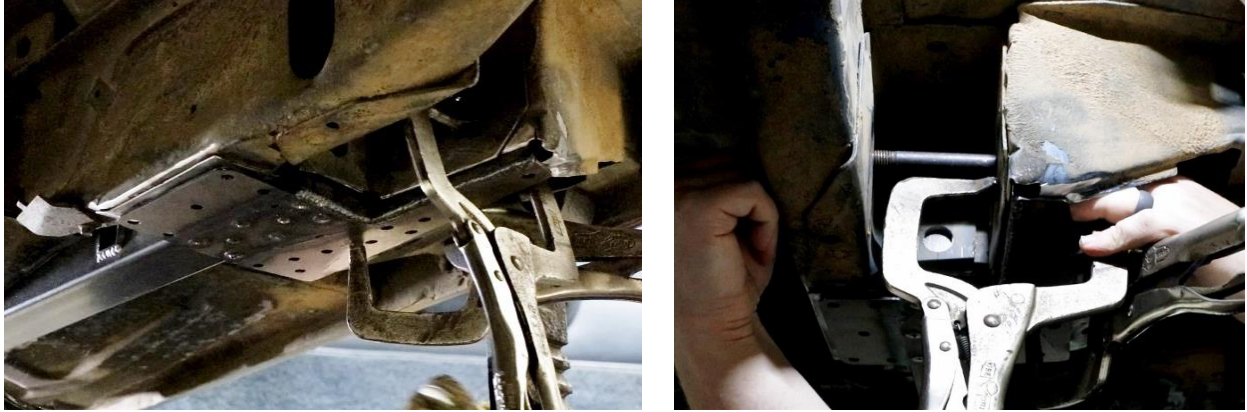

Figure 48 – Position Torque Box Assembly

49. From inside the vehicle, tack weld the torque box assembly through the existing hole in the floor pan (Figure 49). **NOTE:** The inner wheel tub has been removed in this picture.



Figure 49 – Tack Weld Torque Box

50. Using a piece of wood, put pressure on the floor doubler of the torque box to hold it tight to the vehicle. Tack and plug weld the torque box assembly in place. Then, finish weld the floor doubler to the vehicle (Figure 50).



Figure 50 – Weld Doubler Plate

51. Re-position the clamps to finish plug welding the torque box assembly to the vehicle [Fig 51].



Figure 51 – Plug Weld Torque Box

52. Weld around the rear connector to the floor pan in front of the torque box from underneath the vehicle [Figure 52].



Figure 52 – Weld Rear Connector

53. Finish welding the torque box assembly to the lower link pocket. Weld the floor pan doubler to the bottom of the frame rail. Then, Rosette weld the lower link pocket to the torque box assembly [Figure 53].



Figure 53 – Weld Link Pocket

54. We also recommend seam welding the sheet metal of the lower link pocket to the frame rail as well as welding the inside of the link pocket (Figure 54).



**Figure 54 - Weld Factory Sheet Metal**

55. Install the subframe connector seat mount around the rear connector using the provided M10-1.5 x 30mm hex head flanged bolts and nuts. They will install in the factory seat location from the bottom side of the floor pan (Figure 55).



**Figure 55 - Install Seat Mount**

56. Tighten the M10 fasteners and then weld the seat mount bracket to the rear connector. From inside the vehicle, weld the rear connector to the floor pan above the seat mount (Figure 56).



**Figure 56 - Weld Seat Mount**

57. From inside the vehicle, rosette weld the two 3/4" holes you drilled in Step 35. This will weld the floor pan to the top of the torque box assembly and frame rail. Then, weld the rear seat riser around the rear connector where it passes through (Figure 57).



**Figure 57 - Weld Seat Riser to Connector**

58. From inside the vehicle, weld the sides and top of the front and rear connector together (Figure 58).

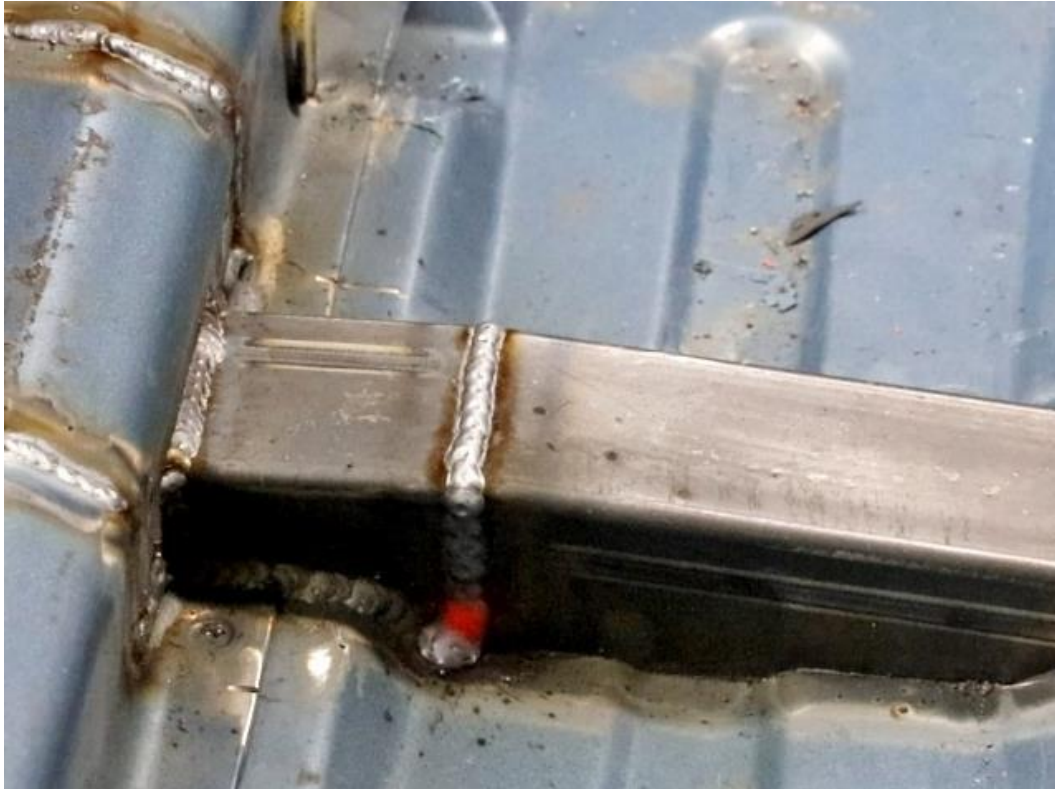

**Figure 58 - Weld Front & Rear Connector**

59. From underneath the vehicle, weld the floor pan around the rear connector on both sides (Figure 59 on the next page).



**Figure 59 – Finish Weld Rear Connector**

60. Repeat this subframe connector installation process for the opposite side of the vehicle.

61. Splice the brake and vent lines at the location below. Add a double flared union at that location in the brake line. For the breather, join it together with a piece of fuel safe rubber hose (Figure 60).



**Figure 60 – Secure Brake & Fuel Lines**

62. After all welding and grinding is complete, reinstall the fuel line with pop rivets being sure to gently reshape the fuel line where it crosses the connector (Figure 61).



**Figure 61 – Secure Fuel Lines**

63. Paint the newly installed subframe connectors and surrounding areas as desired to protect from corrosion. We also recommend using seam sealer as needed (Figure 62).



**Figure 62 – Finished Installation**

64. You have finished the installation of your subframe connectors, you can now reinstall the interior.

### **Notes on SN95 Installation**

Ford added extra sheet metal to the SN95 chassis for improved structural integrity. The Detroit Speed Subframe Connectors will fit the SN95 cars with a little extra cutting and clearance. The floor of the SN95 car is very similar to the Fox Body. The majority of the differences lie within the lower torque boxes.

Detroit Speed recommends starting to cut at the front of the car. Hold the subframe connector up in the car as you cut toward the back to help visualize where the extra cutting and clearance must occur. Cut and trim sheet metal to align lower control arm hole in subframe connector as close as possible to original lower control arm hole in chassis.

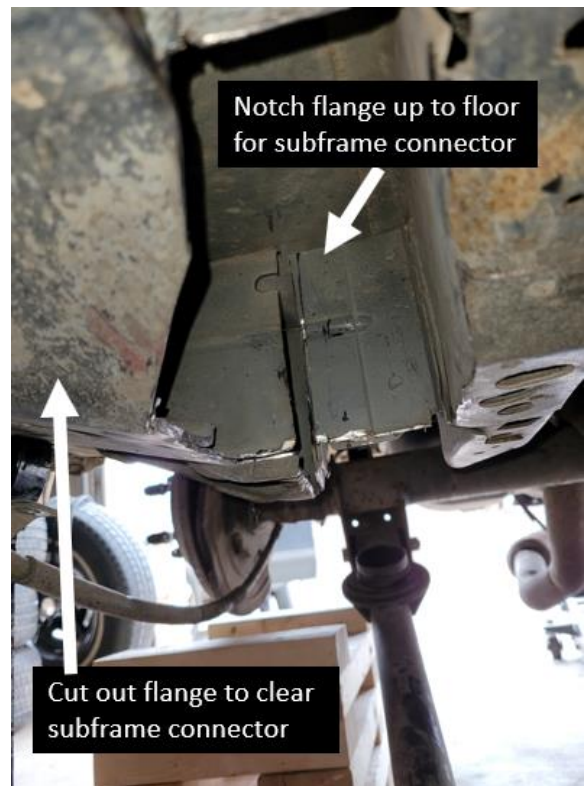
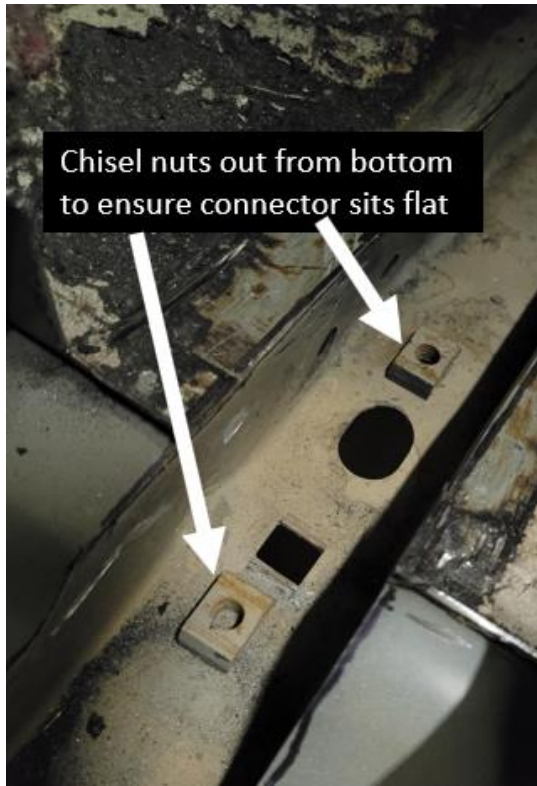

If you have any questions before or during the installation of this product, please contact Detroit Speed Inc. at [tech@detroitsspeed.com](mailto:tech@detroitsspeed.com) or 704.662.3272

**Legal Disclaimer:** Detroit Speed, Inc. is not liable for personal, property, legal, or financial damages from the use or misuse of any product we sell. The purchaser is solely responsible for the safety and performance of these products. No warranty is expressed or implied.