

Detroit Speed  
Chevy II Front Frame  
1962-1967 Chevy II

P/N: 032031DS, 032031-SDS, 032031-DDS, 032031-RDS, 032032DS, 032032-SDS, 032032-DDS, 032032-RDS, 032033DS, 032033-SDS, 032033-DDS, 032033-RDS, 032034DS, 032034-SDS, 032034-DDS, 032034-RDS, 032039DS, 032039-SDS, 032039-DDS, 032039-RDS, 032040DS, 032040-SDS, 032040-DDS & 032040-RDS

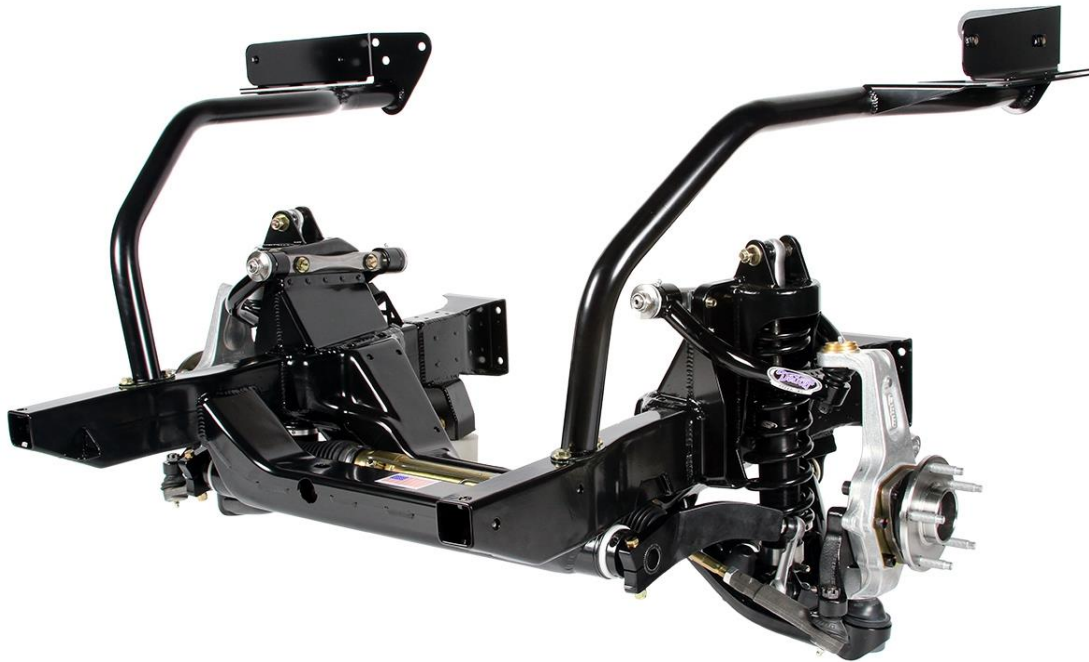

## INTRODUCTION

The Detroit Speed 1962-67 Chevy II Front Frame is a bolt-in replacement for the original stock frame. It improves handling and ride quality by utilizing DSE's unique suspension geometry. It is the only Chevy II frame in the aftermarket industry with OEM quality stamped crossmembers for improved structural rigidity. The bay bars feature rigid integral hood hinge mounting and are hidden when used with Detroit Speed's Chevy II Inner Fender package.

The Detroit Speed front frame has been designed, engineered, and developed for the road and track. This subframe blends the benefits of current OEM technology and aftermarket performance into one product.

The Detroit Speed Chevy II Frame has the following features:

- Mandrel bent frame rails and stamped crossmembers
- Detroit Speed optimized suspension and steering geometry
- Ability to accommodate small block Chevrolet engines as well as LS1, LS2, LS3, and LS7 engines
- Aluminum body coilover shocks with "Detroit Tuned" valving
- Splined sway bar
- Power rack and pinion steering

Specifications - Detroit Speed Chevy II Frame	
Total Suspension Travel	6"
Ride Height*	1.5" ± 1.0"
Static Camber	- 0.5° ± 0.2°
Static Caster	+7.0° ± 0.5°
Static Toe	0.0° ± 0.1°
*Measured from the top of the framerail to the center of the hub	

Engine Fitment - Detroit Speed Chevy II Frame				
SBC Engines				
Engine	Mounting	Oil Pans	Headers	Comments
Small Block Chevrolet	DSE Engine Mounting Kit P/N: 060415	Stock	DSE Headers P/N: 061003 P/N: 061004	
LS Engines				
Engine	Mounting	Oil Pans	Headers	Comments
LS1, LS2, LS3	DSE Engine Mounting Kit P/N: 060416	LS2/LS3 Corvette GM P/N: 12624617  4 <sup>th</sup> Gen F-Body GM P/N: 12628771  Mast P/N: 401-111 Holley P/N: 302-2, 302-3 or 302-5 <b>(Mast &amp; Holley pans are not compatible when using DSE Chevy II headers)</b>  Champ P/N: LS1000	DSE Headers P/N: 061002	A/C compressor will need to be relocated to the top of the engine to clear the crossmember. Use Holley or Vintage Air front drive system
LS7*, LS9	DSE Engine Mounting Kit P/N 060416	Corvette Dry Sump Pan GM P/N: 12626225		A/C compressor will need to be relocated to the top of the engine to clear the crossmember. Use Holley or Vintage Air front drive system. Need to use Camaro style damper/pulley

**\*NOTE: For aftermarket LS engines (i.e., Mast Motorsports), refer to manufacturer for specific oil pan usage and use chart above for correct Detroit Speed Engine Mounting Kit.**

Accessory Components - Detroit Speed Chevy II Frame	
<b>Brakes</b>	Detroit Speed has Baer and Wilwood brake packages for our frame. Any C6 Corvette brake application will work with our frame.
<b>Rack &amp; Pinion Fittings</b>	Return (low): 5/8" - 18 - Pressure (high): 9/16" - 18 Fittings to adapt to -6 AN and complete hose kits are available from Detroit Speed
<b>Rack &amp; Pinion Input Shaft</b>	3/4"-36, Complete kits available from Detroit Speed
<b>Wheel Stud Kit (Optional)</b>	ARP 100-7708 - M12-1.5 x 2.5" L GM Wheel Stud Kit

Wheel Fitment-Detroit Speed Chevy II Frame 1962-65					
Diameter (in)	Width (in)	Backspacing (in)	Bolt Pattern/ Lug Nut Thread Pitch	Recommended Tire	Comments
17	8.0	4.5	5 X 4.75" M12x1.5	245/40R17	
	8.5	4.75		245/40R17	Maximum width recommended
18	8.0	4.5		245/35R18	
	8.5	4.75		245/35R18	
	9.0	5		255/35R18	Maximum width recommended

**\* 17" wheels require a minimum inside wheel diameter of 16.250"**

**CAUTION:** Some brake applications will not work with 17" wheels. Flush mount valve stems may also be required on wheels with a behind center valve stem location.

Wheel Fitment-Detroit Speed Chevy II Frame 1966-67					
Diameter (in)	Width (in)	Backspacing (in)	Bolt Pattern/ Lug Nut Thread Pitch	Recommended Tire	Comments
17	8.0	4.5	5 X 4.75" M12x1.5	245/40R17	
	8.5	4.75		245/40R17	
	9.0	4.75		255/40R17	Maximum width recommended
18	8.0	4.5		245/35R18	
	8.5	4.75		245/35R18	
	9.0	5		255/35R18	
	9.5	5		265/35R18	Maximum width recommended

Fastener Torque Specifications - Detroit Speed Chevy II Frame		
Application	Torque (ft-lb)	Threads
Lower Control Arm Mounting Bolts	95	Anti-Seize
Rack and Pinion Mounting Bolts	95	Anti-Seize
Sway Bar Support Screws	20	
Sway Bar Shaft Clamp Screw	14	Blue Loctite 242
Sway Bar Link Nuts	45	Red Loctite 262
Upper Control Arm Crossshaft Mounting Bolts	50	Red Loctite 262
Upper Coilover Shock Mounting Bolts	60	Anti-Seize
Lower Coilover Shock Tie Bar Bolts	35	Anti-Seize
Sway Bar Arm Mounting Bolt	25	Anti-Seize
Tie Rod End Jam Nut	45	Anti-Seize
Upper Control Arm Ball Joint Stud Nut	40	
Lower Control Arm Ball Joint Stud Nut	20 then turn an additional 180°	Red Loctite 262
Tie Rod End Stud Nut*	35	Anti-Seize
Wheel/Hub Bearing Mounting Bolts	95	Red Loctite 262
Steer Arm Mounting Bolts	60	Red Loctite 262
Front Brake Caliper Mounting Bracket Bolts	125	
Wheel Stud Nuts	100	
Down bar to Frame Bolts	30	
Frame to Body Bolts	50	
Down bar to Body Bolts	30	
Hood Hinge Bolts	30	
Radiator Support Bolts	30	
Bumper Bolts to Frame	50	
*Always tighten slotted nuts to line up with the cotter pin hole when applicable.		

## **IMPORTANT:**

1. If you have purchased the bare metal, unassembled option for the Detroit Speed Chevy II Front Frame, the upper and lower control arms **CANNOT** be powder coated since they come already assembled from DSE. The temperatures from this process will destroy the control arms beyond repair. The Detroit Speed upper control arms **CANNOT** be taken apart because of the precise assembly procedure at DSE. The upper control arm cross shaft nuts are torqued and then pinned in place. Failure to follow the correct procedure will damage the upper control arms beyond repair. Any attempt at taking apart any of the Detroit Speed subframe components before calling DSE will void any warranty. If you have any questions, please call Detroit Speed at 704-662-3272.
2. If the lower control arm ball joint stud needs to be serviced after the initial torque setting listed above for a coilover spring change, etc. use the following information to re-assemble the lower control arm and upright:
  - a) Before you remove the ball joint nut, make a line with a marker from the top of the nut down to the upright and then loosen the ball joint nut.
  - b) Upon re-assembly, torque the ball joint nut to 20 ft-lbs. and then tighten the nut until the line on the nut goes back to the line on the upright so it is back in the same location as the initial torque setting.
3. If the upper ball joint needs to be replaced, the Detroit Speed upright assembly must be returned to DSE to be serviced. Failure to follow this procedure before calling DSE will void any warranty. If you have any questions, please call Detroit Speed at 704-662-3272.
4. If you have a 1962 Chevy II, the hood hinges are specific to that year as the mounting pattern is narrower than the 1963-67 Chevy II model years. With the Detroit Speed Front Frame and Detroit Speed inner fenders, you will need to use the 1963-64 hood hinges on your 1962 Chevy II model year.

## **CAUTION:**

The Detroit Speed serial number tag is the best identification record of your front frame when contacting DSE to determine when your front frame was assembled for any warranty issues should you need them. See Figure 1. For customers that have ordered the raw front frame we recommend not powder coating the frame as that will cause permanent damage to your serial tag number. If it is damaged it would be much more difficult to properly ID your Detroit Speed front frame.



Figure 1 – Front Frame Tag

**NOTE:** Be sure the frame rails are free of any loose media or particles that may have collected in the rails from paint or powder coat. Do this with compressed air. Pay particular attention to the front crossmember. Any foreign particles left in the front crossmember could possibly damage the sway bar end support bushings.

1. **Install lower control arm assemblies.**

- a) Install the correct lower control arm (driver or passenger side). This is referenced by the bump stop being located on the forward tube of the control arm. See Figure 2.



Figure 2 - Passenger Side Control Arm Shown

- b) Be sure to use the correct bolts to mount the control arms. The short bolt (9/16-18 x 3-1/2" L) is used in the front bushing of the control arm and the long bolt (9/16-18 x 3-3/4" L) is used in the rear bushing of the control arm. Both bolts pointing forward will allow the control arms to be removed from a fully assembled frame. Use anti-seize on the threads of the bolts.

2. **Install the rack and pinion assembly.**

- a) Before the rack and pinion is installed, you can center the rack on the bench before it is installed. Mark a line along the length of the input shaft. Turn the rack all the way to one side and mark the housing where the line on the input shaft lines up. Turn the rack all the way in the other direction and count the turns in the opposite direction. Mark the housing where the line on the input shaft lines up. Turn the rack back in the opposite direction 1/2 the amount of turns so that the line on the input shaft lands in between your two marks on the housing (Figure 3).



Figure 3 - Center the Rack & Pinion

- b) When installing the rack and pinion, protect the opening in the crossmember to avoid chipping the paint as clearances are very tight in several areas. Install the rack and pinion assembly **from below the crossmember** for better clearance and easier alignment. **NOTE:** Since the rack and pinion fits tight to the crossmember this would be a good time to install your fittings before it is fully installed. You can reference Figure 18 for the location of the pressure and return ports.
- c) Rotate the rack to the rear of the front frame to install in the crossmember in the correct position.
- d) Once the rack is in place, slide the aluminum spacers in place between the rack and the front crossmember and install the bolts. Use anti-seize on the bolts and torque to 95 ft-lbs. Figure 4 shows the rack installed in the frame.

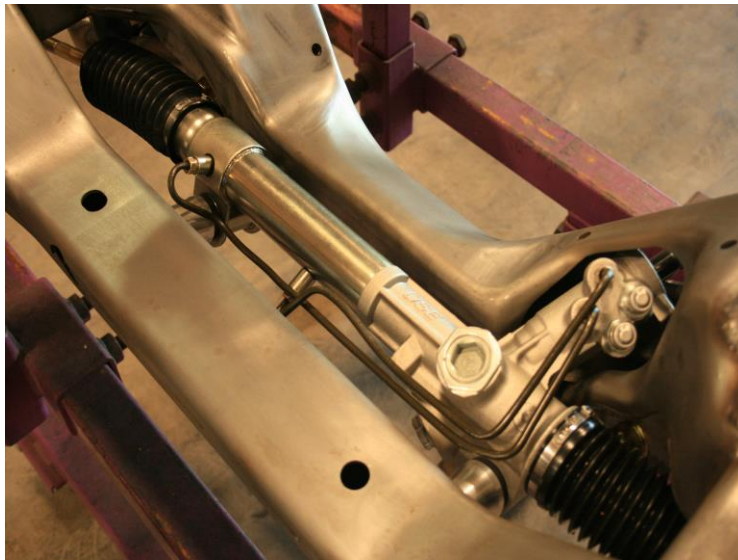

Figure 4 - Installed Rack

### 3. Install the anti-roll bar.

- a) Lube the outside of the composite bushing with soapy water. Lube the inside of the bushing and do your best to fill the interior bushing grooves with chassis grease.
- b) Before sliding the anti-roll bar in place, clean the outside of the bar thoroughly with lacquer thinner to remove any foreign materials from the bar.
- c) Once the bar is clean, slide the bar in place. After the bar is in place, install the composite bushings. The bushing may not push in completely by hand (Figure 5). Do not be concerned, as they are designed to be a very precise fit. With the bar and both bushings installed, use a large diameter socket and rubber hammer to seat the bushings on both sides at this time (Figure 6).



Figure 5 - Installing the Bushing & Anti-Roll Bar



Figure 6 - Fully Installing the Bushings

- d) After installing the bar and pushing the bushings in all the way, center the bar in the crossmember. Measure the portion protruding from the bushings on each side as in Figure 7 and adjust accordingly until this measurement is the same on both sides. Make sure to reseat the bushings against the frame before measuring, as they can shift when you move the bar and throw off your measurements.



Figure 7 - Measuring the Anti-roll Bar

- e) Install the anti-roll bar shaft clamps next. Loosen both Allen screws in the lock collar. Apply Medium Strength Loctite 242 to the threads and position the clamp onto the anti-roll bar. With the heads of the bolts accessible from the bottom, torque the bolts. **NOTE:** Be sure that the groove in the clamp is installed so that it points toward the center of the frame and the size marking is to the outside.

#### 4. Pre-assemble the Anti-roll Bar End Links to the Anti-roll Bar Arms.

- a) Fully thread the anti-roll bar end link into the threaded hole on the end of the anti-roll bar arm. **NOTE: It is critical to use High Strength Red Loctite 262 on the threads and torque.** Figure 8 shows the assembling of the anti-roll bar arm.



Figure 8 - Pre-assemble the Anti-roll Bar End Links

#### 5. Install the Anti-roll Bar Arms.

- a) Make sure both arms are positioned the same on the splines and are even in relation to one another. To determine, position the anti-roll bar arm so that it is parallel with the bottom of the framerail
- b) When both arms are parallel with the bottom of the framerail, bolt them in place. The bolt will go through the arm and line up with the groove in the end of the anti-roll bar tube.
- c) Torque the anti-roll bar arm to the anti-roll bar tube retaining bolt.
- d) **DO NOT** attach the anti-roll bar end links to the lower control arms at this point. This will be done at a later step.

6. **Install the bump stops for the upper control arms.**  
a) Position the bump stops on the frame (Figure 9).



Figure 9 - Installed UCA Bump Stop

- b) Use the 3/8" - 16 Nyloc Nut and 3/8" Flatwasher and torque.

7. **Install each coilover assembly.**

- a) Before installing each coilover, it is necessary to build each assembly.  
(1) Remove the upper spring seat from the retaining ring using a rubber hammer and moving it down off the upper shock mount as seen in Figure 10.  
(2) Remove the retaining ring from upper shock mount and pass the upper spring seat over the upper shock mount as seen in Figure 11.



Figure 10 - Removing the Upper Spring Seat    Figure 11 - Upper Spring Seat & Retaining Ring

- (3) Thread the spanner nut all the way to the bottom of the coilover shock and install the Torrington bearing set (See Figure 12) on each shock by installing one thrust washer, followed by the roller bearing and then another thrust washer. Detroit Speed recommends using high pressure grease between the roller bearing and thrust washers.



Figure 12 - Torrington Bearing Set

- (4) Slide the coilover spring over the top of the upper shock mount.  
(5) Install the upper spring seat back over the top of the upper shock mount and re-install the retaining ring back onto the upper shock mount. Press the upper spring seat up onto the retaining ring so it locks in place.

The coilover assembly is now complete and ready to be installed.

- b) Make sure the upper mounting hole is clean and free of any paint, so the bolt and spacer slide into the mounting tab.
- c) Slide the 1/2" upper bolt with spacer through the eyelet and install the 1/2" Nylock nut and washer from the shock hardware bag provided. Use anti-seize on the bolts.
- d) Position the lower coilover mount to the lower control arm. Install the lower retaining bolts from the top side of the control arm (Figure 13). **NOTE:** For the double adjustable remote canister shock upgrade, make sure that the canister hose is facing towards the lower ball joint. Failure to do this will cause permanent damage to the canister hose during suspension travel as the lower control arm gusset has been notched in this location for this option.



Figure 13 - Lower Shock Retaining Bolts

- e) Torque all coilover hardware. Figure 14 shows a completed and installed coilover spring.

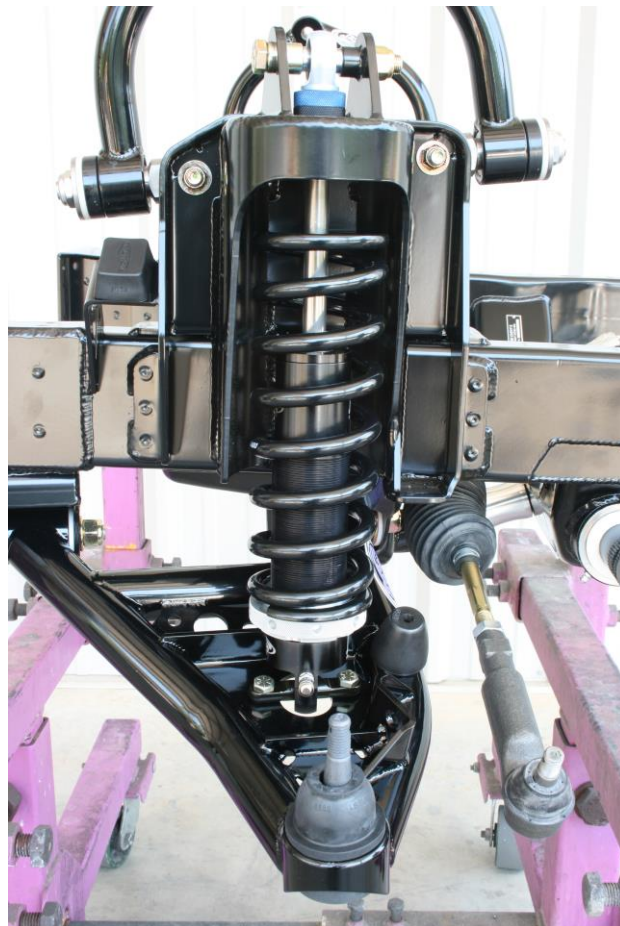

Figure 14 - Installed Coilover View

8. **Attach the sway bar arm end links to the lower control arm.**
  - a) Insert the sway bar end link into the mounting bracket on the lower control arm on either the driver or passenger side. Install the nut and loosely tighten.
  - b) On the opposite side, push up on the lower control arm and insert the sway bar end link in the bracket on the lower control arm. Use High Strength Red Loctite 262 on the threads of the end links.
  - c) With both sides installed, torque the nuts on the end links.
  
9. **Install the upper control arm assemblies.**
  - a) Obtain the proper Driver or Passenger side Upper Control Arm. Refer to Figure 15 to help determine.
  - b) Apply High Strength Red Loctite 262 to the threads of the bolts before installing nuts. Be sure to install a flat washer on both the head and nut side of the bolt.
  - c) Once the nuts have been installed, insert two shims on each bolt and torque the bolts. An installed view is shown in Figure 16.

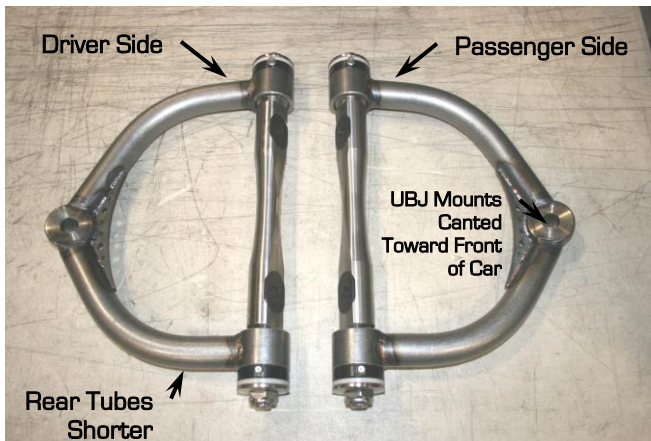

Figure 15 - Driver & Passenger Upper Control Arms



Figure 16 - Installed Upper Control Arm

10. **Install the outer tie rod ends.**
  - a) Apply anti-seize to the tie rod end threads, then thread the outer tie rod ends onto the rack and pinion.
  - b) When installing the tie rod ends, make sure they are equal distance on each side to center the steering. To verify, measure from the end of the threads to the edge of the jam nut. This measurement should be approximately 3/4" per side.
  - c) Install the grease fittings into the tie rod ends.
  
11. **Install the Detroit Speed spindle assembly.**
  - a) Clean any grease from the upper and lower ball joint studs and the spindle holes with a clean rag and lacquer thinner.
  - b) Install the spindle to the upper control arm first.
  - c) Tighten the upper ball joint flanged lock nut to 40 ft-lbs.
  - d) Place the spindle on the lower ball joint.
  - e) Tighten the lower ball joint flanged lock nut to 20 ft-lbs. plus 180° clockwise. **NOTE: It is critical to follow the torque procedure listed in the table on page 3 and to use High Strength Red Loctite 262 on the lower ball joint threads.**
  - f) Insert the outer tie rod end into the steer arm. **NOTE: Turn and position the stud so the cotter pin locates from front to rear to ease installation. Torque to 35 ft-lbs. and install the cotter pin.**
  
12. The suspension is assembled at this point. Figure 17 on the next page shows a completed installation. Double check to ensure that all installed components are tight and torqued correctly.



Figure 17 - Fully Assembled View (Driver Side)

13. **Attach the frame to the body.**

- a) Support the front frame assembly on a floor jack.
- b) Using the provided 7/16"–14 x 1-1/2" Grade 8 Hex Head Bolt and 7/16"–14 Nylock Nut along with two 7/16" Flat washers per bolt, attach the frame to the body. Use anti-seize on the bolts. **NOTE:** Insert the bolt from the engine side of the body.
- c) Tighten the hardware at this point. It is not necessary to torque at this time.
- d) Locate the driver and passenger side bay bars and install. Install the 3/8"–16 x 1" L bolts along with a 3/8" AN Flat washer at the frame rail and 3/8"–16 x 1-1/4" L bolts with a 3/8" Flat washer at the firewall. Again, tighten this hardware but it is not necessary to torque at this time.

14. **Align the front frame to the body.**

- a) Place the core support, front fenders and hood on the vehicle. Position shims as necessary between the frame and/or downbars to adjust the alignment of the front sheetmetal.
- b) With the front sheetmetal positioned on the car, torque the front frame to firewall bolts and the downbars to firewall and framerail bolts at this point.

15. After the frame is installed into the vehicle, the power steering hoses can be attached to the steering gear. Follow Figure 18 for the location of the pressure and return ports.

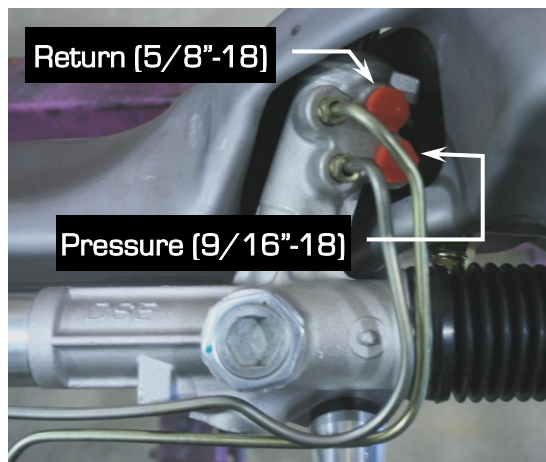

Figure 18 - Pressure and Return Port Locations

16. The front frame is now assembled and installed. **NOTE:** Be sure to lubricate all points on the front frame with quality chassis grease.

17. **Setting the vehicle ride height.**

- a) With the vehicle assembled with all components installed, adjust the vehicle ride height. Before adjusting the ride height, Detroit Speed recommends cleaning the threads of the shock. Once the threads are clean, Detroit Speed recommends applying dry bicycle chain lube to the threads of the shock body before adjusting the spanner nut and compressing the coilover spring. Allow the chain lube to dry before adjusting the spanner nut. If you have the non-adjustable shocks, the spanner nut has a soft tip set screw that will need to be tightened before the vehicle is driven.
- b) Detroit Speed does include a Spanner Tool (P/N: 031060DS) to adjust ride height however if you have the adjustable coilover shocks, Detroit Speed does offer an Adjustment Tool available as P/N: 031061DS if needed. A photo can be seen in Fig. 19.



Figure 19 – Detroit Speed Spanner and Adjustment Tools

18. If the Double Adjustable coilovers or the Double Adjustable Remote Canister Coilovers were purchased as an upgrade, refer to the following information for adjustment procedures.



Thank you for your recent purchase from JRi Shocks. Your shocks were hand-assembled in Mooresville, NC by one of our experienced technicians using only the highest quality components.

**Terms and Conditions of Sale**

The JRi Shocks Terms and Conditions of Sale control the purchase of this item and can be reviewed at [www.jrishocks.com/terms](http://www.jrishocks.com/terms)

**Limited 1-Year Warranty**

Your product comes with a Limited 1-Year Warranty. In order to be eligible for service under this warranty you **MUST** complete the online warranty registration at [www.jrishocks.com/warrantyreg](http://www.jrishocks.com/warrantyreg) within 30 days from the date of purchase.

***Detroit Speed Single Adjustable Shock Applications***

To change from the recommended “Detroit Tuned” valving, adjustments can be made independently to the rebound setting. The rebound is controlled by the knob at the upper shock mount (Shock is mounted body side down). The knob rotates clockwise (+) to increase the damping and counterclockwise (-) to decrease the damping. Refer to Figure 20a on the next page.



Figure 20a – Detroit Speed Single Adjustable Shock

To return to the Detroit Speed recommended settings, turn the knob clockwise (+) to full damping. Once at full damping turn counterclockwise (-) to reach the recommended settings. Refer to Figure 20b for the rebound settings.

Rebound (Shaft Knob) ..... 15 Open (counterclockwise, -)

Figure 20b – Detroit Speed Recommended Settings

### Adjuster Operation

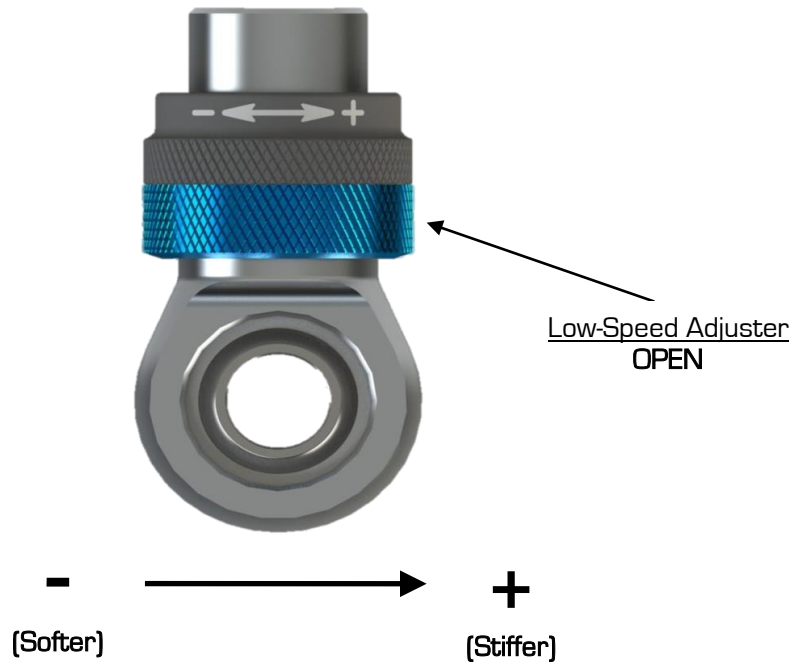

- **Adjuster (60-64 Clicks)**

The low-speed adjuster is a “clicker” style adjuster meaning that its adjustment is measured by detents located inside the blue adjuster knob. There are 16 clicks per 1 revolution of the knob. It uses a right-hand thread in its operation which means as you increase low speed, the adjuster will move up on the eyelet. The recommended change for an adjustment is 8 clicks at a time. The low-speed adjuster’s reference position is **full stiff** (closed, or all the way up) and referred to -0 (-0 = full stiff, -64 = full soft).

- **Tuning Notes**
  - **Racetrack**
    - For more grip, soften the damping.
    - For increased platform control, stiffen the damping.
  - **Street**
    - For a more comfortable ride, soften the damping

**\*DO NOT FORCE KNOB WHEN IT STOPS TURNING, YOU MAY DAMAGE THE ADJUSTER AND INTERNAL HARDWARE**

***Detroit Speed Double Adjustable Shock Applications***

To change from the recommended “Detroit Tuned” valving, adjustments can be made independently to both the high and low speed settings. The rebound is controlled by the sweepers at the upper shock mount. The sweepers rotate clockwise (+) to increase the damping and counterclockwise (-) to decrease the damping. The sweepers can be seen in Figure 21a



**Figure 21a - Detroit Speed Double Adjustable Shocks**

When adjusting the low speed rebound start at full (+) position, when adjusting the high speed rebound start at full (-) position. To return to the Detroit Speed recommended settings turn the sweeper clockwise (+) to full damping for the low-speed setting, and counterclockwise (-) to full damping for the high-speed setting. Once at full damping, turn counterclockwise (-) for the low-speed setting, and clockwise (+) for the high-speed setting to reach the recommended settings. Refer to Figure 21b for recommended settings.

Low Speed Rebound [Sweeper]..... 20 sweeps [counterclockwise] (-)  
 High Speed Rebound [Sweeper]..... 2 sweeps [clockwise] (+)

**Figure 21b - Detroit Speed Recommended Settings**

***Detroit Speed Double Adjustable Shocks w/Remote Canisters***

To change from the recommended “Detroit Tuned” valving, adjustments can be made independently to both the high and low speed settings. The rebound is controlled by the sweepers at the upper shock mount. The sweepers rotate clockwise (+) to increase the damping and counterclockwise (-) to decrease the damping. Refer to Fig. 22a on the next page.

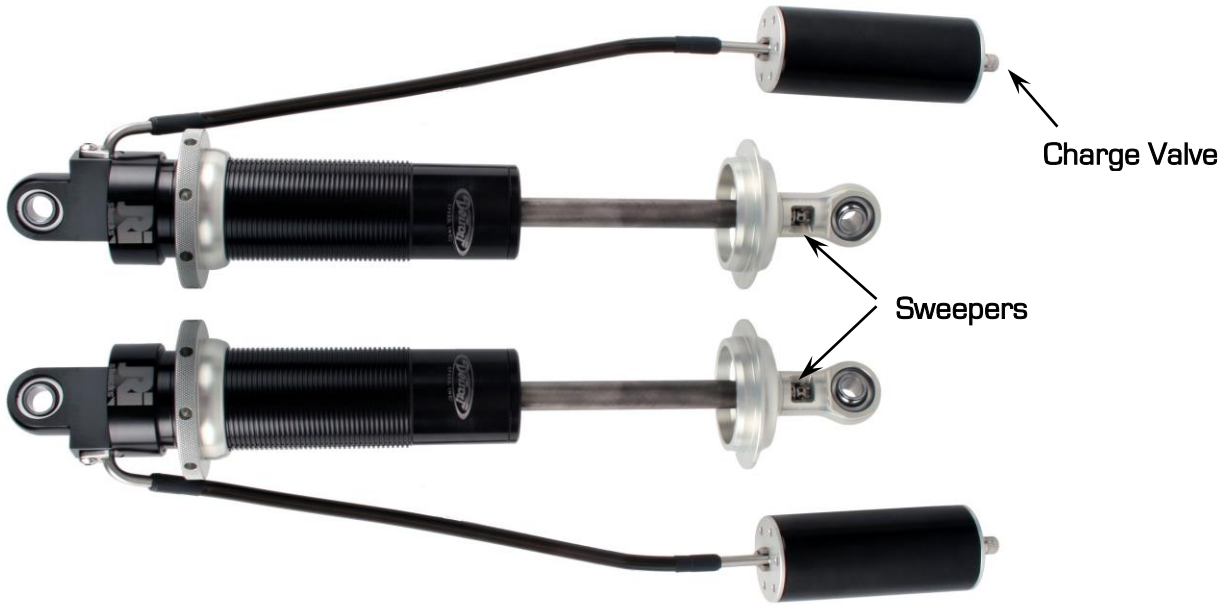

Figure 22a - Detroit Speed Double Adjustable Shock W/Remote canisters

When adjusting the low speed rebound start at full (+) position, when adjusting the high speed rebound start at full (-) position. To return to the Detroit Speed recommended settings turn the sweeper clockwise (+) to full damping for the low-speed setting, and counterclockwise (-) to full damping for the high-speed setting. Once at full damping, turn counterclockwise (-) for the low-speed setting, and clockwise (+) for the high-speed setting to reach the recommended settings. Refer to Figure 22b for recommended settings.

Low Speed Rebound [Sweeper]..... 20 sweeps [counterclockwise] (-)  
 High Speed Rebound [Sweeper]..... 2 sweeps [clockwise] (+)

Figure 22b - Detroit Speed Recommended Settings

**Adjuster Operation**

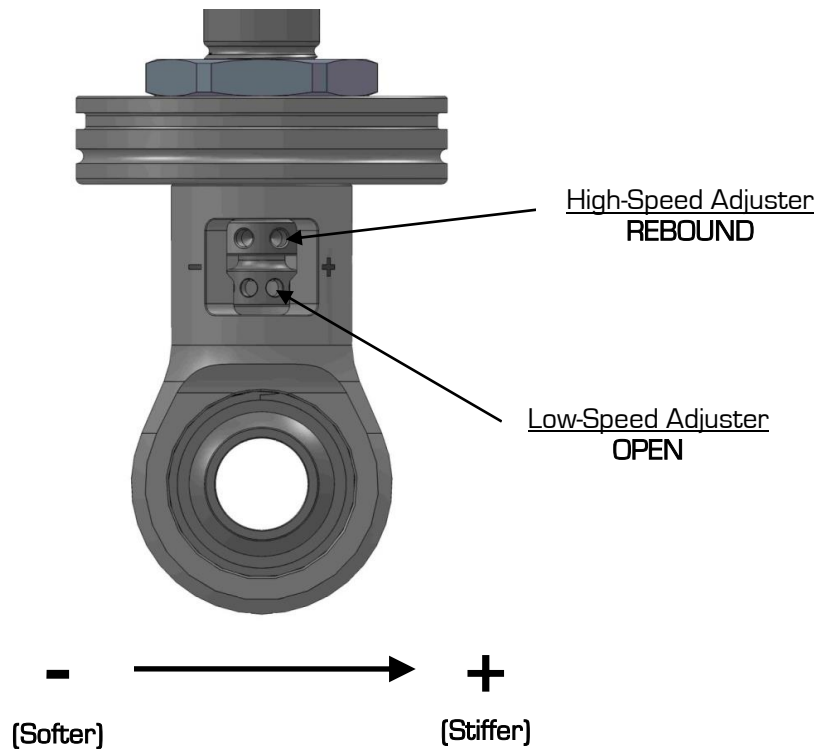

- **High-Speed Adjuster (12 Sweeps)**

The high-speed adjuster is a “sweep” style adjuster meaning that its adjustment is measured by the location of the adjuster in the eyelet window. It uses a left-hand thread in its operation which means; as you increase high-speed, the adjuster will move down in the window\*. The high-speed adjuster’s reference position is **full soft** and referred to as +0 (+0 = full soft, +12 = full stiff).

- **Low-Speed Adjuster (25 Clicks)**

The low-speed adjuster is a “clicker” style adjuster meaning that its adjustment is measured by detent grooves located inside the high-speed shaft. It uses a right-hand thread in its operation which means; as you increase low speed, the adjuster will move up in the window. The low-speed adjuster’s reference position is **full stiff** and referred to -0 (-0 = full stiff, -25 = full soft).

*\*The low-speed adjustment does not change when adjusting the high-speed.*

To aid in the installation of the reservoirs, we also offer a set of Billet Aluminum Remote Canister Mounts. The canister mounts are available exclusively through Detroit Speed, P/N: 032102DS. They are shown in Figure 23.



**Figure 23 – Billet Aluminum Remote Canister Mounts**

19. Have a professional alignment completed following the specifications given in the chart on Pg. 2.

If you have any questions before or during the installation of this product, please contact Detroit Speed at [sales@detroitsspeed.com](mailto:sales@detroitsspeed.com) or 704.662.3272

**Legal Disclaimer:** *Detroit Speed is not liable for personal, property, legal, or financial damages from the use or misuse of any product we sell. The purchaser is solely responsible for the safety and performance of these products. No warranty is expressed or implied.*

# **BORGESON**

## ***Steering You Forward***

91 Technology Park Dr.  
Torrington, CT 06790  
Phone: 860-482-8283  
Fax: 860-496-9320

### **WANTED!!**

#### 1962-1967 Chevy II Used Steering Boxes

Borgeson will give you up to \$50.00 for your used steering box.

If you have any questions concerning this offer, please contact Borgeson at (860) 482-8283 or email Borgeson at [sales@borgeson.com](mailto:sales@borgeson.com). Freight is to be paid by the shipper and COD's will not be accepted. Prices are subject to change. For the most current pricing, go to [www.borgeson.com](http://www.borgeson.com).

Check is to be sent to:

Name: \_\_\_\_\_

Street address/P.O. Box: \_\_\_\_\_

City, State and Zip Code: \_\_\_\_\_

Telephone Number: \_\_\_\_\_

Steering gear application: \_\_\_\_\_

Please ship the steering box and the completed form to:

Borgeson Universal Co., Inc.  
Attn: Core Department  
91 Technology Park Drive  
Torrington, CT 06790

**\*\*\*\*\*DO NOT ship the gear box to Detroit Speed\*\*\*\*\***