



DON'T FORGET

These instructions can be found in color and expandable at QA1.net

Technical Support Line: (952) 985-5675 Email: sales@QA1.net

INSTALLATION INSTRUCTIONS

QA1 P/N 52853 '78-'88 GM G-Body Rear Anti-Roll Bar

QA1 P/N 52865 '64-'67 GM A-Body Rear Anti-Roll Bar

QA1 P/N 52857 '68-'77 GM A-Body Rear Anti-Roll Bar

TOOLS AND SUPPLIES REQUIRED

- Floor Jack
- Jack Stands
- Ratchet & Socket Set
- Torque Wrench

PRE-INSTALLATION NOTES-

Some exhaust systems will need to be re-routed for bar clearance. Be sure to check exhaust to bar clearance at ride height.

REMOVAL-

1. Raise and support the vehicle with jack stands on a level surface.
2. Remove the factory sway bar mounting hardware and remove the sway bar (if equipped).



INSTALLATION-

1. Loosely mount the anti-roll bar to the axle using the included u-bolt kit and bar bushing clamps. A small amount of the included grease on the inner bushings where the bar will contact is recommended. The legs of the bar should be pointing towards the front of the vehicle and the rear of the bar biased downward. **(Figure 1-3)** Leave the u-bolt connection loose until the bar is fully installed so the angle of the mount can be adjusted.



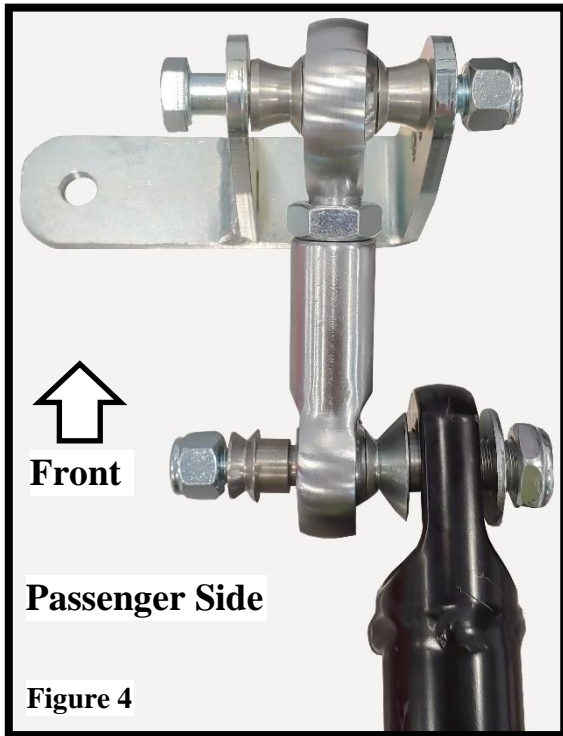
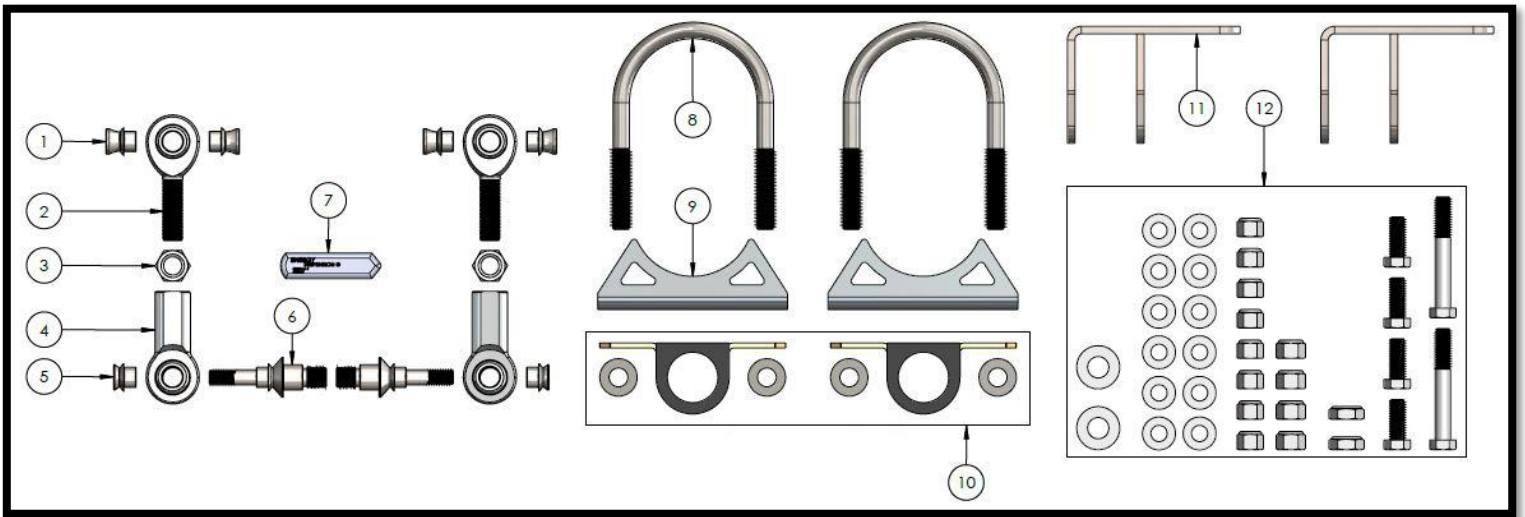

Figure 4

BALLOON #	ITEM #	DESCRIPTION	QTY.
1	SG8-67	HIGH MISALIGNMENT SPACER, SS	4
2	XMR8	ROD END (X) ENDURA ALLOY HT	2
3	JNR8S	JAM NUT, STEEL 1/2-20 RH	2
4	XFR8	ROD END (X) ENDURA ALLOY HT	2
5	SG8-64	HIGH MISALIGNMENT SPACER, .5" OD	2
6	9029-309	HIGH MISALIGNMENT STUD	2
7	9071-109	TUBE, TEFLON LUBE (POLY BUSHING LUBE)	1
8	9012-204	U-BOLT, 7/16-20 X 3.125" X 4.5"	2
9	9037-628	BRACKET, AXLE SADDLE MOUNT, 3 INCH	2
10	9032-171	BUSHING, SWAY BAR FRAME MOUNT 1-1/4"	1
11	9037-1015	WELDMENT, SWAY BAR MOUNT	2
12	7039-319	HARDWARE KIT, REAR SWAY BAR, 52851	1

2. Thread one jam nut onto the male rod end before threading into the female rod end.

3. Insert the large diameter end of the high misalignment stud into the bar end with the bar on the outboard side of the assembly, followed by one 1/2" washer and 1/2" nyloc nut. **(Figure 4, lower joint)**

4. Insert one high misalignment spacer onto the stud followed by one 3/8" nyloc nut. Torque to 31 lb. ft.
5. Insert one SG8-67 high misalignment spacer into each end of the bore of the opposite rod end before attaching the rod end into the bracket.
6. Attach the rod end to the bracket using one 3/8" x 2-3/4" bolt and one 3/8" nyloc nut. Torque to 31 lb. ft.

NOTE-

The frame brackets will be mounted to the upper trailing arm crossmember. The brackets can be installed facing inboard or outboard depending on the clearances needed, but the rod end must be inboard of the sway bar. **(Figure 5)** Exhaust routing could interfere with the bar mounting and the bracket position should be adjusted as needed.

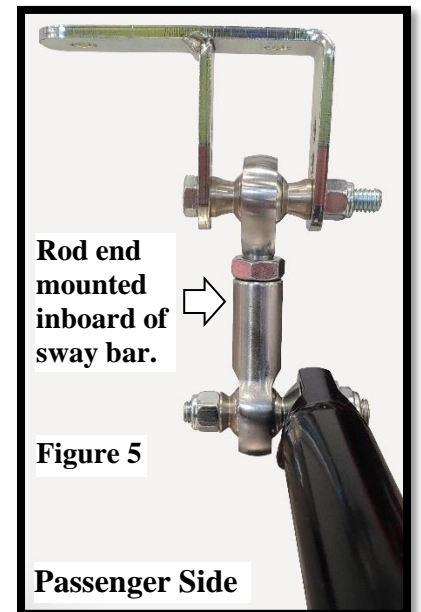

Figure 5

Passenger Side

7. With the bar centered to the vehicle, swing the legs of the bar up to the upper trailing arm crossmember. Mark both bracket holes onto the crossmember before drilling them to 3/8".
8. Install the brackets to the crossmember using 3/8" x 1" bolts, with two washers and one nyloc nut per connection. **(Figure 6)** Torque to 31 lb. ft.
9. With the vehicle at ride height, rotate the axle u-bolts as needed to allow the end link to be as vertical as possible. When complete, torque the u-bolt connections to 50 lb. ft.
10. Double check all bar clearances at ride height before driving.



Figure 6

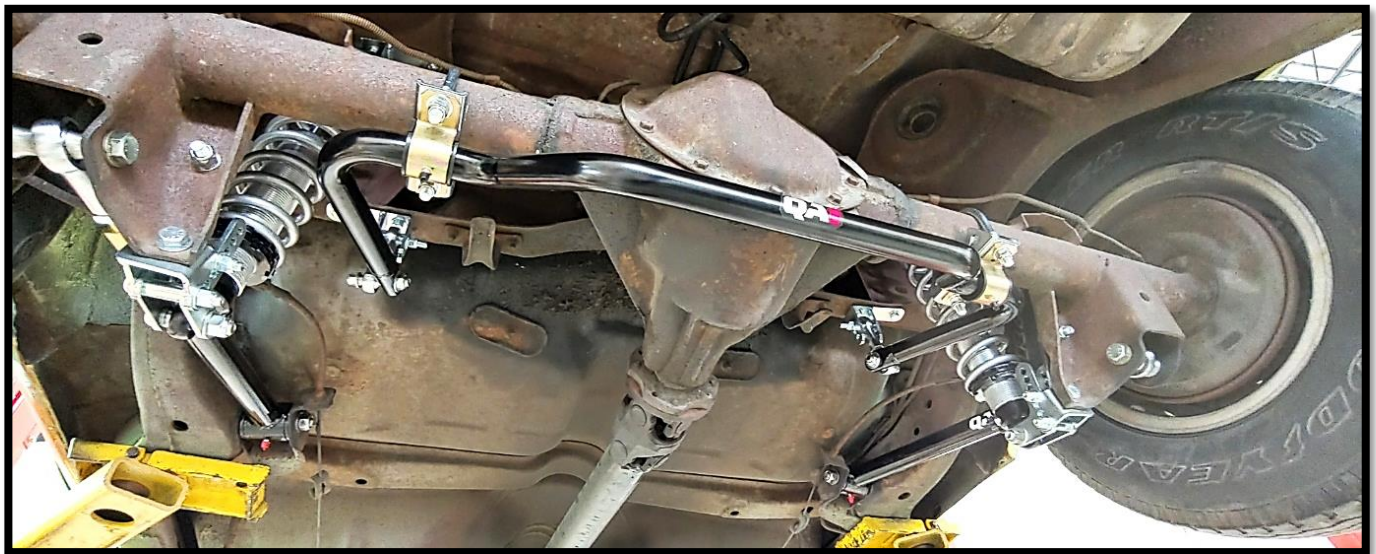

DEDICATED TECH SUPPORT

QA1 is dedicated to providing quality support and instructions. We employ passionate racers and car enthusiasts that know our products and the industry to better serve you.

CHECK US OUT ON YOUTUBE!



- Frequently Asked Questions
- Quick Tips
- Install Information
- Tuning and Repair Guides
- Other Technical Information



- [linkedin.com/company/qa1](https://www.linkedin.com/company/qa1)
- [instagram.com/qa1motorsports](https://www.instagram.com/qa1motorsports)
- [facebook.com/qa1motorsports](https://www.facebook.com/qa1motorsports)

www.qa1.net/tech



Technical Support Line: (952) 985-5675 Email: sales@QA1.net

READ ALL INSTRUCTIONS CAREFULLY AND THOROUGHLY PRIOR TO STARTING INSTALLATION. PRODUCTS THAT HAVE BEEN INSTALLED ARE NOT ELIGIBLE FOR RETURN. USE THE PROPER JACKING LOCATIONS. DEATH OR SERIOUS INJURY CAN RESULT IF INSTRUCTIONS ARE NOT CORRECTLY FOLLOWED. A GOOD CHASSIS MANUAL, AVAILABLE AT YOUR LOCAL PARTS STORE, MAY ALSO AID IN YOUR INSTALLATION.

• **DISCLAIMER / WARRANTY** •

QA1 WARRANTS THAT THE PRODUCTS WILL BE FREE FROM DEFECTS IN MATERIAL AND WORKMANSHIP FOR ONE YEAR FROM DATE OF SALE TO THE ORIGINAL PURCHASER. QA1 MAKES NO OTHER WARRANTY OF ANY KIND, EXPRESS OR IMPLIED. QA1 SHALL HAVE NO OBLIGATION UNDER THE FOREGOING WARRANTY WHERE THE DEFECT IS THE RESULT OF IMPROPER OR ABNORMAL USE, YOUR NEGLIGENCE, VEHICLE ACCIDENT, IMPROPER OR INCORRECT INSTALLATION OR MAINTENANCE, NOR WHEN THE PRODUCT HAS BEEN REPAIRED OR ALTERED IN ANY WAY. QA1'S LIABILITY IN THE CASE OF DEFECTIVE PRODUCTS SUBJECT TO THE FOREGOING WARRANTY SHALL BE LIMITED TO THE REPAIR OR REPLACEMENT, AT QA1'S OPTION, OF THE DEFECTIVE PRODUCTS.

THE USER UNDERSTANDS AND RECOGNIZES THAT RACING PARTS, SPECIALIZED STREET ROD EQUIPMENT, AND ALL PARTS AND SERVICES SOLD BY QA1 ARE EXPOSED TO MANY AND VARIED CONDITIONS DUE TO THE MANNER IN WHICH THEY ARE INSTALLED AND USED. QA1 SHALL BEAR NO LIABILITY FOR ANY LOSS, DAMAGE OR INJURY, EITHER TO A PERSON OR TO PROPERTY, RESULTING FROM THE INSTALLATION, DIRECT OR INDIRECT USE OF ANY QA1 PRODUCTS OR INABILITY BY THE BUYER TO DETERMINE PROPER USE OR APPLICATION OF QA1 PRODUCTS. WITH THE EXCEPTION OF THE LIMITED LIABILITY WARRANTY SET FORTH ABOVE, QA1 SHALL NOT BE LIABLE FOR ANY CLAIMS, DEMANDS, INJURIES, DAMAGES, ACTIONS, OR CAUSES OF ACTION WHATSOEVER TO BUYER ARISING OUT OF OR CONNECTED WITH THE USE OF ANY QA1 PRODUCTS. MOTORSPORTS ARE DANGEROUS; AS SUCH, NO WARRANTY OR REPRESENTATION IS MADE AS TO THE PRODUCT'S ABILITY TO PROTECT THE USER FROM INJURY OR DEATH. THE USER ASSUMES THAT RISK!