



These instructions can be found in color and expandable at QA1.net

Technical Support Line: (952) 985-5675 Email: sales@QA1.net

INSTALLATION INSTRUCTIONS

QA1 P/N MS618-14500, MD618-14500 (2WD)
MS718-12700, MD718-12700 (4WD)
'15-'20 F150 Front Pro Coil System

TOOLS AND SUPPLIES REQUIRED

- Floor Jack
- Two (2) Jack Stands
- SAE Wrench Set
- Ratchet & Metric Socket Set
- Torque Wrench
- Anti-seize
- Dremel or Die Grinder

PRE INSTALLATION NOTES:

The ride height range for this coil-over is 1"-3" lower than stock with the factory spindle and 3"- 5" lower with a drop spindle.

The following note only applies if using drop spindles with this suspension.

- Drop spindles will require 22" aftermarket rims or larger with 6" backspacing or less.
- Most factory 20" wheels will fit. Must check lower ball joint stud clearance with the inner wheel.
- Lower ball joint stud may need to be shortened. (photo below)
- Factory 22" wheels will not fit.

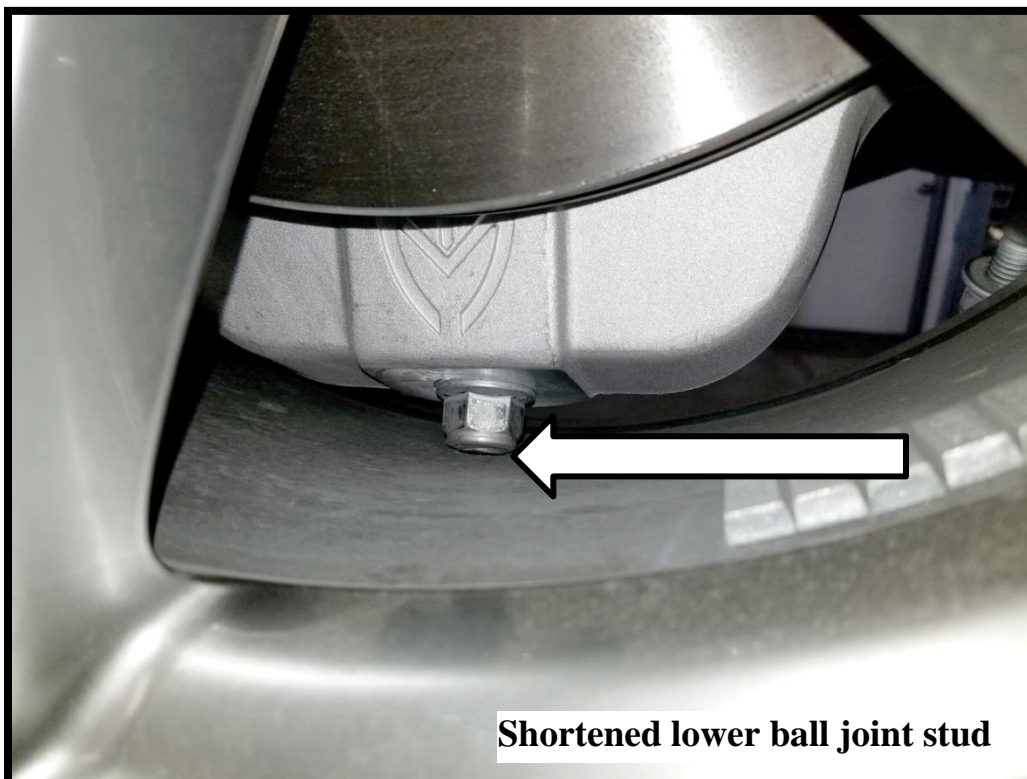

DISASSEMBLY INSTRUCTIONS

- 1) Measure the vehicle ride height from the ground to the lip of the fender through the center of the wheel as a record of the original ride height.
- 2) With the parking brake set, raise and support the front of the vehicle by the frame with jack stands on a stable surface and remove the front wheels. Refer to the manufacturers recommended jacking points in the owners' manual.
- 3) Remove the ABS and brake line bracket from the spindle and frame using 8mm and 10mm sockets. **(Figure 1)**
- 4) Remove the tie rods from both spindles using a 21mm socket or wrench.
- 5) Remove the sway bar end link nuts using an 8mm and 19mm wrench.
- 6) Using 21mm and 11/16" wrenches, loosen the mounting bolts of the lower control arm to allow more movement of the arm. DO NOT REMOVE THE MOUNTING HARDWARE AT THIS TIME.

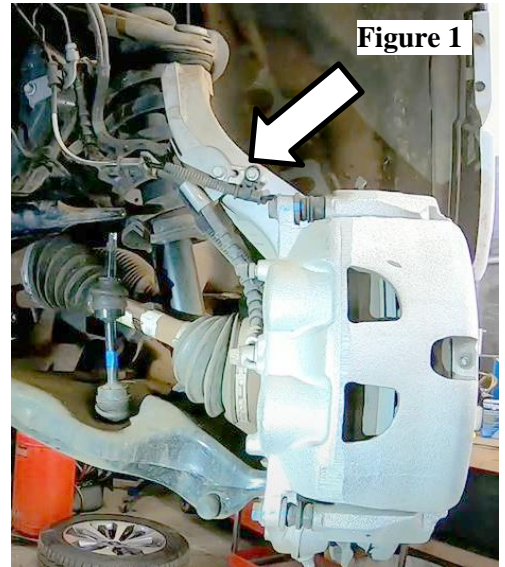

- 7) Loosen the lower ball joint castle nut leaving the nut on the stud. DO NOT FULLY REMOVE AT THIS TIME.
- 8) With the castle nut still on the lower ball joint stud, unseat the lower ball joint stud from the spindle by tapping the spindle with a hammer.
- 9) Support the lower control arm with a floor jack to contain the spring pressure before removing the lower ball joint castle nut.
- 10) Remove the three upper nuts of the upper spring plate using a 15mm socket. **(Figure 2)**

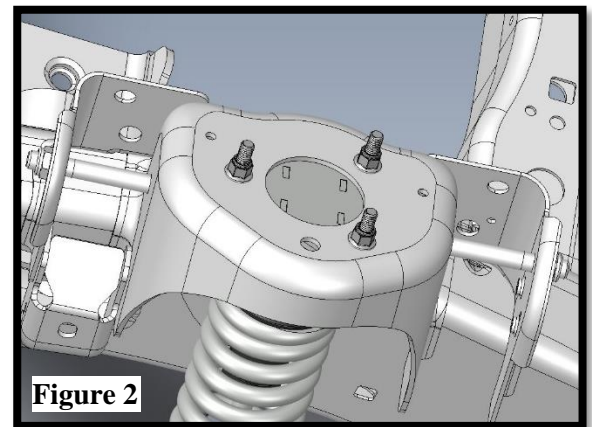

- 11) Slowly lower the floor jack supporting the lower control arm. The three upper studs should drop down from their mounting holes ensuring no further spring pressure is present.
- 12) Using an 18mm socket, remove the hardware connecting the lower strut to the lower control arm. **(Figure 3)**
- 13) Remove the strut/spring assembly from the truck.
- 14) Fully remove the lower control arm hardware and remove the arm from the truck.

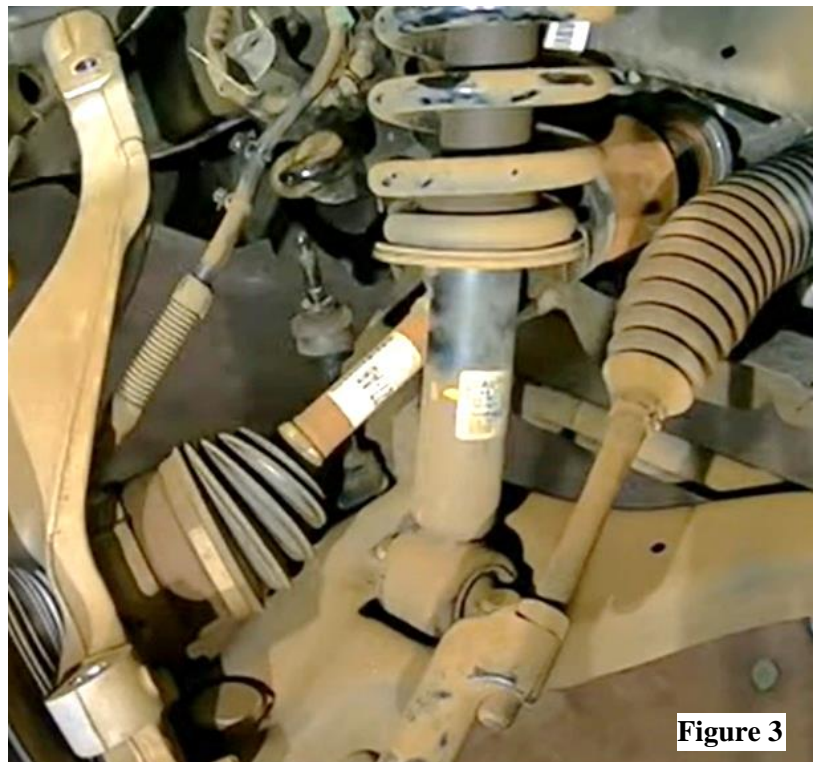

15) If lowering the truck more than 1.5", mark all lower control arm mounting holes 1/2" wider on the inboard side of the holes. (Figure 4)

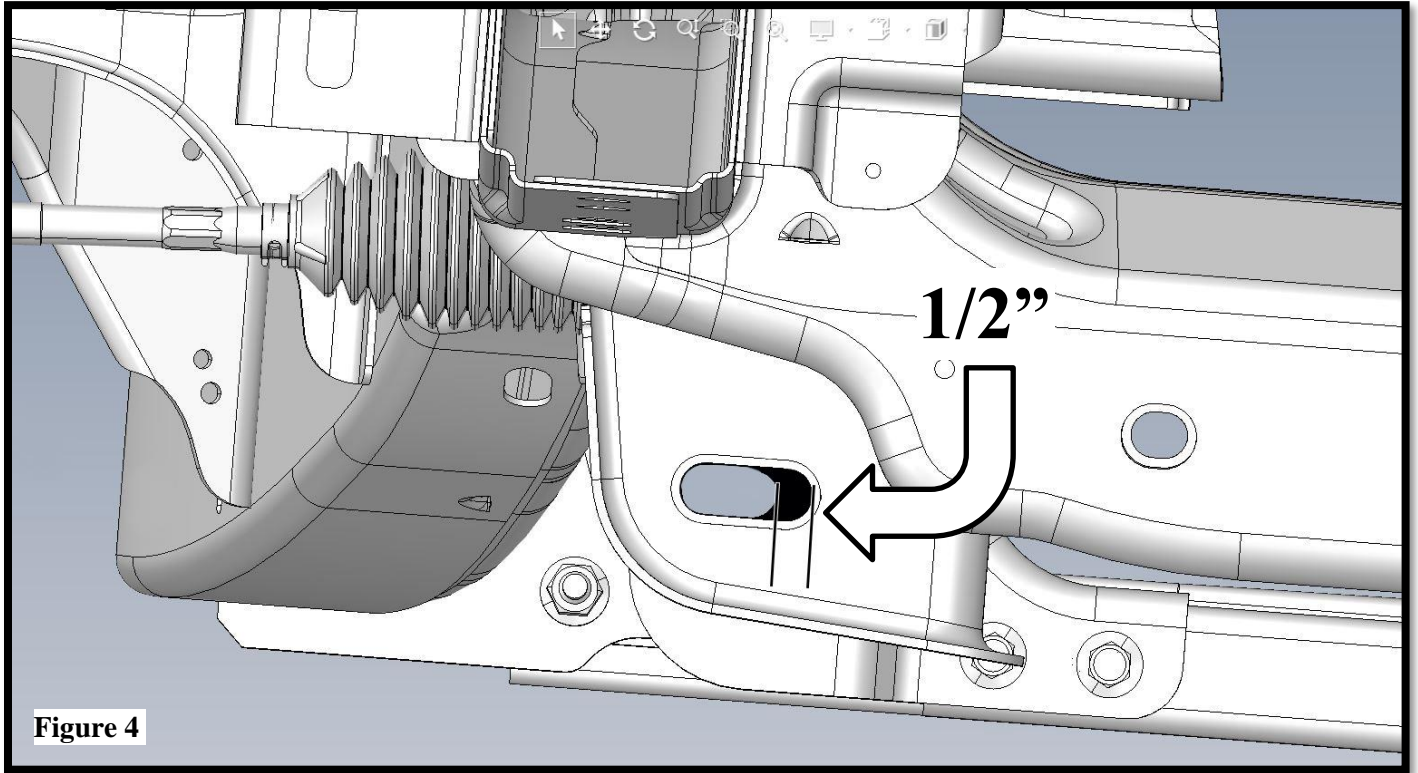

16) Using a Dremel or die grinder, open the marked mounting holes 1/2" wider inboard. Opening these mounting holes on trucks lowering more than 1.5" below stock will allow additional adjustments to re-align the truck to factory specs.

SHOCK ASSEMBLY:

NOTE-

This coil-over kit comes with rubber bump stops as well as 1/2" and 1/8" packer shims that will prevent the spring from going into coil bind.

BALLOON #	ITEM #	DESCRIPTION	QTY.
1	9047-122	BUMPER COMPRESSION 15mm ID X 1.81" OD	4
2	9004-191	SPACER, BUMP STOP, .125" TALL	2
3	9004-190	SPACER, BUMP STOP, .5" TALL	6
4	7039-341	HARDWARE KIT, FRONT COIL-OVER	1

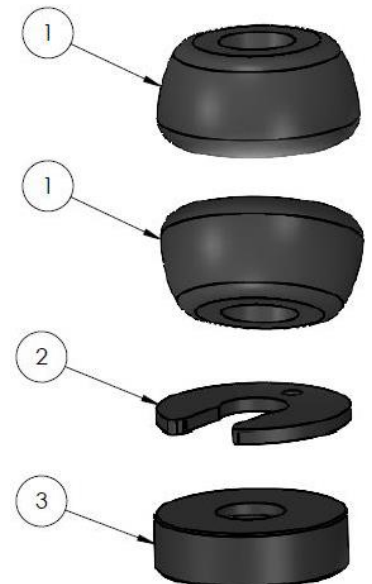

- 1) Loosen the jam nut under the upper shock eyelet and unthread the eyelet from the shock.
- 2) Remove the jam nut and small o-ring (travel indicator) from the shock rod.
- 3) With the adjustment setting(s) on the softest setting (counter-clockwise until the knob stops), pull the shock rod by hand to fully extend the shock.



- 4) Following the packer thickness recommendation for 2wd and 4wd applications, add .625" of packers to 2WD applications and 1.5" of packers for 4WD applications onto the shock rod. **(Figure 5)**
- 5) Slide two rubber bump stops (per shock) onto the shock rod above the packer shims with the larger diameters of the bump stop facing each other. Light lubrication will aid in the bump stop installation. **(Figure 6)**

Figure 5

15-20 F150 2WD			
PACKER HEIGHT CHART			
DROP RANGE	PACKER HEIGHT	1/8" PACKERS	1/2" PACKERS
1.00"-3.00"	.625"	1	1

15-20 F150 4WD			
PACKER HEIGHT CHART			
DROP RANGE	PACKER HEIGHT	1/8" PACKERS	1/2" PACKERS
1.00"-3.00"	1.50"	0	3

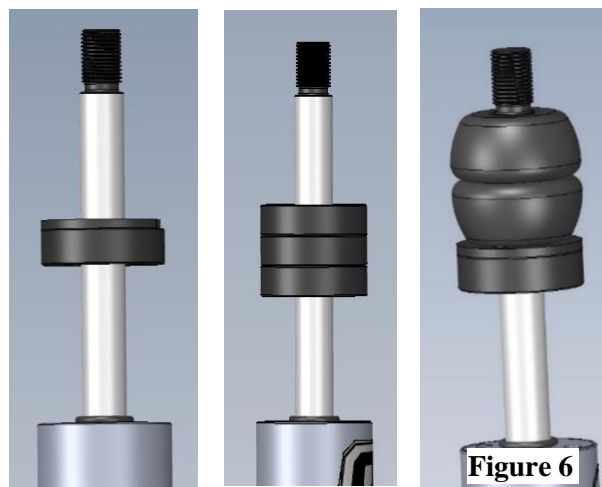

Figure 6

- 6) Lightly coat the bottom portion of the shock threads with Permatex Anti-Seize.
- 7) Thread the aluminum locking collar (shoulder up) onto the shock, followed by the spring seat collar (shoulder up) down to the bottom shock thread - NO FURTHER. **(Figure 7)**
- 8) QA1 recommends using the optional Thrust Bearing Kit (QA1 P/N 7888-109) for ease of adjustment. If the thrust bearing kit is used, coat both sides of the washers with **Permatex® Anti-Seize lubricant**. Install the stainless-steel spring seat washer, followed by the bearing and finally, the second washer. When complete, the thrust bearing kit will resemble a "needle bearing sandwich". When using the optional thrust bearing kit the stainless steel washer that came with your shock will not be needed. If the optional thrust bearing kit isn't used, the stainless washer that came with the shocks will suffice as the separator between the spring and the spring seat collar.
- 9) Install the coil spring onto the shock.

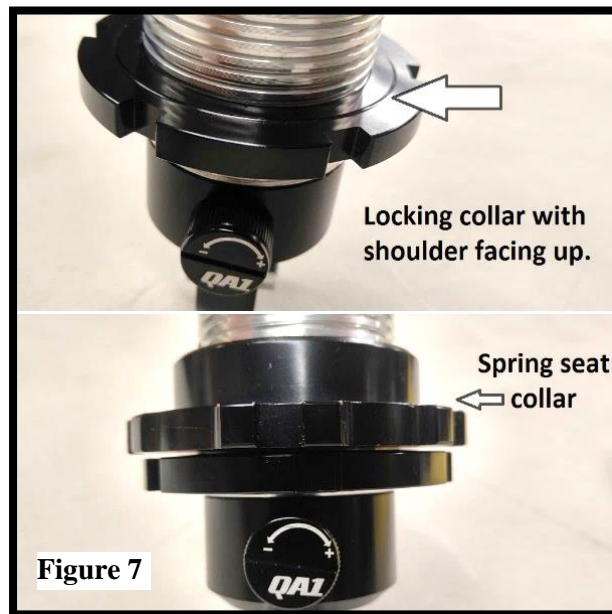

Figure 7

10) Install the upper spring cap onto the shock. **(Figure 8)**

11) Make sure any/all shock adjustment knobs are on the softest setting (counterclockwise until the knob stops).

12) Re-install the upper shock eyelet onto the shock rod and tighten the jam nut against the eyelet by hand, then tighten an additional 45 degrees. **(Figures 8 &9)**

13) Install the upper mounting plate to the upper shock eyelet using 5/8" x 3" bolt, with two washers and one nyloc nut. The upper plates are not right/left (driver/passenger) side specific. **(Figure 10)** Torque to 150 lb. ft.

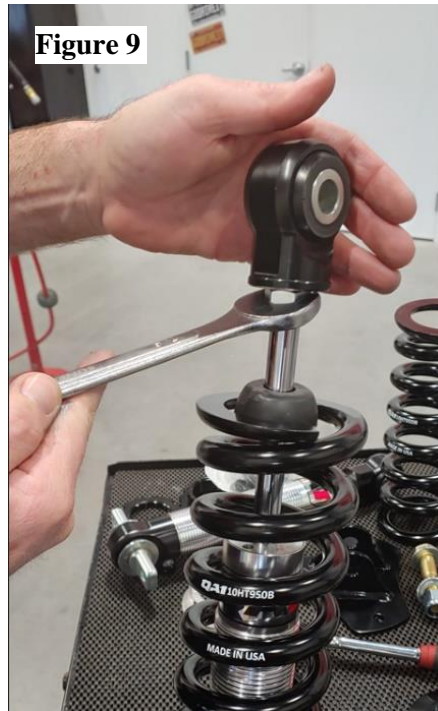

14) Install the upper mounting plate of the coil-over to the vehicle using M10-1.5 x 40mm hardware, with one M10 washer under the bolt head and one M10 flanged nut. The passenger side upper plate will fit the factory bolt holes with the "tip of the triangle" towards the rear **(Figure 11)** and the driver side plate will be opposite, with the "tip of the triangle" towards the front. Torque to 53 lb. ft.

15) Reinstall the lower control arm reusing the factory hardware.

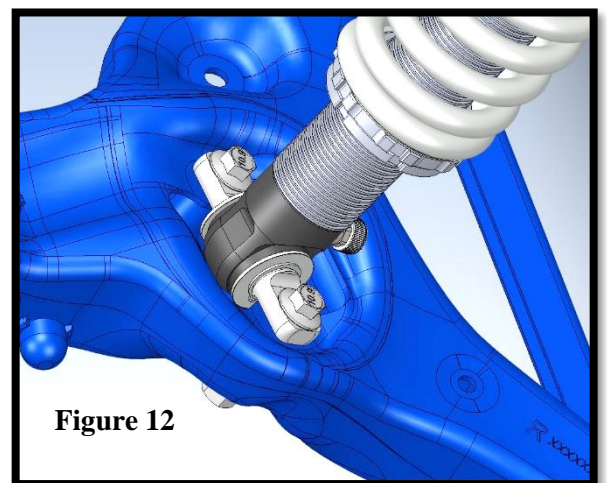
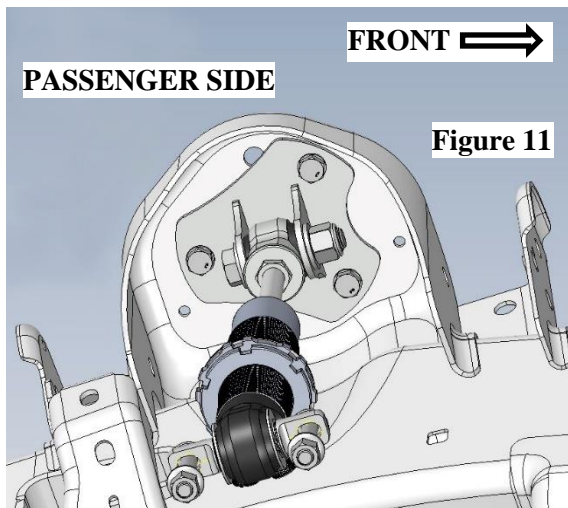

- 16) Raise the spring seat collar by hand up the shock body until the spring is not loose.
- 17) Install the lower t-bar shock mount to the lower control arm using the flanged M12 x 1.75 bolt and one nyloc nut per connection. **(Figure 12)** Torque to 93 lb. ft.
- 18) Adjust the spring seat collar up the threaded shock body to expose the correlating amount of threads per desired drop. **(Figure 13)** The adjustment collars will be close to the front axles on 4wd models but will gain clearance as the truck is set down and the suspension is compressed.
- 19) Reinstall the ABS/brake line bracket, tie rods, and sway bar end links before setting the truck on the ground to check the ride height. Make adjustments to the spring seat collars using T114W or T115W spanner wrenches. Adjustments should only be made with the weight off the front suspension. When setting the truck down to check the ride height, roll the truck back and forth to settle the suspension before measuring. A typical suspension will lower an additional 3/8" after settling. Once the desired ride height is achieved, snug the lower locking collar into the spring seat collar.

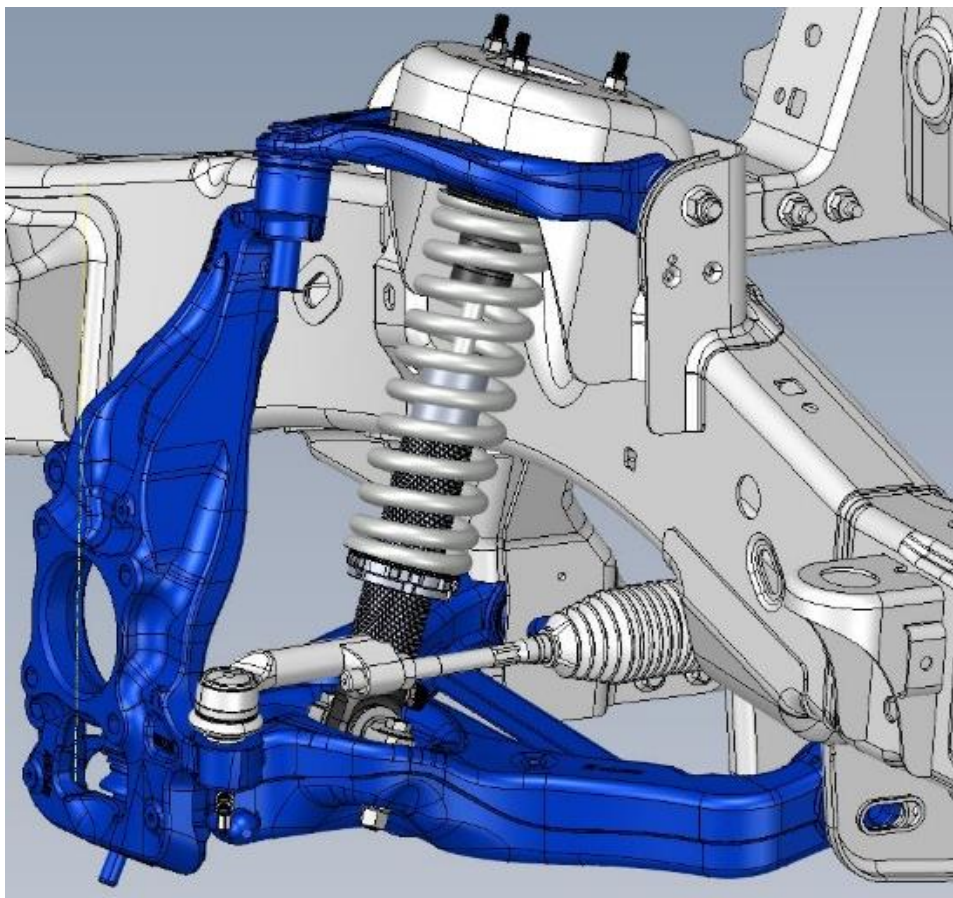

Figure 13

15-20 F150 2WD	
INITIAL INSTALL HEIGHT	
DROP	EXPOSED THREADS
3.0"	1"
2.0"	1 3/4"
1.0"	2 3/8"

15-20 F150 4WD	
INITIAL INSTALL HEIGHT	
DROP	EXPOSED THREADS
3.0"	3 1/4"
2.0"	4"
1.0"	4 5/8"

A professional four-wheel alignment is required before driving the vehicle.

Front Shock Valving Adjustments

Shocks with one adjuster knob:

Drag Racing:	0-6 clicks
Nice ride and handling:	2-6 clicks
Firm ride & improved handling:	6-12 clicks
Aggressive handling:	13-18 clicks

Shocks with two adjuster knobs:

Compression	Rebound
12-18 clicks	0-6 clicks
2-6 clicks	3-8 clicks
6-12 clicks	8-14 clicks
13+ clicks	14-18 clicks

Important Notice Regarding ADAS: This product may affect the operation of your vehicle's ADAS, such as lane departure warning systems, automatic emergency braking systems, and adaptive cruise control systems. It is the responsibility of the installer to ensure that the ADAS systems are properly recalibrated after installation. Failure to do so may result in the ADAS systems not operating as intended and could potentially lead to a collision or other safety hazards. By purchasing and installing this product, you acknowledge and accept the risks associated with modifying your vehicle's suspension and potentially affecting its ADAS systems.



Technical Support Line: (952) 985-5675 Email: sales@QA1.net

READ ALL INSTRUCTIONS CAREFULLY AND THOROUGHLY PRIOR TO STARTING INSTALLATION. PRODUCTS THAT HAVE BEEN INSTALLED ARE NOT ELIGIBLE FOR RETURN. USE THE PROPER JACKING LOCATIONS. DEATH OR SERIOUS INJURY CAN RESULT IF INSTRUCTIONS ARE NOT CORRECTLY FOLLOWED. A GOOD CHASSIS MANUAL, AVAILABLE AT YOUR LOCAL PARTS STORE, MAY ALSO AID IN YOUR INSTALLATION.

• DISCLAIMER / WARRANTY •

QA1 WARRANTS THAT THE PRODUCTS WILL BE FREE FROM DEFECTS IN MATERIAL AND WORKMANSHIP FOR ONE YEAR FROM DATE OF SALE TO THE ORIGINAL PURCHASER. QA1 MAKES NO OTHER WARRANTY OF ANY KIND, EXPRESS OR IMPLIED. QA1 SHALL HAVE NO OBLIGATION UNDER THE FOREGOING WARRANTY WHERE THE DEFECT IS THE RESULT OF IMPROPER OR ABNORMAL USE, YOUR NEGLIGENCE, VEHICLE ACCIDENT, IMPROPER OR INCORRECT INSTALLATION OR MAINTENANCE, NOR WHEN THE PRODUCT HAS BEEN REPAIRED OR ALTERED IN ANY WAY. QA1'S LIABILITY IN THE CASE OF DEFECTIVE PRODUCTS SUBJECT TO THE FOREGOING WARRANTY SHALL BE LIMITED TO THE REPAIR OR REPLACEMENT, AT QA1'S OPTION, OF THE DEFECTIVE PRODUCTS.

THE USER UNDERSTANDS AND RECOGNIZES THAT RACING PARTS, SPECIALIZED STREET ROD EQUIPMENT, AND ALL PARTS AND SERVICES SOLD BY QA1 ARE EXPOSED TO MANY AND VARIED CONDITIONS DUE TO THE MANNER IN WHICH THEY ARE INSTALLED AND USED. QA1 SHALL BEAR NO LIABILITY FOR ANY LOSS, DAMAGE OR INJURY, EITHER TO A PERSON OR TO PROPERTY, RESULTING FROM THE INSTALLATION, DIRECT OR INDIRECT USE OF ANY QA1 PRODUCTS OR INABILITY BY THE BUYER TO DETERMINE PROPER USE OR APPLICATION OF QA1 PRODUCTS. WITH THE EXCEPTION OF THE LIMITED LIABILITY WARRANTY SET FORTH ABOVE, QA1 SHALL NOT BE LIABLE FOR ANY CLAIMS, DEMANDS, INJURIES, DAMAGES, ACTIONS, OR CAUSES OF ACTION WHATSOEVER TO BUYER ARISING OUT OF OR CONNECTED WITH THE USE OF ANY QA1 PRODUCTS. MOTORSPORTS ARE DANGEROUS; AS SUCH, NO WARRANTY OR REPRESENTATION IS MADE AS TO THE PRODUCT'S ABILITY TO PROTECT THE USER FROM INJURY OR DEATH. THE USER ASSUMES THAT RISK!

DEDICATED TECH SUPPORT

QA1 is dedicated to providing quality support and instructions. We employ passionate racers and car enthusiasts that know our products and the industry to better serve you.

CHECK US OUT ON YOUTUBE!



- Frequently Asked Questions
- Quick Tips
- Install Information
- Tuning and Repair Guides
- Other Technical Information



- [linkedin.com/company/qa1](https://www.linkedin.com/company/qa1)
- [instagram.com/qa1motorsports](https://www.instagram.com/qa1motorsports)
- [facebook.com/qa1motorsports](https://www.facebook.com/qa1motorsports)

[youtube.com/qa1tech](https://www.youtube.com/qa1tech)

9919-302

7

www.qa1.net/tech

Rev. 03122024