



**DON'T FORGET**  
These instructions can be found in  
color and expandable at QA1.net

Technical Support Line: (952) 985-5675 Email: sales@QA1.net

### INSTALLATION INSTRUCTIONS

QA1 P/N 52850

'71-'76 GM B-Body Front Sway Bar

### TOOLS AND SUPPLIES REQUIRED

- Floor Jack
- Jack Stands
- Ratchet & Socket Set
- Torque Wrench

### Removal

1. Raise and support the vehicle with jack stands on a level surface.
2. Remove the sway bar end links from the sway bar. It may be necessary to hold the stud with a wrench while removing the nut.
3. Unbolt the swaybar bushing mounting clamps from the frame.
4. The sway bar can now be removed from the vehicle.

### Installation

1. Install the included frame brackets to the existing frame holes with the brackets biased towards the front of the vehicle using 3/8" x 1" thin head bolts. Torque to 31 lb. ft. **(Figure 1)**
2. Apply a small amount of red loctite to the 1-1/4" studs and thread them into the frame brackets as shown, finger tight.
3. Apply the supplied grease liberally on the supplied sway bar bushings. Install the bushings on the sway bar then using the clamps from the kit, mount the sway bar to the frame brackets with the legs of the sway bar on the top side of the lower control arms. Secure the bar clamps to the bracket with one 3/8" washer and nyloc nut per connection. Torque to 31 lb. ft. **Figure 2.**
4. Compress the suspension by setting the vehicle on the ground before connecting the sway bar end links to the control arm. The new end link bushings having never been compressed and can make the bolt appear to be too short. Further compression of the sway bar to control arm may be necessary to get the end link nut started.
5. Install the supplied end link kits the same way the OEM links were installed. Torque the end link bolts to 10-18 lb. ft. Tightening to a lower torque will reduce the response time of the sway bar (allowing more body roll), while higher torque values will stiffen the chassis and make the sway bar more responsive.
6. Check for any contact with the steering linkage, brake line or frame braces. Turn the wheel from full-lock left to full-lock right to verify sufficient clearance. Adjust the sway bar as needed.
7. Use caution on the first test drive until you are accustomed to the vehicles new response to steering inputs.

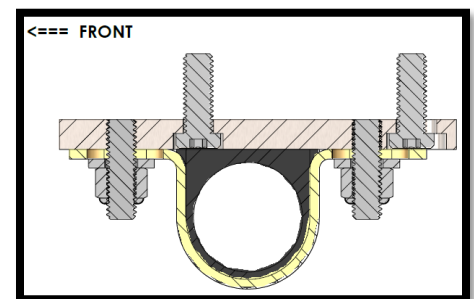
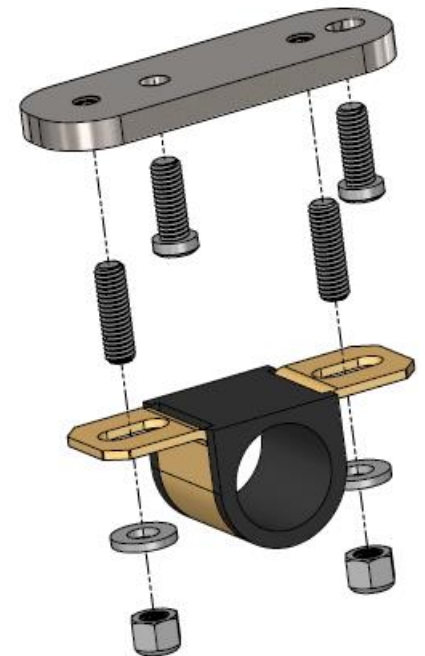

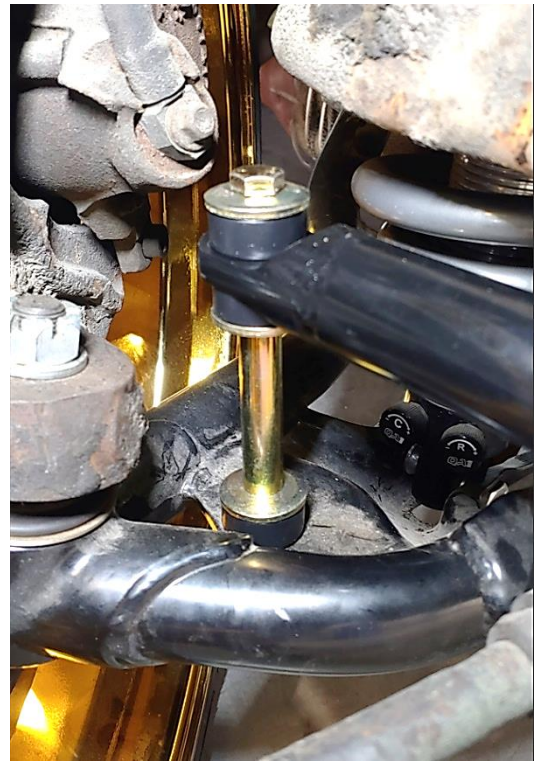
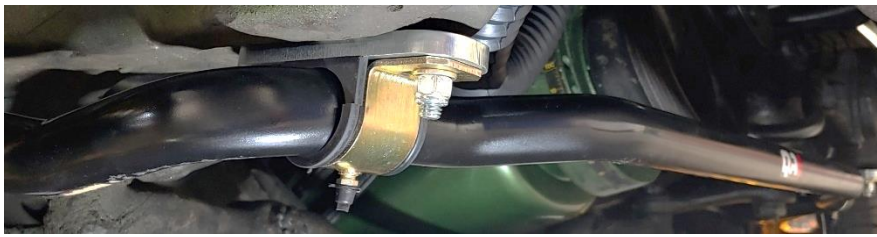

# QA1

Technical Support Line: (952) 985-5675 Email: [sales@QA1.net](mailto:sales@QA1.net)



READ ALL INSTRUCTIONS CAREFULLY AND THOROUGHLY PRIOR TO STARTING INSTALLATION. PRODUCTS THAT HAVE BEEN INSTALLED ARE NOT ELIGIBLE FOR RETURN. USE THE PROPER JACKING LOCATIONS. DEATH OR SERIOUS INJURY CAN RESULT IF INSTRUCTIONS ARE NOT CORRECTLY FOLLOWED. A GOOD CHASSIS MANUAL, AVAILABLE AT YOUR LOCAL PARTS STORE, MAY ALSO AID IN YOUR INSTALLATION.

• **DISCLAIMER / WARRANTY** •

QA1 WARRANTS THAT THE PRODUCTS WILL BE FREE FROM DEFECTS IN MATERIAL AND WORKMANSHIP FOR ONE YEAR FROM DATE OF SALE TO THE ORIGINAL PURCHASER. QA1 MAKES NO OTHER WARRANTY OF ANY KIND, EXPRESS OR IMPLIED. QA1 SHALL HAVE NO OBLIGATION UNDER THE FOREGOING WARRANTY WHERE THE DEFECT IS THE RESULT OF IMPROPER OR ABNORMAL USE, YOUR NEGLIGENCE, VEHICLE ACCIDENT, IMPROPER OR INCORRECT INSTALLATION OR MAINTENANCE, NOR WHEN THE PRODUCT HAS BEEN REPAIRED OR ALTERED IN ANY WAY. QA1'S LIABILITY IN THE CASE OF DEFECTIVE PRODUCTS SUBJECT TO THE FOREGOING WARRANTY SHALL BE LIMITED TO THE REPAIR OR REPLACEMENT, AT QA1'S OPTION, OF THE DEFECTIVE PRODUCTS.

THE USER UNDERSTANDS AND RECOGNIZES THAT RACING PARTS, SPECIALIZED STREET ROD EQUIPMENT, AND ALL PARTS AND SERVICES SOLD BY QA1 ARE EXPOSED TO MANY AND VARIED CONDITIONS DUE TO THE MANNER IN WHICH THEY ARE INSTALLED AND USED. QA1 SHALL BEAR NO LIABILITY FOR ANY LOSS, DAMAGE OR INJURY, EITHER TO A PERSON OR TO PROPERTY, RESULTING FROM THE INSTALLATION, DIRECT OR INDIRECT USE OF ANY QA1 PRODUCTS OR INABILITY BY THE BUYER TO DETERMINE PROPER USE OR APPLICATION OF QA1 PRODUCTS. WITH THE EXCEPTION OF THE LIMITED LIABILITY WARRANTY SET FORTH ABOVE, QA1 SHALL NOT BE LIABLE FOR ANY CLAIMS, DEMANDS, INJURIES, DAMAGES, ACTIONS, OR CAUSES OF ACTION WHATSOEVER TO BUYER ARISING OUT OF OR CONNECTED WITH THE USE OF ANY QA1 PRODUCTS. MOTORSPORTS ARE DANGEROUS; AS SUCH, NO WARRANTY OR REPRESENTATION IS MADE AS TO THE PRODUCT'S ABILITY TO PROTECT THE USER FROM INJURY OR DEATH. THE USER ASSUMES THAT RISK!