

Technical Support Line: (952) 985-5675 Email: sales@QA1.net

INSTALLATION INSTRUCTIONS

QA1 P/N

Rxxx-175- Rear Suspension, MOPAR A, B & E BODY

52830- Rear Sway Bar

TOOLS AND SUPPLIES REQUIRED

- Floor Jack
- Two (2) Jack Stands
- Mig Welder
- SAE Wrench Set
- Angle Finder
- Anti-seize
- Angle Grinder
- Ratchet & SAE Socket Set
- Torque Wrench
- Mig welder capable of ¼" penetration

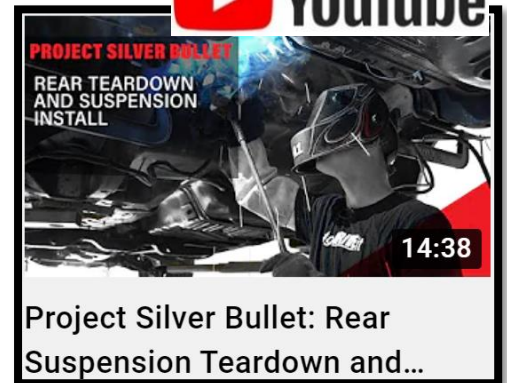
PRE INSTALLATION NOTES:

Removal of the gas tank is recommended for this installation. Ensure the tank is less than 1/4 full before starting this project to aid in the removal.

DISASSEMBLY-

1. Disconnect the vehicle battery.
2. Raise the rear of the car and support it with jack stands on a stable surface.
3. Remove the rear shocks and driveshaft from the car.
4. Remove the rear section of the exhaust. If the exhaust is one continuous section it can be removed after the axle is out of the car.
5. Disconnect the brake line junction on the axle.
6. Loosen (but do not remove yet) the rear leaf spring shackles and the front leaf spring brackets.
7. Lower the rear of the car so that the tires just make contact with the ground without putting a load on the leaf springs.
8. Remove the leaf spring hardware that was loosened in step 5 to free the axle and leaf springs from the car.
9. Raise and secure the rear of the car to a workable height.
10. Roll the axle and leaf springs out of the way in preparation for the installation. **(Figure 1)**
11. Disconnect the fuel lines/filler tube from the gas tank and remove the tank from the car. Be cautious of any remaining fuel in the tank.
12. Cap and tuck the remaining fuel line away from the frame rails where welding will be needed.

WATCH THIS INSTALLATION ON:



INSTALLATION-

1. Test fit the new cross member between the frame rails. The two "V" grooves will line up with the bolts of the factory bump stop. The larger trailing arm mounting tabs of the cross-member will point towards the front of the car. **(Figure 2)** Depending on the condition of the chassis, some massaging may be needed to ensure a snug fit. If more than 1/8" gap is present between the cross-member and the frame rails a similar thickness plate will need to be welded to the frame before installing the cross-member.



• **Figure 2**

2. Mark the area of the frame where the new cross-member will make contact.
3. Remove the cross-member from the car.
4. Clean the area where the new cross-member will be welded to bare metal. Weld-through primer can be used for corrosion resistance before the cross-member is reinstalled. **(Figure 3)**
5. Clamp the cross-member onto the frame rails lining up the small "V" grooves with the mounting bolts of the factory bump stop. **(Figure 4)**



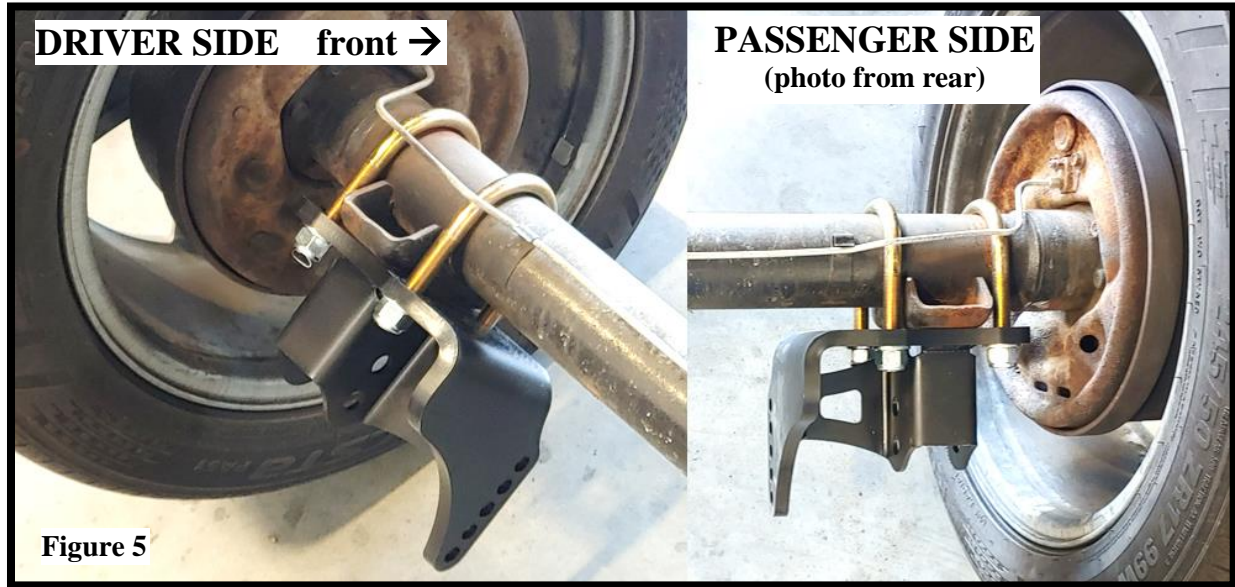
Figure 3

6. Using an angle finder, ensure the shock mounting tabs are vertical or slightly angled towards the rear of the car. Set the crossmember as low as possible without any portion of the side plates hanging lower than the frame rail.
7. Plug weld all holes in the side plates of the cross-member to the frame rails. It is recommended to do one hole per side at a time as to not introduce too much heat into the frame rail.
8. Prime and paint all bare metal to prevent corrosion.



Figure 4

9. Identify the right and left axle brackets and install them onto the axle using the included u-bolts, washers, and nylock nuts. The locating dowel on the bracket will locate the bracket on the factory leaf spring perches. **(Figure 5)** Torque to 79 lb. ft.



10. Mount the trailing arm brackets to the factory front leaf spring mount using 3/8" x 1.25" hardware with two nuts and nylock nut. These brackets are not right/left specific and will be mounted with the 90-degree edge mounted up. Torque to 31 lb. ft.

(Figure 6)



11. Mount the red anodized shock mounts to the inboard side of the axle brackets. These shock mounts will use a longer 1/2" x 2.75" through bolt, washer, and nylock nut in the top connection. Install the shorter 1/2" x 1.25" bolt with washer into the lower threaded hole of the shock mount. **(Figure 7)**

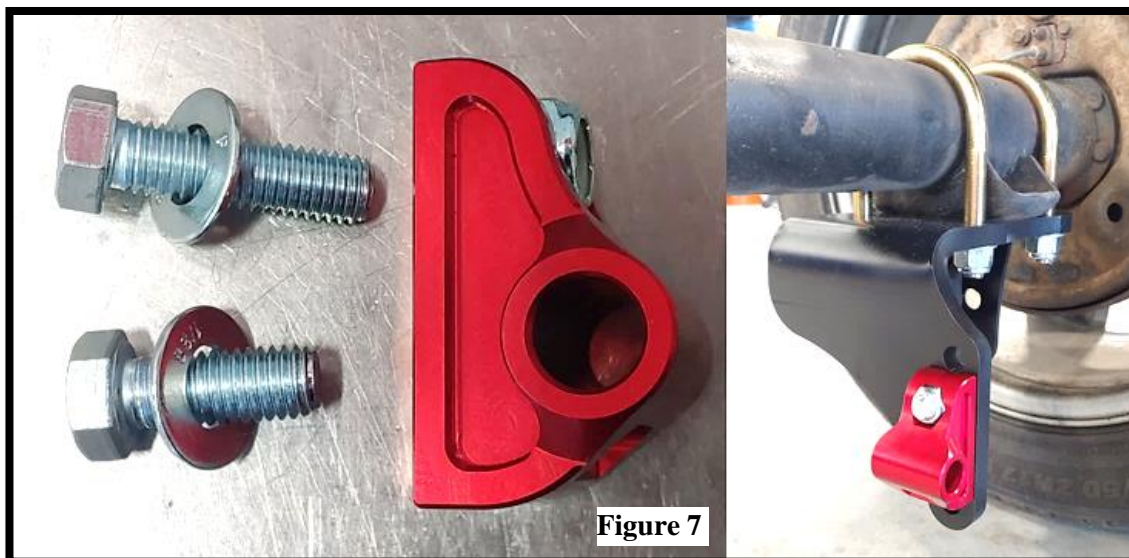




Figure 8

12. To assemble the lower trailing arms, thread one right-hand jam nut onto the XMR10-12 rod end. **(Figure 8)**
13. With anti-seize on the threads, thread the rod end into the lower trailing arm.
14. Adjust the lower trailing arms by turning the rod end in or out to the correct center to center length on the bolt holes. Ensure that both arms are exactly the same length.

All A-Body: 20-5/16"
'66 - '72 B-Body: 22-5/16"
'70 - '74 E-Body: 22-5/16"



15. Install the bushing end of the lower trailing arm into the middle front hole of the QA1 front mount with the grease fitting facing down. The front set of holes in the mounting bracket are the factory location. Further rear wheel placement can be adjusted using the rear row of holes. **(Figure 9)** Attach using 5/8" x 4" bolts, with two washers and nylock nut. The rear axle will need to be mocked up with these lower control arms, the shocks, and the upper trailing arms so attaching these lower control arms to the axle is not needed at this time.

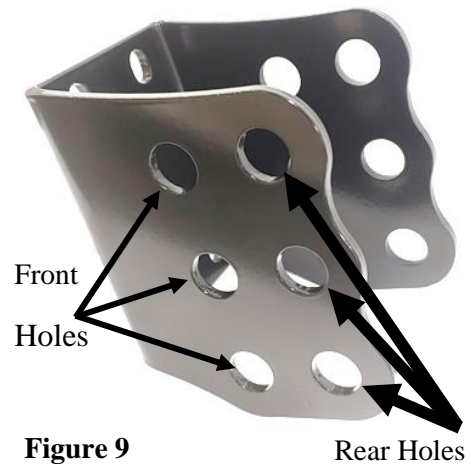


Figure 9

Rear Holes

16. Hang the shocks onto the cross-member using 1/2" x 2.75" hardware with two washers and nylock nut. Torque to 50 lb. ft. At this time it isn't necessary to install the coil springs onto the shocks for axle mock up.
17. Thread the right-hand jam nuts onto the remaining four rod ends and the left-hand jam nuts onto the left-hand rod ends. These will be used to assemble the upper trailing arms. **(Figure 10)**
18. Using anti-seize on the threads, thread the right-hand rod ends into the right-hand threaded end of the red anodized upper trailing arm. Thread the left-hand rod ends into the left-hand threaded end of the trailing arm. **(Figure 10)**

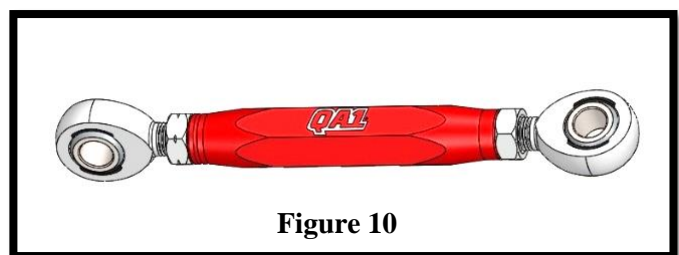
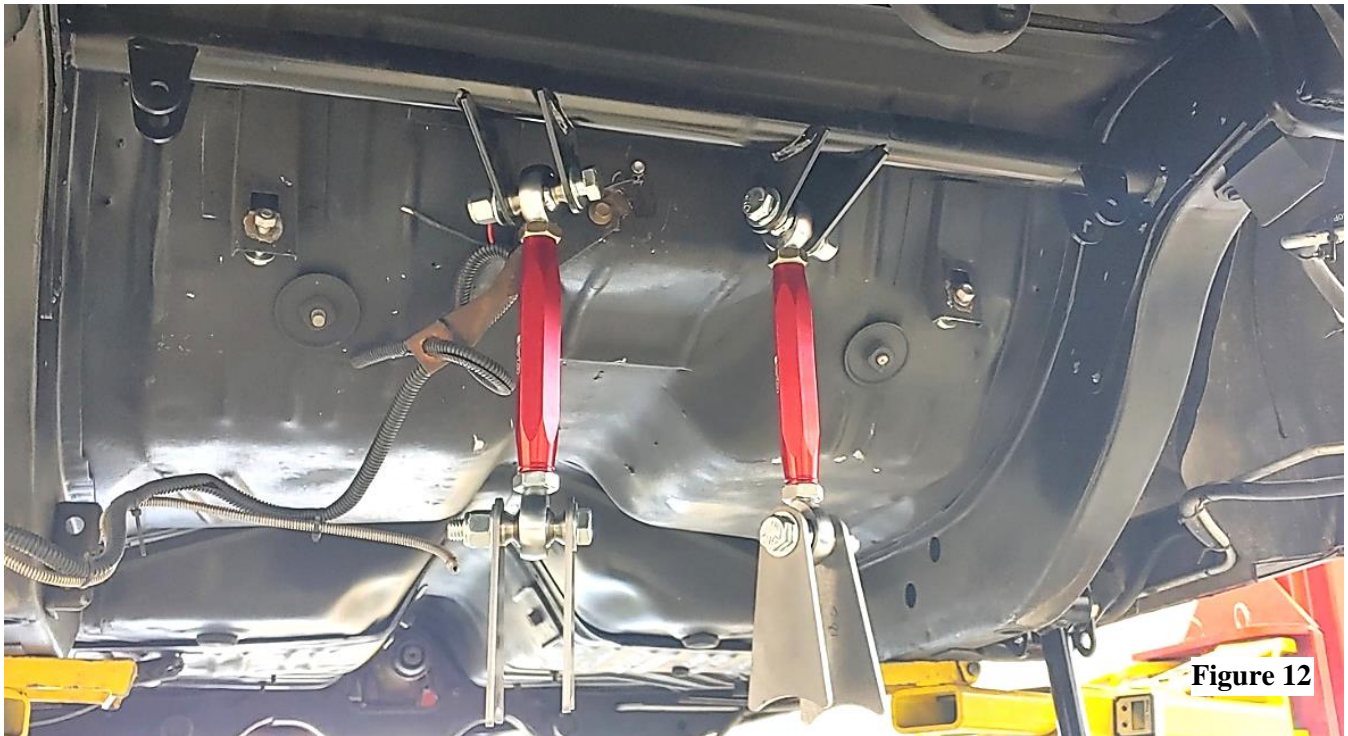
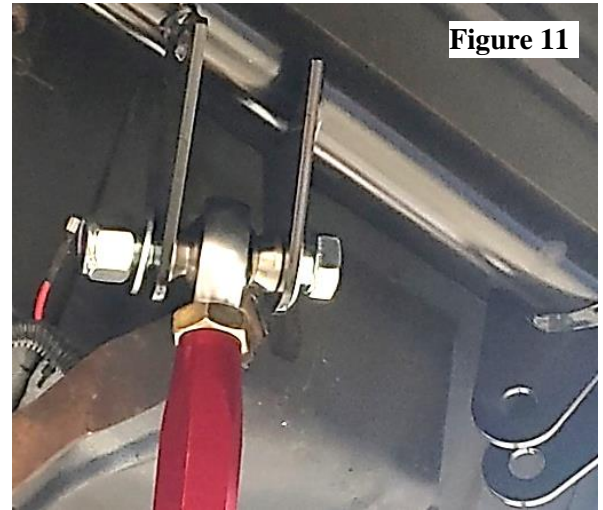


Figure 10

19. Adjust the upper trailing arm to a center/center length of 10.75" with equal thread engagement of the rod ends.

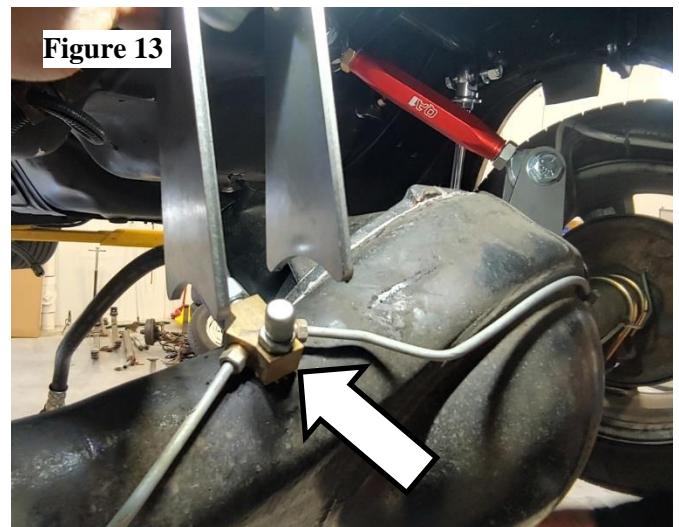
20. Install one SG108 spacer into both sides of the rod end bore and hang the arm from the cross-member using 5/8" x 3.5" hardware with two washers and nylock nut. **(Figure 11)** Torque to 72 lb. ft.

21. Assemble the axle side of the upper trailing arm using the included axle mounting tabs. There are two different lengths of axle tab. The shorter tabs will be installed on the inboard side of the rod end and the longer tabs on the outboard side of the rod ends. Install one SG108 spacer on each side of the rod end bore with the axle tabs in the correct positions and secure using 5/8" x 3.5" hardware, two washers per connection with nylock nut. **(Figure 12)**



22. Remove the bolt holding the brake line junction to the axle and move the junction away from the axle. **(Figure 13)**

23. Remove all dirt and paint from the axle in the area where the upper trailing arm mounts will be welded. Figure 12 shows the location where the mounts will need to be welded.



24. With the upper trailing arms, lower trailing arms and shocks attached to the chassis, roll the axle into place under the car with a jack supporting the pinion.



25. Lower the car down over the axle and attach the lower control arms to the middle hole of axle brackets using one SG108 spacer on each side of the rod end. Attach using 5/8" x 2.75" bolts with two washers and nylock nut.

26. Attach the shock to the axle bracket using 5/8" x 4.5" bolts with the included 3/4" stand-off spacer. **(Figure 14)** The final torque for this connection is 50 lb. ft., although the axle will need to be removed again before final installation.

NOTE: If the vehicle is equipped with a leaf spring relocation kit the shock can be mounted on the outboard side of the axle bracket to keep the shock vertical.

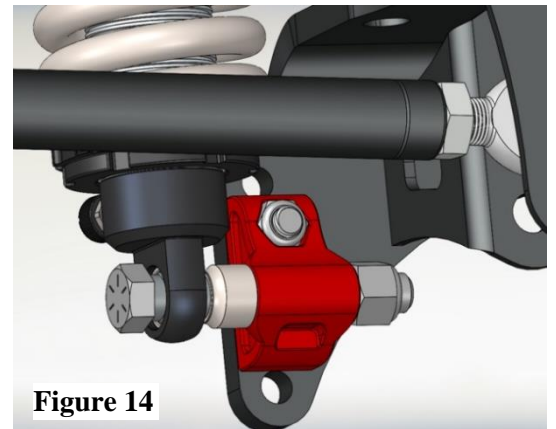


Figure 14

27. Raise the axle to your desired ride height ensuring that the axle is centered between the frame rails. **(Figure 15)** Measure the wheel base from the front wheels to ensure the axle is true.

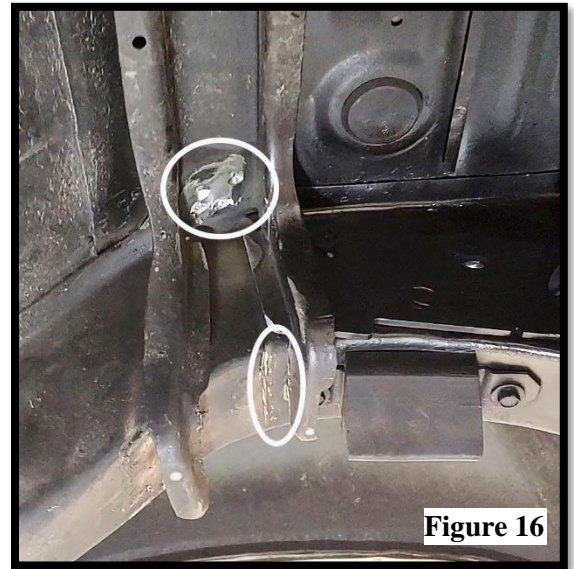
28. Support the pinion and adjust the pinion angle to 1 degree down with an angle finder. **(Figure 15)** The pinion angle is in relation to the angle of the transmission output and not from earth level.

29. At the desired ride height, the lower trailing arms should be parallel to the ground. Adjust the arms on the front or rear mounting holes until the arms are parallel.

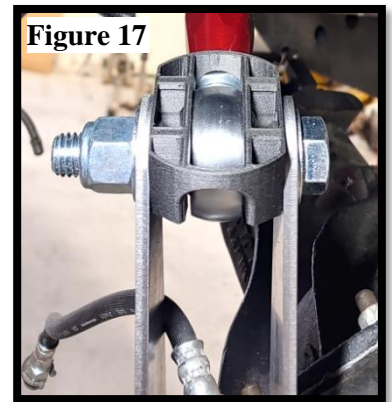


Figure 15

30. Measure the ground to fender height through the center of the wheel so that this ride height can be duplicated after final assembly. Measuring the axle to lower frame rail can serve as a secondary measurement.
31. Check the clearance of the upper trailing arms to the cross-member where the factory shocks were mounted. In some vehicles at lowered ride heights the upper control arms will not have enough clearance with this cross-member. If the cross-member needs to be removed it can be removed during step 37. The spot welds are located near both frame rails. **(Figure 16)**



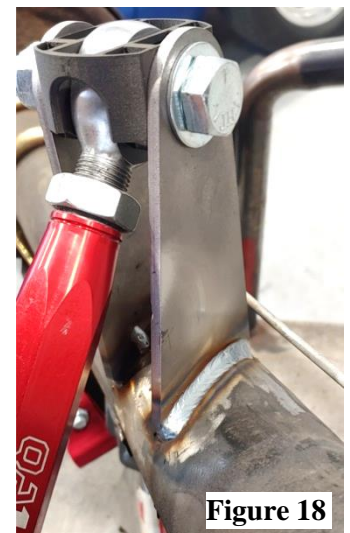
32. With the axle exactly where it will be during operation, make sure your upper trailing arms are set to a center to center starting length of 10.75".
33. Install the 3D printed rod end braces onto the front and rear rod ends of the upper trailing arms with the axle mounts resting on the axle. **(Figure 17)**
34. Tack-weld the outside face of the upper control arm mounts to the axle. Ensure you have enough weld penetration so the mounts will not move from their intended location.
35. Double check that your axle is at ride height, centered within the frame rails, and your pinion angle is still set to 1 degree negative (down).



NOTE:

The trailing arm mounts will need to be welded to the axle with sufficient penetration. The welder used for finish welding should have the ability to penetrate 1/4" steel.

36. Remove the axle from the car and finish weld the upper trailing arm mounts. **(Figure 18)** Do not finish weld the axle mounts with the rod ends connected to the mounts as it may melt the PTFE liner inside of the rod end.
37. If during step 31 it was determined that the original cross-member for the factory shock mount was too close to your upper control arms, remove it by grinding the spot welds as shown in Figure 15.
38. Prime and paint the axle to prevent corrosion.
39. Re-install the gas tank into the car before final axle installation. The tank can be installed after the axle but will be much easier if you install it before the axle.

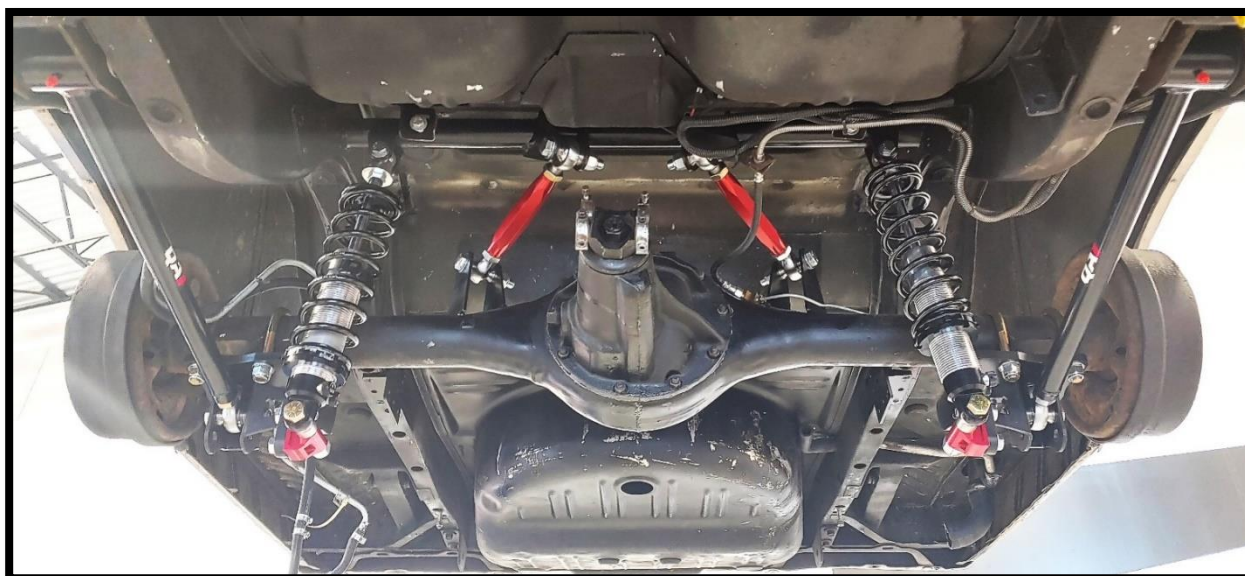


40. Refer to the coil-over installation instructions included with the shocks and install the coil-over hardware and springs onto the shocks.
41. Re-install the axle into the vehicle.
42. Adjust the coil-overs to your desired ride height figured during the mock-up.
43. Torque the lower shock mounting bolts to 50 lb. ft. Do not over-tighten as this may damage the spherical bearing.
44. With the vehicle at ride height, torque all upper and lower trailing arm hardware to 90 lb. ft. and tighten all jam nuts.
45. Re-install the fuel tank, exhaust, driveshaft, and all other components removed during disassembly to complete the installation.

NOTE:

If installing the QA1 rear sway bar, refer to the sway bar installation (on the next page) before re-installing the fuel tank as it will need to be removed again while welding the sway bar brackets to the frame.

A professional four-wheel alignment is required before driving the vehicle.



SWAY BAR INSTALLATION-

NOTE:

To ensure optimum clearances for the sway bar it will be necessary to install the fuel tank. The fuel tank will need to be removed to weld the end link brackets to the frame. Never weld next to a fuel source. Alternatively, the brackets can be mounted to the frame using 3/8" thread cutting screws, Fastenal p/n 31161507. (Figure 19)



Figure 19

1. Thread one 1/2" jam nut onto each 1/2" male rod end.
2. Thread the studded male rod end into the female rod end until the center-to-center length is 3.5", then tighten the jam nut against the female rod end. (Figure 20)
3. With the center of the sway bar facing downward and the legs of the bar towards the rear of the car, loosely install the axle u-bolts around the axle through the axle brackets and sway bar using one 7/16" washer and nylock nut per connection. The axle brackets will need to be mounted to the axle at an angle. (Figure 21)



Figure 20

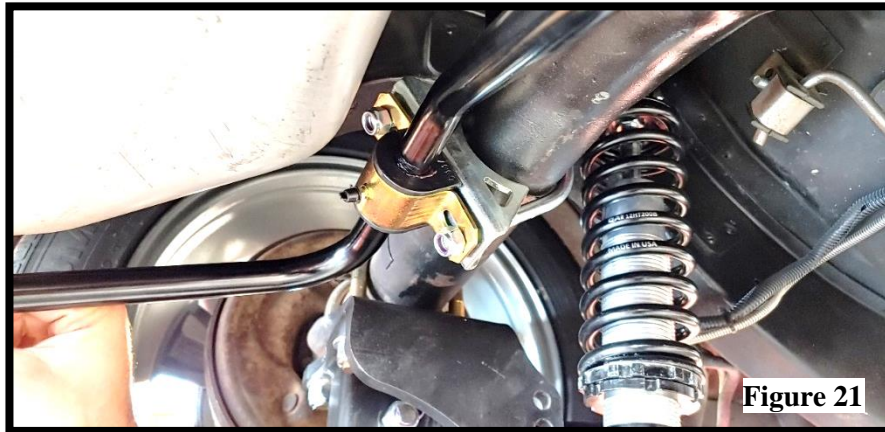


Figure 21

NOTE:

The configuration and mounting of the end links and end link brackets will vary as this sway bar fits the A, B and E body platforms. It will be necessary to mock the sway bar up at your desired ride height to ensure clearance and ideal frame bracket location.

4. Swing the legs of the sway bar up to the frame rail to check the clearance of the bar around the axle and fuel tank. This should be done at ride height. Rotate the axle brackets as needed to achieve the best fit.
5. With the legs of the bar held up to the frame rail, determine the best location for the mounting bracket (inside or outside of the frame rails) for the end link to be installed. The bar clamp will be installed on the bar with the end link mounting hole outboard of the bar, with the end link hole either above or below the bar. (Figure 22) The length of the sway bar going through the bar clamp is only dependent on the best fitment around the fuel tank and axle.
6. With the sway bar, end link and end link bracket mocked up at ride height mark the frame rail for the bracket mounting.
7. Mount the bracket to the frame rail by welding or by using 3/8" thread cutting screws mentioned above. Do not weld the brackets to the frame with the fuel tank installed as this could cause a fire.
8. Double check all work and hardware before driving the vehicle.

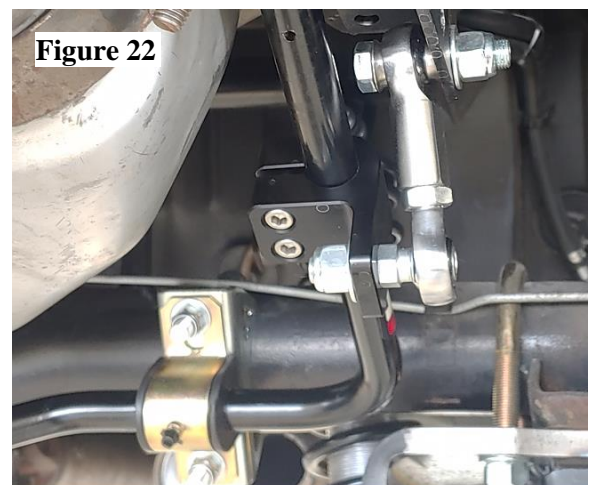
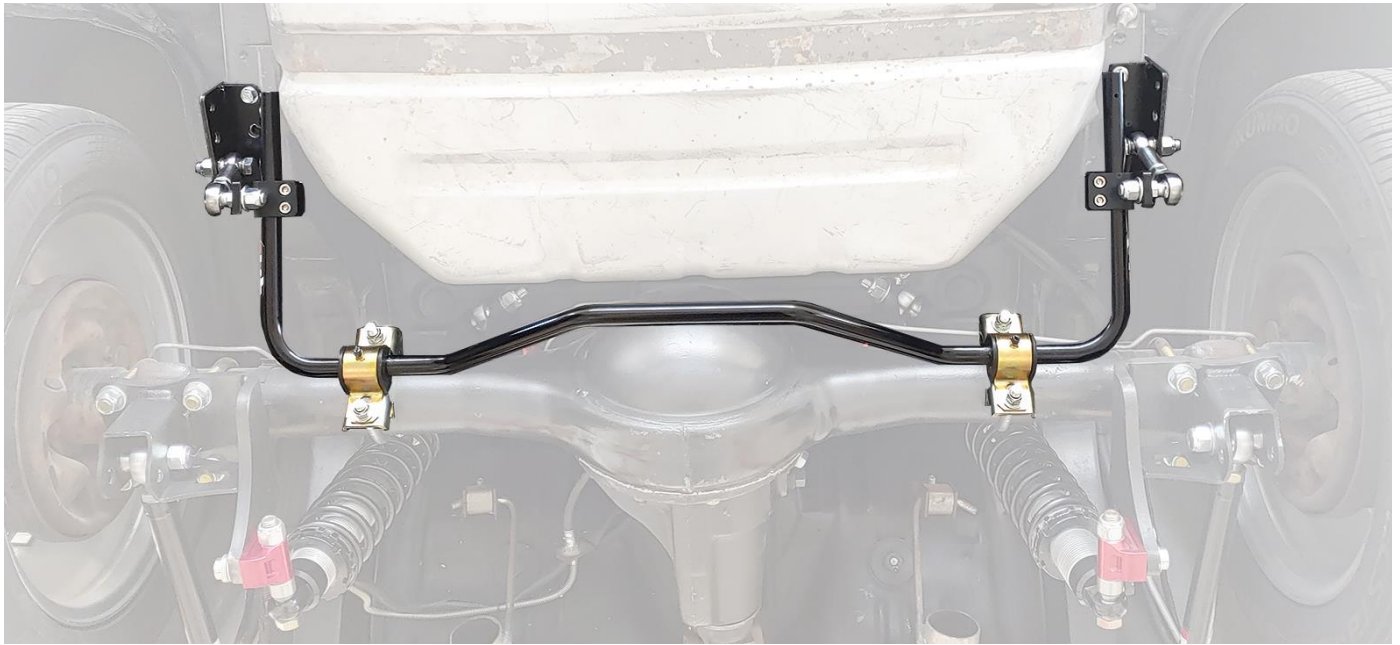


Figure 22



Technical Support Line: (952) 985-5675 Email: sales@QA1.net

READ ALL INSTRUCTIONS CAREFULLY AND THOROUGHLY PRIOR TO STARTING INSTALLATION. PRODUCTS THAT HAVE BEEN INSTALLED ARE NOT ELIGIBLE FOR RETURN. USE THE PROPER JACKING LOCATIONS. DEATH OR SERIOUS INJURY CAN RESULT IF INSTRUCTIONS ARE NOT CORRECTLY FOLLOWED. A GOOD CHASSIS MANUAL, AVAILABLE AT YOUR LOCAL PARTS STORE, MAY ALSO AID IN YOUR INSTALLATION.

• DISCLAIMER / WARRANTY •

QA1 WARRANTS THAT THE PRODUCTS WILL BE FREE FROM DEFECTS IN MATERIAL AND WORKMANSHIP FOR ONE YEAR FROM DATE OF SALE TO THE ORIGINAL PURCHASER. QA1 MAKES NO OTHER WARRANTY OF ANY KIND, EXPRESS OR IMPLIED. QA1 SHALL HAVE NO OBLIGATION UNDER THE FOREGOING WARRANTY WHERE THE DEFECT IS THE RESULT OF IMPROPER OR ABNORMAL USE, YOUR NEGLIGENCE, VEHICLE ACCIDENT, IMPROPER OR INCORRECT INSTALLATION OR MAINTENANCE, NOR WHEN THE PRODUCT HAS BEEN REPAIRED OR ALTERED IN ANY WAY. QA1'S LIABILITY IN THE CASE OF DEFECTIVE PRODUCTS SUBJECT TO THE FOREGOING WARRANTY SHALL BE LIMITED TO THE REPAIR OR REPLACEMENT, AT QA1'S OPTION, OF THE DEFECTIVE PRODUCTS.

THE USER UNDERSTANDS AND RECOGNIZES THAT RACING PARTS, SPECIALIZED STREET ROD EQUIPMENT, AND ALL PARTS AND SERVICES SOLD BY QA1 ARE EXPOSED TO MANY AND VARIED CONDITIONS DUE TO THE MANNER IN WHICH THEY ARE INSTALLED AND USED. QA1 SHALL BEAR NO LIABILITY FOR ANY LOSS, DAMAGE OR INJURY, EITHER TO A PERSON OR TO PROPERTY, RESULTING FROM THE INSTALLATION, DIRECT OR INDIRECT USE OF ANY QA1 PRODUCTS OR INABILITY BY THE BUYER TO DETERMINE PROPER USE OR APPLICATION OF QA1 PRODUCTS. WITH THE EXCEPTION OF THE LIMITED LIABILITY WARRANTY SET FORTH ABOVE, QA1 SHALL NOT BE LIABLE FOR ANY CLAIMS, DEMANDS, INJURIES, DAMAGES, ACTIONS, OR CAUSES OF ACTION WHATSOEVER TO BUYER ARISING OUT OF OR CONNECTED WITH THE USE OF ANY QA1 PRODUCTS. MOTORSPORTS ARE DANGEROUS; AS SUCH, NO WARRANTY OR REPRESENTATION IS MADE AS TO THE PRODUCT'S ABILITY TO PROTECT THE USER FROM INJURY OR DEATH. THE USER ASSUMES THAT RISK!