



**DON'T FORGET**

These instructions can be found in color and expandable at QA1.net

### INSTALLATION INSTRUCTIONS

QA1 P/N 52866 Rear Sway bar for QA1 Suspension System  
'65-'72 Ford F100

### TOOLS AND SUPPLIES REQUIRED

- Floor Jack
- Jack Stands
- SAE Wrench Set
- SAE Ratchet & Socket Set

**NOTE: The Shock mounts on the factory axle will need to be removed to install this sway bar.**

1. Jack the rear of the truck up and securely place on jack stands.
2. Mount one Inner Frame Bracket on driver and passenger side with the shared mounting holes of the frame notch bracket using 7/16" bolts, washers, and nylock nuts. Mount bracket forward and mounting bolts towards rear for both driver and passenger side. Torque to 49 lb. ft.

**(Figure 1 & 2)**

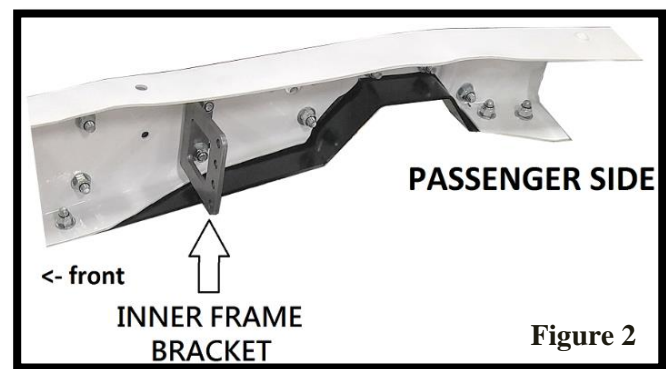
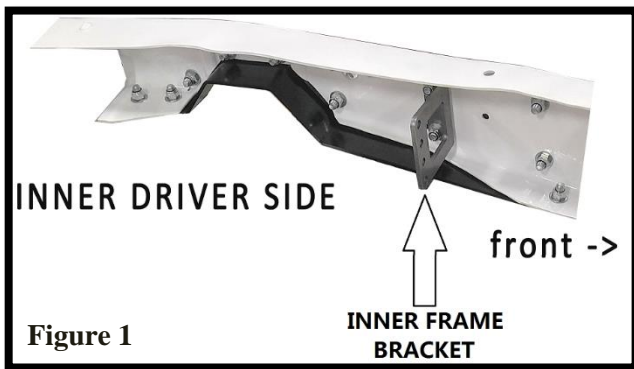

3. Install bushings and chassis mounts onto sway bar. **(Figure 3)**
4. Mount the sway bar chassis mounts to the axle using the included axle u-bolts, 1/2" washers, and 1/2" nuts. Evenly space sway bar to frame mounts. Torque to 70 ft. lb. **(Figure 4 & 5)**



**INSTALL NOTE:**

Brake line junction on the axle may need to be spaced off the axle as to not interfere with driver side axle u-bolt. **(Figure 6)**

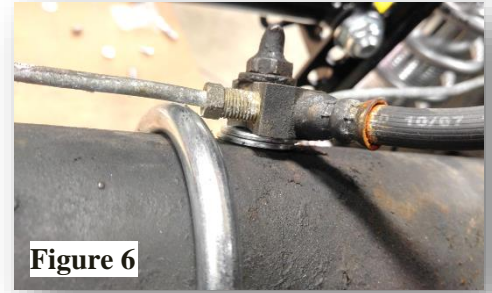

5. Install 1/2" right hand thread jam nuts onto right hand thread rod ends and thread into anodized red adjustment sleeve. Do the same on the left hand thread side of the adjuster sleeve with left hand thread jam nut on left hand thread rod end. Thread rod ends all the way into the adjustment sleeve. **(Figure 7)**



6. Attach one end of the assembled sleeve to the frame mount using two high misalignment spacers installed into the rod end. Fasten to frame mount using 3/8" x 2.5" bolts, with washer on the nylock nut side of the mount. The sway bar link will mount to the rear of the mount in the third hole from the top as a starting point. Torque to 31 lb. ft. **(Figure 8)**



7. Attach sway bar to adjuster link using specialty high misalignment stud with 1/2" washer and nylock nut on the sway bar side. Attach link side using high misalignment spacer and a 3/8" nylock nut. Torque connection to 31 lb. ft. **(Figure 9)**

8. At ride height, adjust end links so that the sway bar is parallel with the ground. Tighten jam nuts to complete the install.
9. Grease zerk fittings with 2-3 pumps of marine grease for bushing connections.

BALLOON #	ITEM #	DESCRIPTION	QTY.
1	9033-459	SLEEVE, .875"HEX ALUMINUM ANODIZED	2
2	9037-628	BRACKET, AXLE SADDLE MOUNT, 3 INCH	2
3	9037-677	SWAY BAR, REAR 1 1/4", BLACK	1
4	9037-701	PLATE, SWAY BAR MOUNT	2
5	7039-228	HARDWARE KIT, REAR SWAY BAR	1
6	XMR8	ROD END (X) ENDURA ALLOY HT	2
7	JNR8S	Jam Nut, Right Hand Thread	2
8	XML8	ROD END (X) ENDURA ALLOY HT	2
9	JNR8S	Jam Nut, Left Hand Thread	2
10	SG8-64	High Misalignment Spacer, SS	6
11	9029-309	HIGH MISALIGNMENT STUD	2
12	9012-204	U-BOLT, 7/16-20 X 3.125" X 4.5"	2
13	9032-171	BUSHING, SWAY BAR FRAME MOUNT 1-1/4"	2

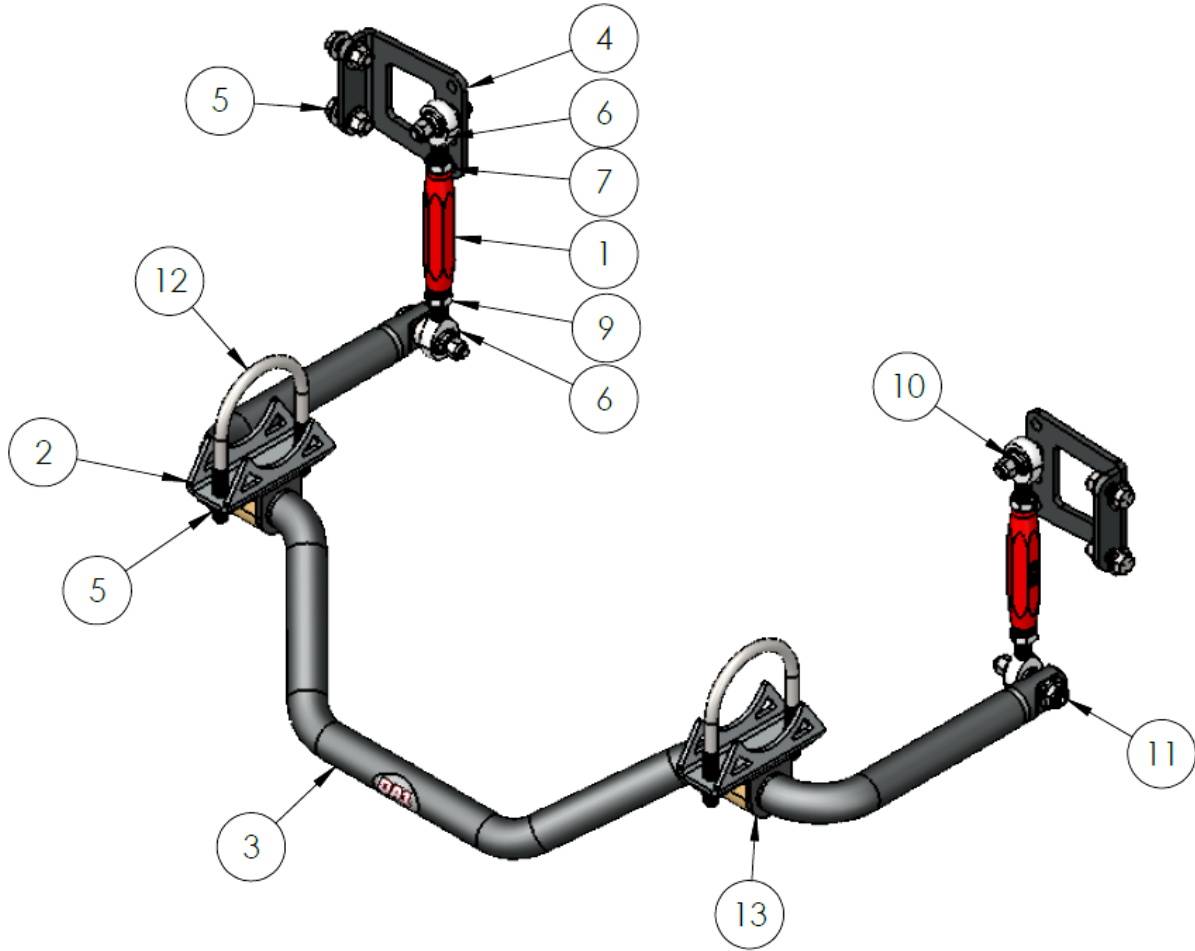

HARDWARE KIT, REAR SWAY BAR, 67-72 FORD F100	
1st Description	Qty.
BOLT, 3/8-16 X 2.5"	2
NUT, NYLOCK, 3/8-16	2
WASHER, SAE, 3/8	2
BOLT, 7/16-14 X 1.25"	4
NUT, NYLOCK, 7/16-14	4
WASHER, SAE, 7/16	12
WASHER, SAE, 1/2	2
NUT, NYLOCK, THIN JAM, 1/2-20	2

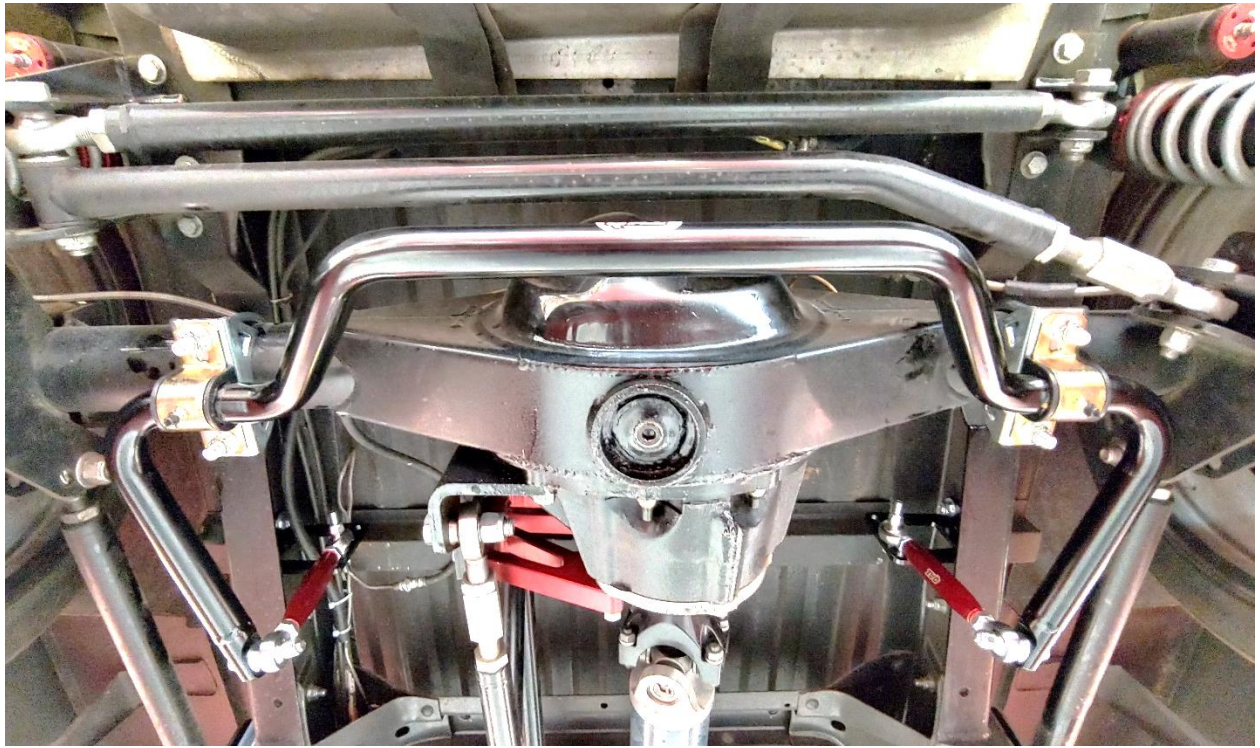

**Technical Support Line: (952) 985-5675 Email: [sales@QA1.net](mailto:sales@QA1.net)**

READ ALL INSTRUCTIONS CAREFULLY AND THOROUGHLY PRIOR TO STARTING INSTALLATION. PRODUCTS THAT HAVE BEEN INSTALLED ARE NOT ELIGIBLE FOR RETURN. USE THE PROPER JACKING LOCATIONS. DEATH OR SERIOUS INJURY CAN RESULT IF INSTRUCTIONS ARE NOT CORRECTLY FOLLOWED. A GOOD CHASSIS MANUAL, AVAILABLE AT YOUR LOCAL PARTS STORE, MAY ALSO AID IN YOUR INSTALLATION.

**• DISCLAIMER / WARRANTY •**

QA1 WARRANTS THAT THE PRODUCTS WILL BE FREE FROM DEFECTS IN MATERIAL AND WORKMANSHIP FOR ONE YEAR FROM DATE OF SALE TO THE ORIGINAL PURCHASER. QA1 MAKES NO OTHER WARRANTY OF ANY KIND, EXPRESS OR IMPLIED. QA1 SHALL HAVE NO OBLIGATION UNDER THE FOREGOING WARRANTY WHERE THE DEFECT IS THE RESULT OF IMPROPER OR ABNORMAL USE, YOUR NEGLIGENCE, VEHICLE ACCIDENT, IMPROPER OR INCORRECT INSTALLATION OR MAINTENANCE, NOR WHEN THE PRODUCT HAS BEEN REPAIRED OR ALTERED IN ANY WAY. QA1'S LIABILITY IN THE CASE OF DEFECTIVE PRODUCTS SUBJECT TO THE FOREGOING WARRANTY SHALL BE LIMITED TO THE REPAIR OR REPLACEMENT, AT QA1'S OPTION, OF THE DEFECTIVE PRODUCTS.

THE USER UNDERSTANDS AND RECOGNIZES THAT RACING PARTS, SPECIALIZED STREET ROD EQUIPMENT, AND ALL PARTS AND SERVICES SOLD BY QA1 ARE EXPOSED TO MANY AND VARIED CONDITIONS DUE TO THE MANNER IN WHICH THEY ARE INSTALLED AND USED. QA1 SHALL BEAR NO LIABILITY FOR ANY LOSS, DAMAGE OR INJURY, EITHER TO A PERSON OR TO PROPERTY, RESULTING FROM THE INSTALLATION, DIRECT OR INDIRECT USE OF ANY QA1 PRODUCTS OR INABILITY BY THE BUYER TO DETERMINE PROPER USE OR APPLICATION OF QA1 PRODUCTS. WITH THE EXCEPTION OF THE LIMITED LIABILITY WARRANTY SET FORTH ABOVE, QA1 SHALL NOT BE LIABLE FOR ANY CLAIMS, DEMANDS, INJURIES, DAMAGES, ACTIONS, OR CAUSES OF ACTION WHATSOEVER TO BUYER ARISING OUT OF OR CONNECTED WITH THE USE OF ANY QA1 PRODUCTS. MOTORSPORTS ARE DANGEROUS; AS SUCH, NO WARRANTY OR REPRESENTATION IS MADE AS TO THE PRODUCT'S ABILITY TO PROTECT THE USER FROM INJURY OR DEATH. THE USER ASSUMES THAT RISK!

# Dedicated Technical Support Team

QA1 is dedicated to providing quality support and instructions. We employ passionate racers and car enthusiasts that know our products and the industry to better serve you.

Check out our tech videos at [www.YouTube.com/QA1Tech](http://www.YouTube.com/QA1Tech) for:

- Frequently Asked Questions
- Quick Tips
- Install Information
- Tuning and Repair Guides
- Other technical information

Or call to speak with one of our experts: 1.800.721.7761

\*Our technical support and order lines are open Monday - Friday, 8 am to 5 pm CST.

 [Facebook.com/QA1Motorsports](https://www.facebook.com/QA1Motorsports)

 [Twitter.com/QA1Motorsports](https://twitter.com/QA1Motorsports)

 [Instagram.com/QA1Motorsports](https://www.instagram.com/QA1Motorsports)

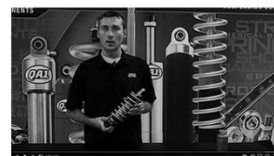

[www.QA1.net/Tech](http://www.QA1.net/Tech)