



Detroit Speed
LS Engine Mount Kit
 P/N: 060401DS

The Detroit Speed LS Engine Mount Kit enables easy, no hassle installation of any LS engine into a 1967-69 Camaro/Firebird or 1968-74 Nova stock front subframe. The kit comes with all hardware, engine mount stands, aluminum adapter plates and polyurethane mounts. We recommend using the GM 1998-2002 Camaro/Firebird F-Car oil pan, GM part number 12628771.



Item #	Description	Quantity
1	Engine Mount Adapter Plate, LH & RH	2
2	Frame Stand, LH & RH	2
3	Polyurethane Engine Mounts	2
4	M10-1.5 x 30 Countersunk Bolt	2
5	M10-1.5 x 30 Flange Head Bolt	4
6	M10-1.5 x 20 Flange Head Bolt	4
7	M10-1.5 x 40 Flange Head Bolt	2
8	M10 Flat Washer	10
9	7/16"-14 x 3-3/4"L Hex Head Bolt	2
10	7/16"-14 Hex Nut	2
11	7/16" Flat Washer	4
12	7/16" Lock Washer	2
13	3/8"-16 x 1.0"L Hex Head Bolt	6
14	3/8" Flat Washer	6

Fastener Torque Specifications	
Application	Torque (ft. /lbs.)
Adapter Plate to Engine Block (Aluminum Block)	25
Adapter Plate to Engine Block (Cast Iron Block)	35
Engine Mount to Adapter Plate (Upper Bolts)	25
Engine Mount to Adapter Plate (Lower Bolt - Aluminum Block)	25
Engine Mount to Adapter Plate (Lower Bolt - Cast Iron Block)	35
Frame Stand to Subframe	35
Frame Stand to Engine Mount	30

1. To begin installation, locate the engine mount adapter plates in the kit. The milled side of the mount will face away from the engine with the smooth side going to the block. The end of the adapter plate with the angle cut will go to the front of the vehicle.
2. To mount the engine mount adapter plate to the engine, use two M10-1.5 x 30 flange head bolts (#5), two M10 washers (#8) and one M10-1.5 x 30 countersunk bolt (#4) per side. Use anti-seize on these bolts. On aluminum engine blocks, torque the bolts to 25 ft. /lbs. and on cast iron blocks, torque to 35 ft. /lbs.
3. The engine mount will install next. Use two M10-1.5 x 20 flange head (#6) bolts and two M10 washers (#8) in the top of the mount. Install one M10-1.5 x 40 flange head bolt (#7) and one M10 washer (#8) in the bottom of the mount. Torque the upper bolts into the adapter plate to 25 ft. /lbs. For the lower bolt, torque to 25 ft. /lbs. on an aluminum block and 35 ft. /lbs. on a cast iron block. Again, use anti-seize on these bolts.
4. Attach the frame stands to the subframe using three 3/8"-16 x 1.0" L hex head bolts (#13) and three 3/8" flat washers (#14) per side. There is a LH and RH stand. Follow the pictures in Figures 1 & 2 for proper orientation. Use High Strength Loctite (p/n: 262) on these bolts when installing and torque the bolts to 35 ft. /lbs.

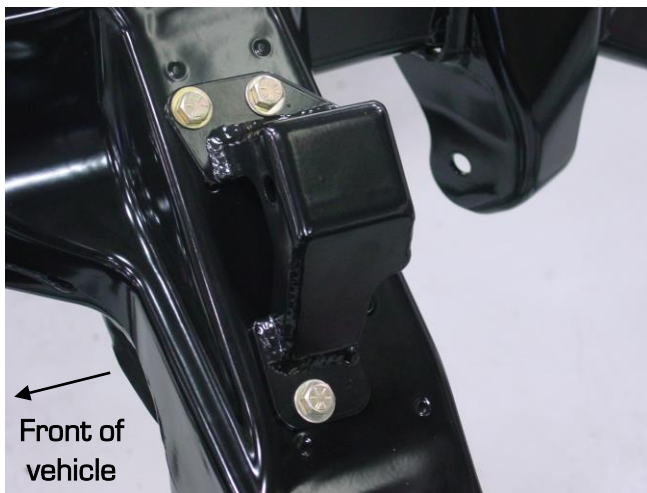

Figure 1 - RH engine stand



Figure 2 - LH engine stand

5. Once everything is positioned correctly on the frame and engine. Attach the engine to the frame using two 7/16"-14 x 3-3/4" L hex head bolts (#9). Use the provided 7/16" flat washers (#11), 7/16" lock washers (#12) and the 7/16"-14 hex nuts (#10) to tighten everything in place. Torque these bolts to 30 ft. /lbs. Figure 3 on the next page shows an assembled view.

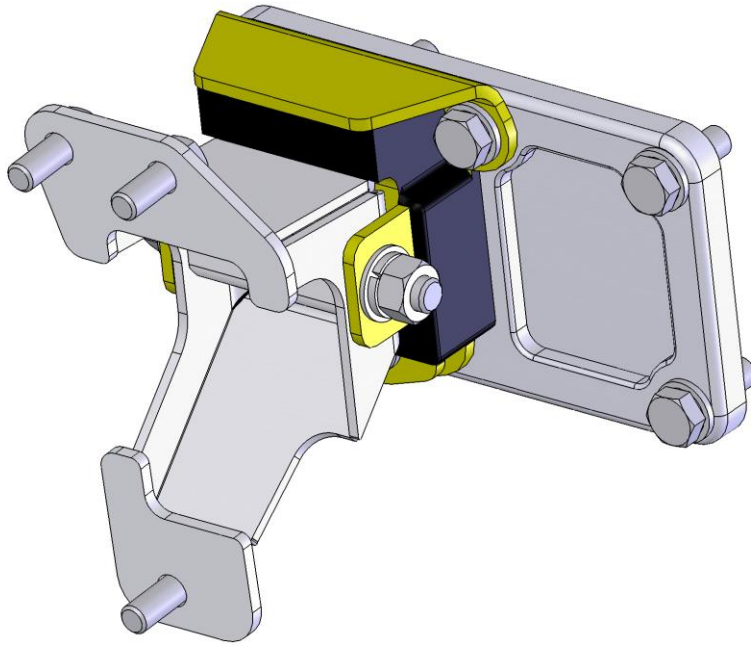

Figure 3 – Assembled View

If you have any questions before or during the installation of this product, please contact Detroit Speed at tech@detroitsspeed.com or 704.662.3272

Legal Disclaimer: *Detroit Speed is not liable for personal, property, legal, or financial damages from the use or misuse of any product we sell. The purchaser is solely responsible for the safety and performance of these products. No warranty is expressed or implied.*