

Detroit Speed  
X-Gen Universal QUADRALink Rear Suspension Kit  
Staggered  
P/N: 041725DS

Detroit Speed's universal staggered rear suspension system allows you to integrate Detroit Speed suspension technology into any vehicle and makes a great compliment to DSE's X-Gen series of front suspension systems. DSE's exclusive 4-link geometry design is uncompromised and designed to achieve the best possible handling during all conditions. The patented "Swivel-Link" technology in combination with tuned high-durometer rubber bushings allow the suspension to fully articulate with smooth silent motion. This system utilizes a horizontal track bar that provides precise and effective rear axle lateral location during hard cornering.

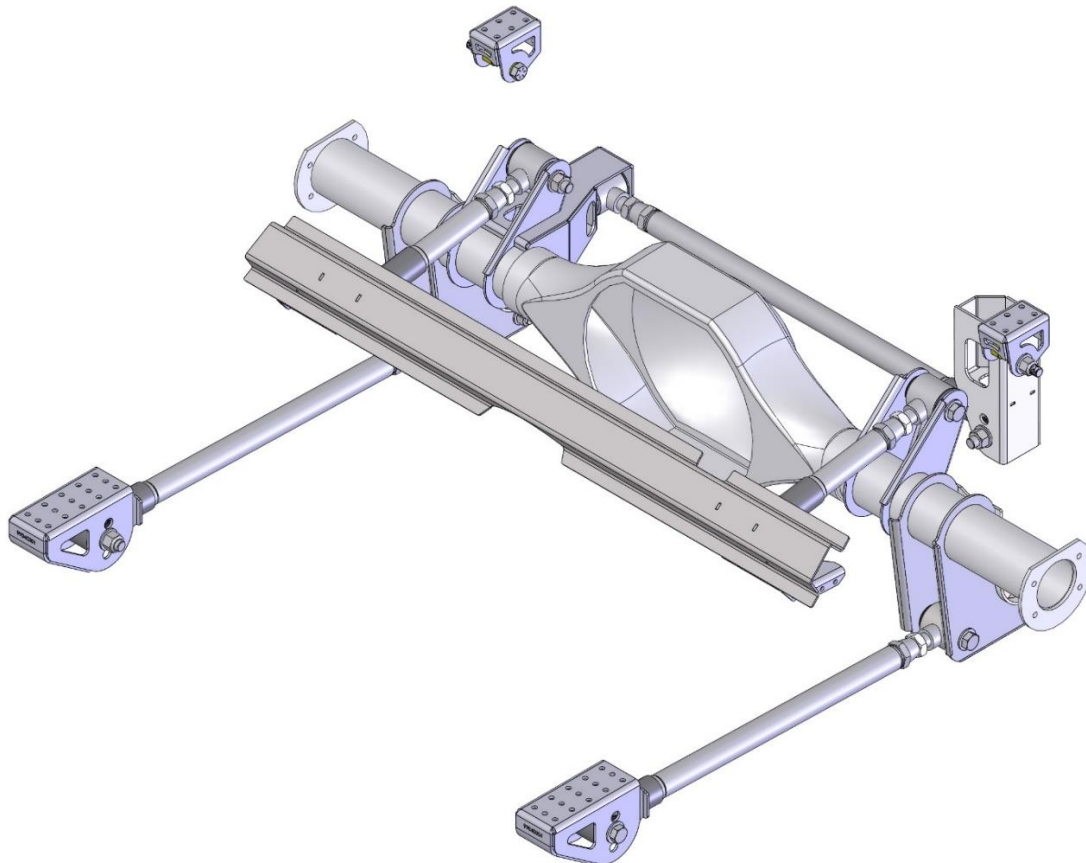

NOTE: Ford 9" housing is not provided

**IMPORTANT**

All work should be performed by a qualified welder and technician. Please read the entire set of instructions and fully understand all of the steps involved before beginning the project. Always make sure to wear the appropriate safety equipment for the job and properly support the vehicle. If you have any questions before, during, or after the installation, feel free to contact Detroit Speed by phone at (704) 662-3272 or by email at [tech@detroitsspeed.com](mailto:tech@detroitsspeed.com).

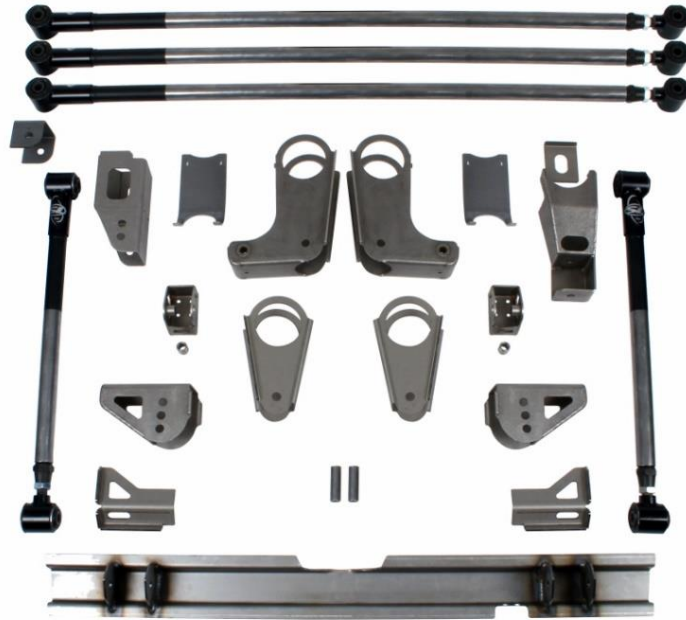

Item	Part Description	Quantity
1	Lower Link Chassis Mount	2
2	Upper Link Crossmember Assembly	1
3	Upper Link Closeout Bracket, LH and RH	2
4	Track Bar Chassis Mount	1
5	Upper Shock Mount Pocket, LH and RH	2
6	Lower Link/Coilover Axle Mount Bracket	2
7	Lower Link/Coilover Bracket Reinforcement	2
8	Upper Link Axle Mount Bracket	2
9	Track Bar Axle Mount Bracket	1
10	Track Bar Axle Bracket Reinforcement	1
11	2' Swivel-Link	2
12	4' Swivel-Link	3
13	Link/Shock Hardware Kit	1
14	Installation Kit	1
15	Instructions	1

Hardware Checklist - Universal Rear Suspension Kit			
Part Number	Description	Quantity	Check
<b>9304066</b>	<b>Link/Shock Hardware Bag</b>	<b>1</b>	
980034FS	9/16"-18 x 3-3/4" L Hex Head Bolt	10	
960022FS	9/16"-18 Nylock Nut	10	
970020FS	9/16" SAE Washer	20	
980021FS	1/2"-20 x 3-1/2" L Hex Head Lower Shock	2	
980000FS	1/2"-20 x 3-1/4" L Hex Head Upper Shock	2	
960004FS	1/2"-20 Nylock Nut	4	
970037FS	1/2" SAE Washer	6	
<b>9304067</b>	<b>Installation Bag</b>	<b>1</b>	
9304019	Axle Bracket Weld Spacers	2	
99030028	Upper Shock Mount Steel Bushing	2	

Fastener Torque Specifications		
Application	Torque (lbf-ft)	Threads
Swivel-Link and Track Bar Bolts	100	
Swivel-Link and Track Bar Jam Nuts	55	
Coilover Shock Mounting Bolts	60	Anti-Seize

**NOTE:** Due to the universal nature of this rear suspension kit, Detroit Speed does not include shocks or springs in this kit. Use the following chart as a guide for determining the correct shocks and spring rate for your application. Custom shocks and springs are available. Detroit Speed can help you with your shock and spring selection or any other questions you may have.

JRi/Detroit Speed Coilover Shocks					
Part Number	Adjustable	Jounce Bumper	Stroke	Overall Length	Ride Height*
041307DS	Non-Adjustable	3/4"	5"	17"	14" to 15"
041317DS	Single Adjustable	3/4"	5"	17"	14" to 15"
041308DS	Double Adjustable	3/4"	5"	17"	14" to 15"
041309DS	Double Adj. w/Canisters	3/4"	5"	17"	14" to 15"
041310DS	Non-Adjustable	3/4"	4-3/4"	16"	13" to 13-3/4"
041318DS	Single Adjustable	3/4"	4-3/4"	16"	13" to 13-3/4"
041311DS	Double Adjustable	3/4"	4-3/4"	16"	13" to 13-3/4"
041315DS	Double Adj. w/Canisters	3/4"	4-3/4"	16"	13" to 13-3/4"
041313DS	Non-Adjustable	3/4"	3-3/4"	14"	12" to 12-1/4"
041322DS	Single Adjustable	3/4"	3-1/2"	14"	12" to 12-1/4"
041314DS	Double Adjustable	3/4"	3-3/4"	14"	12" to 12-1/4"
041323DS	Double Adj. w/Canisters	3/4"	3-3/4"	14"	12" to 12-1/4"

\*Measured Center to Center between the upper and lower shock bolts.

Detroit Speed Coilover Springs			
Part Number	Free Length	Spring Rate (lbs./in)	Shock Stroke
041801DS	8"	250	3-1/2" to 4-3/4"
99030113	8"	450	3-1/2" to 4-3/4"
041816DS	10"	175	5"
041815DS	10"	275	5"
99030289	10"	400	5"
041808DS	11"	175	5"

#### Axle Bracket Installation:

1. If you are using a stock rear axle and will be replacing the housing ends, remove them from the axle tubes. Remove the factory leaf spring or coil spring brackets from the axle tubes (Figure 1). Grind the factory welds on the axle tubes for a clean finish.

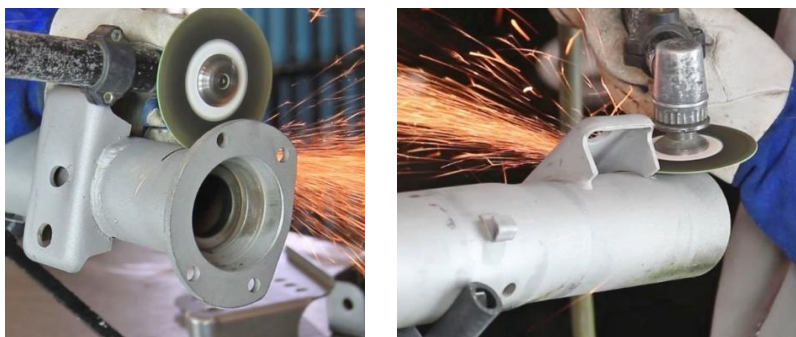

Figure 1 - Remove Housing Ends & Leaf/Coil Spring Brackets

2. Install the provided 2.42" L weld spacers into the axle bracket upper and lower link holes along with the provided 9/16"-18 bolts. Place the lower link/coilover axle bracket reinforcement onto the back of the axle bracket and weld in place. Grind the axle bracket smooth for a clean finish.
3. Prepare the axle tubes to weld the axle bracket to the axle. **NOTE:** The Detroit Speed axle brackets are designed for a 3" axle tube, so if you have smaller axle tubes, you will need to make an adapter ring.
4. Using a pinion centering tool, measure from the centerline of the rear axle outward in both directions to mark your axle bracket location. This will be the location where the inside edge of the axle brackets will be positioned. Use the diagram in these instructions to locate the axle brackets on the axle housing (Figure 7 on page 9). **NOTE:** Detroit Speed offers a pinion centering tool (P/N: 070202DS) that will be helpful in placing your axle brackets in the correct location on your axle tube. Draw a scribe line around the axle tube at the marked locations (Figure 2).

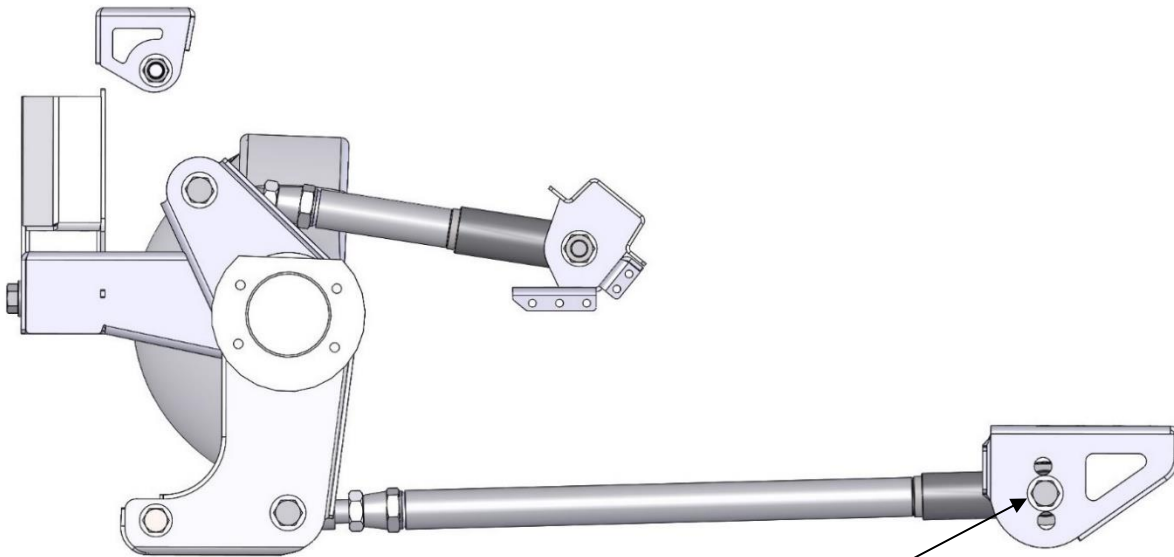

Figure 2 - Locate Axle Brackets on Axle Tubes

5. Install the axle brackets over the axle tubes and position the inside flange of the brackets at the scribed circle on the axle tubes. Clamp the rear axle in place on a bench. Rotate the housing forward so that the center section mounting flange is 2° down from vertical (Figure 7 on page 9). Install the 2.42" L weld spacers into the upper link holes along with the 9/16"-18 bolts.
6. Once the axle brackets are in the correct location, tack weld them to the axle tubes. Verify the correct location and then finish weld all the way around the brackets to the axle tubes.
7. The track bar axle bracket mounts on the rear of the passenger side upper link axle bracket (Figure 7 on page 9). The right side of the bracket lines up with the right side of the link bracket and is square to the axle tube. Position the track bar axle bracket reinforcement inside the upper link bracket.
8. Tack weld the track bar axle bracket and reinforcement in place, verify its position, and then weld it to the other bracket. Once all of the axle brackets are fully welded in place, remove the spacers, and check the axle for straightness.
9. At this point the fabrication on the rear axle housing is complete. Send the axle to a qualified shop to have the housing ends welded (if necessary). Check the axle tubes and have them straightened (if necessary).

**Chassis Bracket Installation:**

1. Place the rear axle housing under the frame and determine the ride height and wheel base of your vehicle.
2. Detroit Speed recommends installing the upper link pointing down 8.75° and the lower link pointing up 1.5° at ride height (Figure 7 on page 9). The lower link chassis mount has three holes for instant center and height adjustments (Figure 3).



***Nominal Position Shown***

Instant Center: 55.4" Forward of Rear Axle Centerline  
7.7" Above Ground Level

\* \*See Chart Below for Adjustment Information\* \*

<b>Lower Link Adjustment Settings</b>		
<b>Body Bracket Position</b>	<b>Instant Center</b>	<b>Height</b>
Top Hole	46.1"	9.1"
Middle Hole	55.4"	7.7"
Bottom Hole	69.2"	5.5"
<i>Instant center numbers are expressed as distance forward of rear axle centerline, then height above ground level</i>		

**Figure 3 – Lower Link Adjustment Settings**

3. Locate the upper link crossmember assembly to the vehicle. It can be placed inside the vehicle behind the back seat or in between the frame rails underneath the body.
  - a. If you plan on installing it on the inside of the vehicle, mark two 3" x 3" square areas for the upper link mounting tabs to pass through the trunk pan. These squares will need to be centered in the vehicle and the inside edges of the two squares will be 24-1/2" apart. Cut out the two marked square sections. Slide the upper link crossmember into place and insert the mounting tabs through the floor. Trim as needed to fit. Center and square the crossmember and clamp in place.

- b. If you plan on placing it underneath the body, center the assembly between the two inner frame rails. Trim the crossmember as needed to fit. Center and square the crossmember and clamp in place.
4. Position the upper link closeout brackets to fit on both tabs and against the inboard side of the frame rail or reinforcement. Trim as needed to fit. Tack weld the upper link crossmember and closeout brackets in place and verify their position [Figure 4].



**Figure 4 - Reinforcement Brackets**

5. Weld the upper link crossmember assembly and closeout brackets in place.
6. Locate the lower link chassis brackets underneath the frame rail and/or torque box. Tack weld the brackets in place, verify their position, and then fully weld [Figure 5].



**Figure 5 - Lower Link Bracket**

7. Position the track bar chassis mount into place on the driver's side framerail. Trim the bracket as needed to fit. The track bar mount should be located on the framerail so that the track bar is level with the ground in the bottom hole of the mount at ride height. Square the bracket so it is perpendicular to the ground and tack weld in place. Verify that the track bar bracket is level and finish weld around the perimeter of the bracket.

### Upper Shock Mounts:

1. With the rear axle positioned under the frame, locate the left and right hand upper shock mount brackets. The welded crush tube in the shock mounts should be to the outside of the vehicle.
2. With your ride height and shock length determined, the upper shock mounts will need to be welded directly over the lower shock mounts so that the shocks will stand straight up and down.
3. The upper shock mounts will need to be welded to an upper shock crossmember. Position them square to the cross member and tack weld them in place. Finish welding around the perimeter of the shock mounts to the cross member. (Figure 6).



Figure 6 - Weld Upper Shock Mounts

4. Use the provided 1/2"-20 fasteners to install your shocks into the upper and lower shock mounts. Use anti-seize on the threads of the bolts and torque to 60 lbf-ft. **NOTE:** The upper shock mount steel bushing will go onto the upper shock bolt and then pass through the upper shock mount from the center of the vehicle outwards.

### Universal Swivel-Link Assembly:

1. Determine the length of your trailing arm for your application. Install the adjuster end assembly into the weld nut leaving exposed threads for adjustment. **NOTE: There can be no more than 2" of exposed threads on the end link (3/4" of thread engagement in the tube).** This measurement does include the jam nut (See Page 10).
2. Install the weld nut and adjuster end into the Swivel-Link sleeve assembly and hold in place with tape for mock up purpose. Measure the length of the Swivel-Link to determine how much you need to shorten the tube for your application.
3. Remove the weld nut and adjuster end and cut the Swivel-Link sleeve down to fit your application. Tack weld the weld nut to the tube and thread the adjuster end into the Swivel-Link assembly. Install into your vehicle and check the length.
4. Once you have the correct length finish weld the weld nut to the Swivel-Link sleeve.
5. Repeat steps 1 thru 4 for the remaining links on your application.

6. Protect and paint your Swivel-Link Tubes. Assemble and install the Swivel-Links in your vehicle. **CAUTION:** Do not powder coat these links as that process will permanently damage the Swivel-Link.

### Final Assembly

1. Once all of the links are installed with the provided 9/16"-18 fasteners, verify the rear axle is centered in the car and the wheelbase is correct. Also, make sure the pinion angle is set correctly by using the upper link adjustments. The pinion angle should be measured and adjusted to your preference. 2° down is recommended. Verify your wheel base by using the lower link adjustments. It may be necessary to adjust the links both top and bottom to obtain proper fitment. **NOTE: There can be no more than 2" of exposed threads on the end link (3/4" of thread engagement in the tube). This measurement does include the jam nut (See page 10).**
2. Once the rear axle is in the proper position, torque the end link jam nuts to 55 lbf-ft. Do not torque the Swivel-Link hardware at this time.
3. Once the rest of the rear suspension is installed and the vehicle is close to completion, install the wheels/tires and rest the vehicle on all four tires. Double check that the rear axle is positioned correctly in the vehicle. It should be centered from side to side, and the wheelbase should be correct on both sides of the vehicle. Raise and lower the vehicle to verify that there is no interference.
4. Settle the suspension by bouncing the vehicle several times. With the vehicle at ride height, torque the Swivel-Link and track bar bolts to 100 lbf-ft. Confirm the rear axle position again. Double check that all of the bolts and jam nuts are tightened to their respective torque specifications.

If you have any questions before or during the installation of this product please contact Detroit Speed at [tech@detroitsspeed.com](mailto:tech@detroitsspeed.com) or 704.662.3272

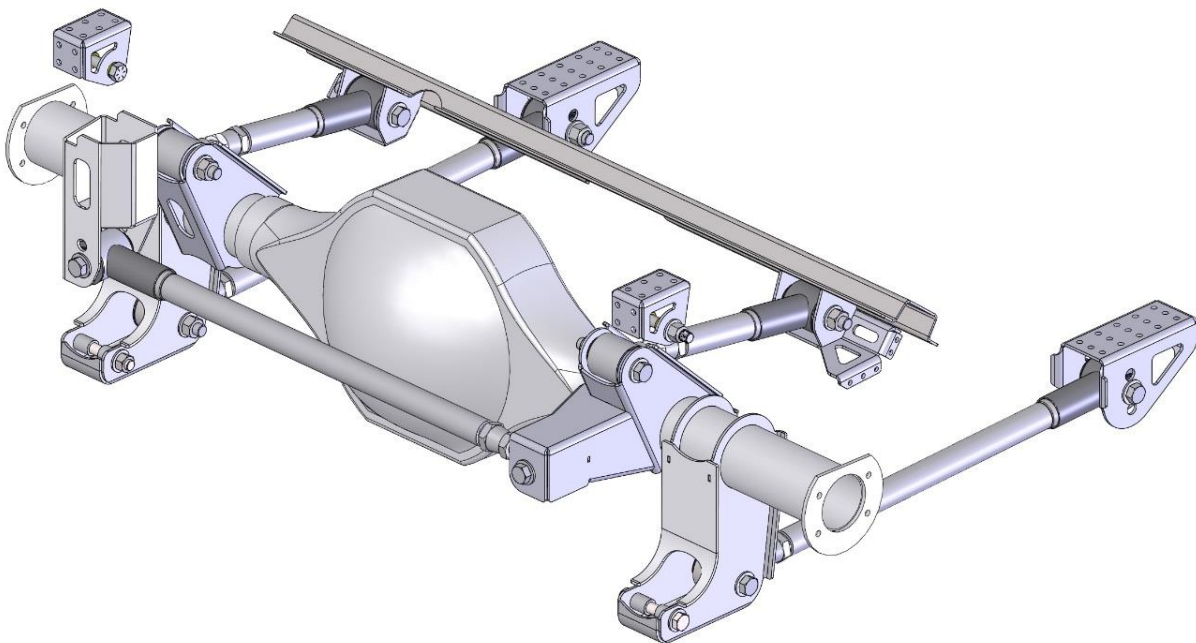

**Legal Disclaimer:** Detroit Speed is not liable for personal, property, legal, or financial damages from the use or misuse of any product we sell. The purchaser is solely responsible for the safety and performance of these products. No warranty is expressed or implied.



**UNIVERSAL STAGGERED REAR SUSPENSION  
AXLE BRACKET LOCATIONS**

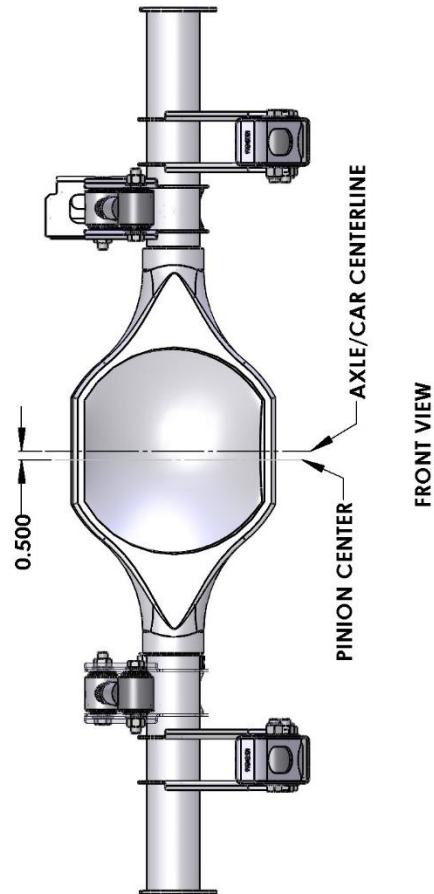
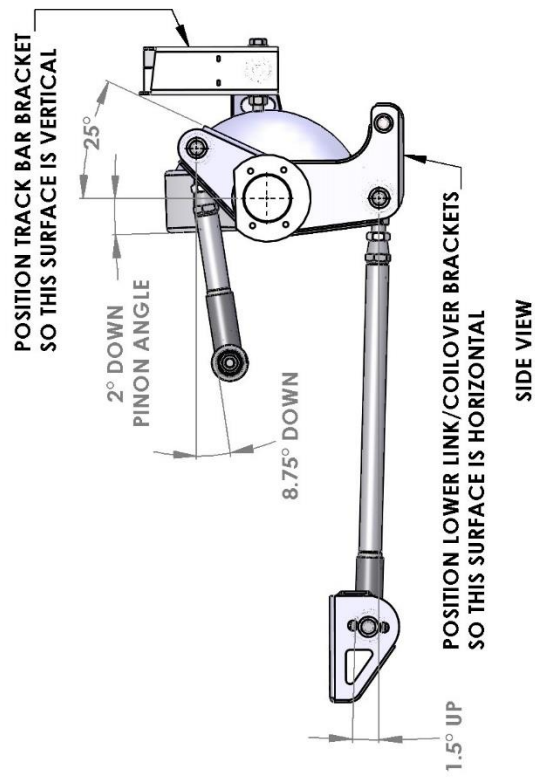
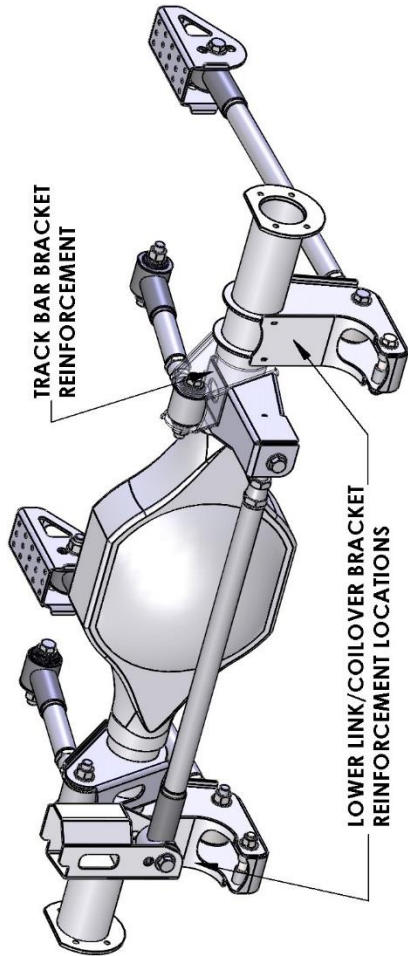

\*NOTE THAT THE CENTERLINE OF THE AXLE IS NOT LOCATED AT THE CENTER OF THE PINION, AND DEPENDING ON AXLE TYPE, MAY NOT BE LOCATED AT THE CENTER OF THE CARRIER HOUSING. THE PINION IS OFFSET TO THE PASSENGER SIDE OF THE VEHICLE. SE USES 1/2" OFFSET

**Figure 7 - Axle Bracket Location**

Once again, we appreciate your business.  
If you have any questions during the installation of this product, call (704) 662-3272.

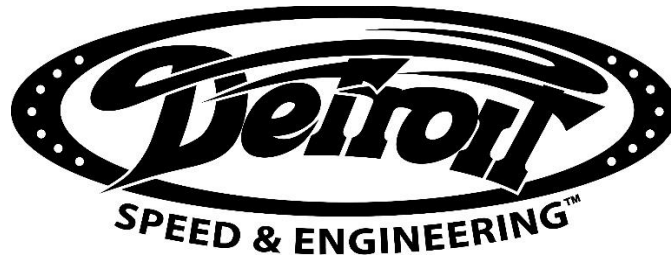

Detroit Speed  
Swivel-Links

**WARNING:**

There can be no more than 2" of exposed threads on the end link (3/4" of thread engagement in the tube). This measurement does include the jam nut (see below).

