



**Detroit Speed
QUADRALink Rear Suspension**

1964.5 - 1970 Mustang

P/N: 041731DS, 041731-SDS, 041731-DDS, 041731-RDS,
041733DS, 041733-SDS, 041733-DDS, & 041733-RDS

The Detroit Speed QUADRALink is a great way to upgrade from an original leaf spring rear suspension. Detroit Speed's exclusive 4-link geometry design is uncompromised and designed to achieve the best possible handling during all conditions. The patented Swivel-Link™ technology in combination with tuned high-durometer rubber bushings allow the suspension to fully articulate with smooth silent motion. This system utilizes a horizontal track bar that provides precise and effective rear axle lateral location during hard cornering. The track bar is adjustable for roll center control at various ride heights, and the rear crossmembers add strength and rigidity to the rear body and frame section.

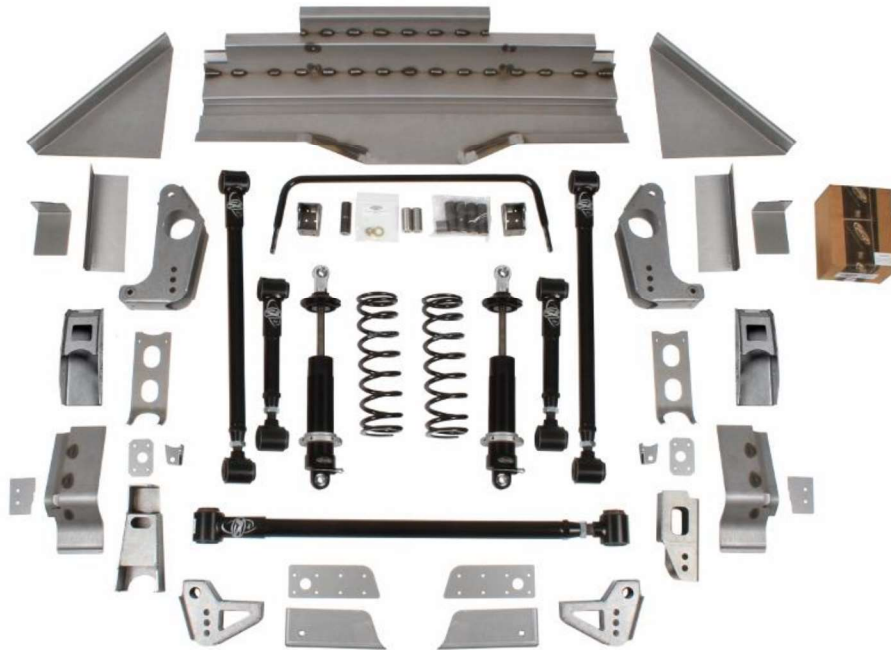

P/N: 041731DS Shown

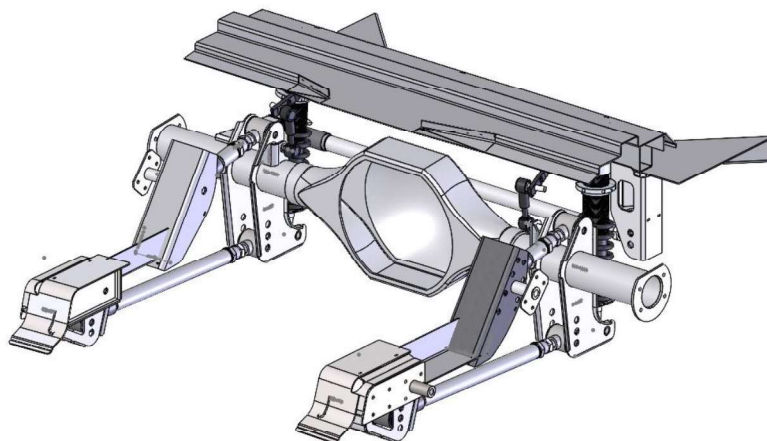

Introduction

Congratulations on your purchase of a QUADRALink rear suspension from Detroit Speed. This system is designed to be installed with or without Detroit Speed's Mini-Tubs. (If you don't install the Mini-Tub Kit in your car, you still need to install the Detroit Speed Frame Rail Kit). The binding, noise, and poor wear associated with Heim joints are no longer an issue. The jam nuts on a typical adjustable bushed link tend to loosen due to suspension bind when going over uneven surfaces (like pulling into a driveway). The Swivel-Links on the QUADRALink suspension permit the links to pivot, thus eliminating bind and unwanted torsional loading of the jam nuts. The long suspension links provide excellent pinion and u-joint angle control.

Please read the instructions carefully and completely before beginning the installation. Always make sure to wear the appropriate safety equipment for the job and properly support the vehicle. If you have any questions before, during, or after the installation, feel free to contact us by phone at (704) 662-3272 or by email at tech@detroitsspeed.com.

NOTE: All work should be performed by a qualified welder and technician.

Item	Component	Quantity
1	Upper Crossmember Assembly	1
2	Torque Box Kit	1
3	Lower Link/Coilover Axle Bracket	2
4	Lower Link/Coilover Axle Bracket Reinforcement	2
5	Front Lower Link Mounting Bracket	2
6	Front Upper Link Mounting Bracket - Left	1
7	Front Upper Link Mounting Bracket - Right	1
8	Front Upper Link Mount Frame Rail Doubler	2
9	Front Upper Link Mount Frame Rail Crush Tube	2
10	Frame Closeout	2
11	Track Bar Axle Bracket	1
12	Track Bar Body Bracket	1
13	Upper Shock Mount - Left	1
14	Upper Shock Mount - Right	1
15	Lower Link - Adjustable with Swivel-Link	2
16	Upper Link - Adjustable with Swivel-Link	2
17	Track Bar - Adjustable with Swivel-Link	1
18	Sway Bar	1
19	Sway Bar End-Link Axle Bracket - Left	1
20	Sway Bar End-Link Axle Bracket - Right	1
21	Sway Bar Polyurethane Bushing	2
22	Sway Bar Mounting Bracket	2
23	Sway Bar Male/Female End-Link Assembly with Jam Nut & Fasteners	2
24	Front Trunk Corner Closeouts	2
25	Detroit Speed Valved Coilover Shock	2
26	Coilover Spring	2
27	1" OD x 3.0" L Crush Tube	2
28	Mustang Torque Box Closeout	2
29	1-1/4" OD x 1" ID x 1" L Spacer	1
30	3/4" OD x 1/2" ID x 3/4"L Spacer	2
31	Spacer, 2.42" Long - For Fabrication Use Only	1
32	Super Grease Packet	2
33	Templates	2
34	Instructions	1

Hardware Checklist - DSE Mustang QUADRALink Kit			
Part Number	Description	Quantity	Check
9304362	Mustang Torque Box Hardware Kit	1	
960052FS	1/2"-20 Hex Nut	1	
970037FS	1/2" SAE Flat Washer	1	
9304407	Mustang QUADRALink Hardware Kit	1	
980140FS	9/16"-18 x 7" L Hex Head Bolt	2	
980034FS	9/16"-18 x 3-3/4" L Hex Head Bolt	8	
980077FS	1/2"-20 x 7" L Hex Head Bolt	2	
980021FS	1/2"-20 x 3-1/2" L Hex Head Bolt	2	
980058FS	1/2"-20 x 3" L Hex Head Bolt	2	
980027FS	3/8"-16 x 1" L Hex Head Bolt	4	
960022FS	9/16"-18 Nylock Nut	10	
960100FS	9/16"-18 Hex Nut	1	
960004FS	1/2"-20 Nylock Nut	6	
970020FS	9/16" SAE Flat Washer	20	
970037FS	1/2" SAE Flat Washer	10	
970023FS	3/8" SAE Flat Washer	4	

NOTE: There is an installation video available through the Detroit Speed website in the tech/install video shown here: detroitsspeed.com/blog/post/detroit_speed_1964_5-70_mustang_quadralink_rear_suspension_system_install.

NOTE: It is highly recommended to install the Detroit Speed Mustang Subframe Connector Kit in conjunction with this installation. It is also easier to install the subframe connector kit & torque boxes first before starting the QUADRALink installation.

NOTE: If you are not installing the Detroit Speed Mini-Tubs, you will need to close-out the area at both ends of the QUADRALink upper shock crossmember since it won't reach the stock inner tub.

Installation Instructions

Before beginning the installation, read and comprehend the entire set of instructions. These written instructions should be used as a supplement to the installation video on the Detroit Speed website. The installation video is a detailed step-by-step install video.

1. With the vehicle at ride height verify that the rear axle is in the correct position and mark the fore/aft location of the axle on the rear frame rails and trunk floor.
2. With the Raise the vehicle a few feet off the ground so the interior, trunk and underside may be accessed. Ensure that the vehicle is level and well supported.
3. Disconnect the negative battery cable.
4. Remove the rear suspension and axle. Remove the fuel tank and lines.
5. Remove the seats, carpet and padding, rear interior quarter trim panels, and package tray. Any other interior panels, headliner, door panels, etc., should be removed or masked well to protect them from grinding and welding sparks.

6. With the fuel tank removed, draw a cut line where the factory crossmember and trunk floor pan meet (Figure 1).



Figure 1 - Mark Floor Pan Cut Line (Underneath Vehicle)

7. Mark a horizontal line 1-1/4" from the fuel tank mounting flange between the framersails. Continue this line along the inside and top side of the frame rail on the driver's side. Continue the horizontal line up the inside and top side of the frame rail on the passenger side. Draw a diagonal cut line from the corner of the front fuel tank opening to the 1-1/4" horizontal line where it meets the framersail (Figure 2).



Figure 2 - Mark Floor Pan Cut Lines (Trunk)

8. Begin cutting along the top side of the passenger side frame rail, down the inside of the framersail and along the short diagonal cut line to the corner of the fuel tank opening (Figure 3). Be careful not to cut through the floor pan sheet metal through the Detroit Speed frame rail section installed during the Mini-Tub installation.



Figure 3 - Cut Floor Pan (Passenger Side)

9. Make a diagonal cut on the driver's side from the front corner of the fuel tank opening to the 1-1/4" line where it meets the inside frame rail (Figure 4). Make a straight cut from the fuel tank opening to the 1-1/4" line. Then cut over from the trunk pan to the inside frame rail. Cut up the inside frame rail and over the top of the frame rail, being careful not to cut through the Detroit Speed frame rail section.

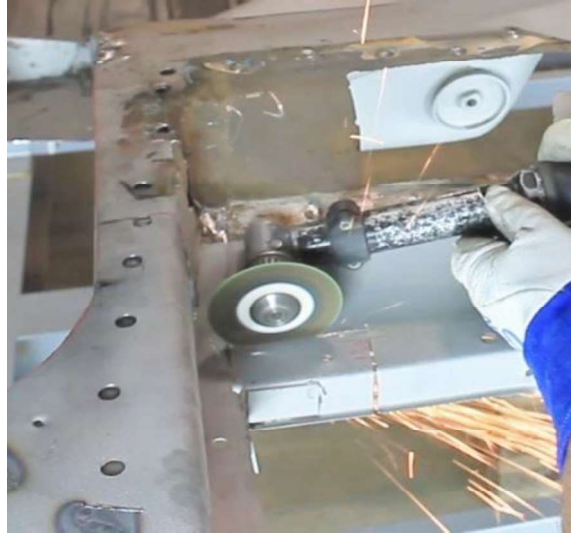

Figure 4 - Cut Floor Pan (Driver Side)

10. Cut the front of the trunk pan where you previously drew a line where the factory crossmember and the trunk floor meet. Remove this section of trunk floor from the vehicle (Figure 5). Grind the layers of sheet metal at the crossmember cut lines smooth.



Figure 5 - Remove Trunk Floor Section

11. Drill out the spot welds holding the brake line bracket to the floor pan on the driver's side and remove the bracket (Figure 6). Grind this area clean for a smooth finish.



Figure 6 - Remove Brake Line Bracket

12. Cut out the provided template for the upper link mount hole location and place it on the outside frame rail per the notes on the template. Make sure the bottom edge of the template is level with the frame rail. Center punch the upper link hole location on the template to the outside frame rail (Figure 7).



Figure 7 - Upper Link Mount Hole Location

13. Draw a line perpendicular to the frame rail 1-3/4" from the upper link mount hole location in both directions. Draw another line 1" below the hole location parallel with the frame rail. Place the front upper link mount framerail doubler against the frame rail with the short edge of the hole pattern down. Line it up with your 3 location lines from the previous step and trace around the perimeter of the doubler plate (Figure 8).

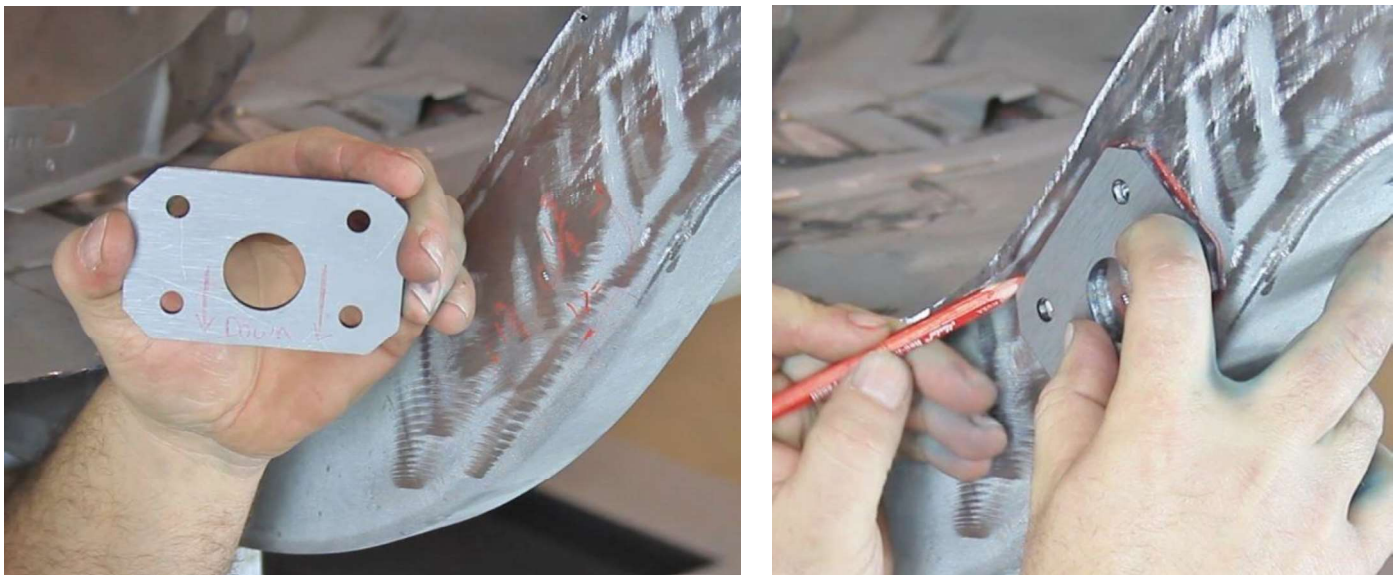

Figure 8 - Upper Link Mount Framerrail Doubler

14. Remove the doubler plate and drill a 1-1/4" hole at the upper link mounting hole location with a hole saw through the outside and inside frame rail. Place the frame rail doubler back in position on the outside frame rail and tack weld in place (Figure 9 on the next page).

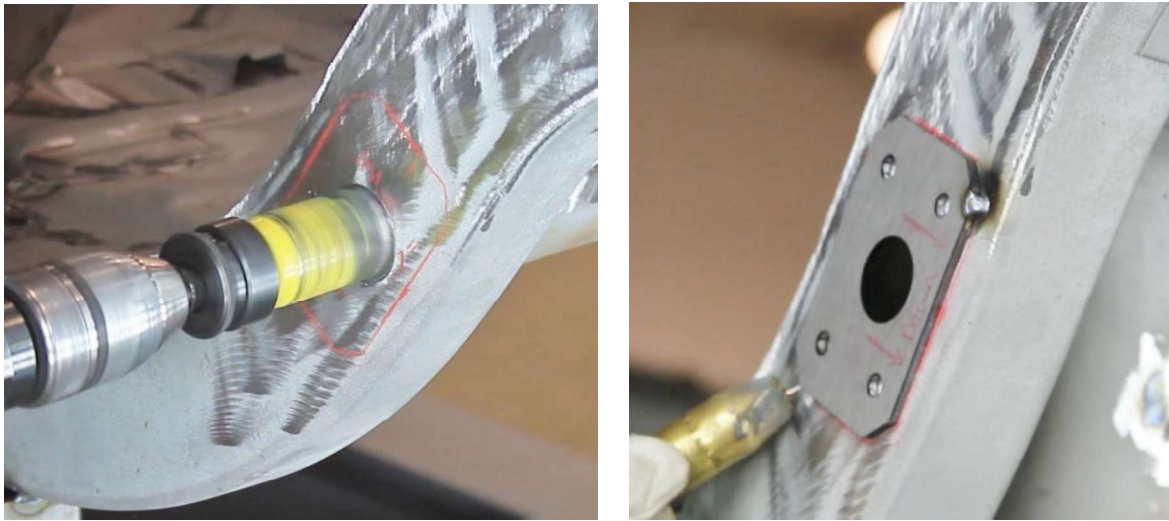

Figure 9 - Drill Upper Link Hole & Tack Weld Doubler Plate

15. Position the front upper link mount outer closeout bracket against the inside frame rail. Slide the provided 3" upper body side bracket crush tube through the outer closeout bracket, through the frame rail and through the frame rail doubler plate (Figure 10).



Figure 10 - Install Outer Closeout Bracket & Crush Tube

16. Locate the left and right hand front upper link mounting bracket. They will be stamped with an "L" and an "R". Position the upper link mounting bracket against the inside the frame rail and floor pan with the plug weld holes against the frame rail (Figure 11).



Figure 11 - Front Upper Link Mounting Bracket

17. Install the provided 9/16"-18 bolt through the crush tube. Install the provided 1" ID x 1" L spacer over the bolt on the inside of the frame rail against the upper link bracket and tighten with the provided 9/16"-18 hex nut and washer. Position the upper link bracket so it matches the profile of the bottom frame rail.

NOTE: Check the clearance with the upper Swivel Link to the floor pan. On some applications, you may need to pocket the floor pan to allow the front upper link mounting bracket to move forward in the vehicle, giving you clearance for the Swivel Link (Figure 12).



Figure 12 - Pocket Floor for Clearance

18. Clamp the upper link bracket against the frame rail and tack weld in place (Figure 13). Remove the 9/16" hardware and spacer, and plug weld the bracket to the frame rail at the pre-drilled holes. Do not fully weld around the perimeter of the bracket at this time. Repeat the upper link bracket installation on the opposite side of the vehicle.



Figure 13 - Tack Weld Upper Link Pocket

19. Install the provided 9/16"-18 x 7" L hex bolt and 2.42" L weld spacer through the frame rail crush tube and front upper link bracket. Install the 9/16"-18 hex nut and washer to hold the weld spacer in place. Perimeter weld around the upper link brackets. Loosen the 9/16"-18 bolt so it's out of the way and finish welding the bracket to the vehicle. Repeat this procedure for the opposite side of the vehicle.

20. Install the 3" upper body side bracket crush tubes through both frame rails. Measure across the inside of each crush tube. Position them so that they measure 34-7/16" apart from the inside of each crush tube. The same amount of crush tube should be through the inside of the frame rails (Figure 14). Once the crush tubes are in the correct location, tack weld them in place.

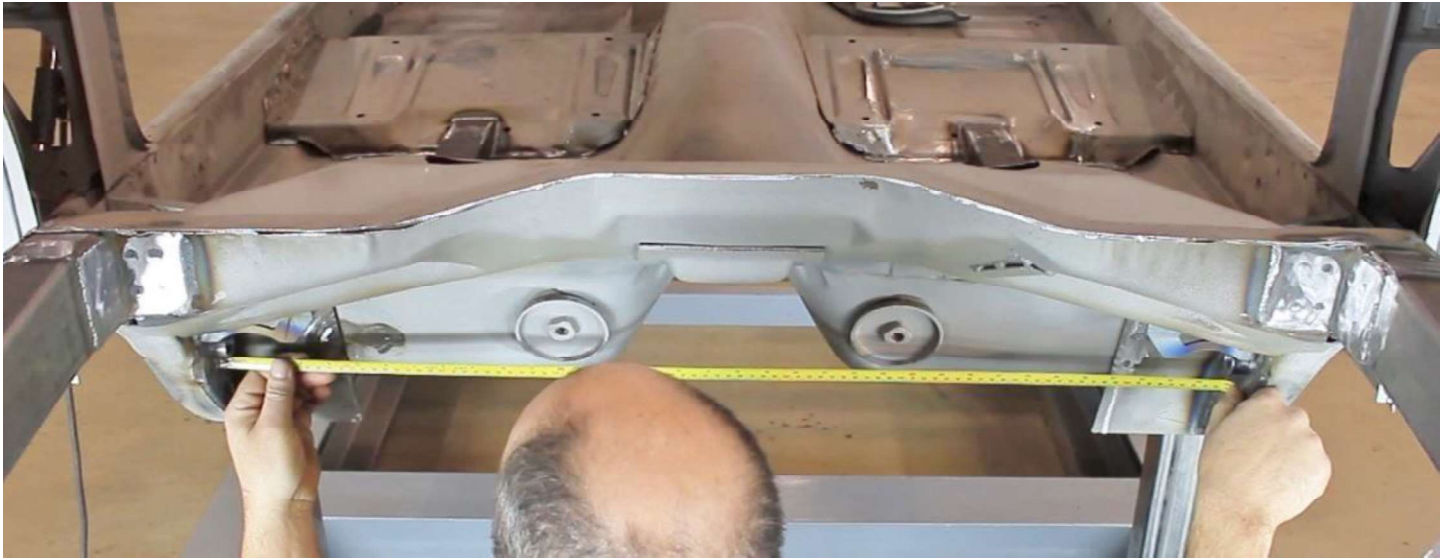

Figure 14 - Locate 3" Crush Tubes

21. Verify that you still have the correct measurement and finish weld them to the outer upper link mount bracket closeout. Using a cut-off wheel, remove the crush tube that is sticking past the outer frame rail so that it is flush to the frame rail doubler (Figure 15). Weld the crush tube to the frame rail doubler and grind smooth for a clean finish.



Figure 15 - Cut-Off Crush Tube Flush with Frame Rail

22. Install both QUADRALink front lower link mounting brackets into the torque boxes using the 1" OD x 3.0" L crush tubes. Install the 1/2"-20 x 7" L hex bolts, nuts and washers from the Detroit Speed Torque Box Kit and tighten (Figure 16 on the next page). Make sure the top surface of the link mount seats flat on the bottom of surface of the torque box.



Figure 16 - Locate Front Lower Link Bracket

23. Measure across the lower link mounting brackets and set them so they are $29\text{-}5/16$ " apart from the inside surface. With the lower link mounting bracket placed up against the torque box bottom plate, tack and finish weld the lower link mount to the crush tube. Install the 2.42" L weld spacer in the center hole of the link mount assembly. Plug weld and finish weld around the perimeter of the lower link bracket (Figure 17). Repeat this procedure for the opposite side of the vehicle.



Figure 17 - Weld Front Lower Link Bracket

24. Position the lower link closeout into the torque box (Figure 18) and tack and plug weld it in place. Finish weld around the perimeter of the closeout.



Figure 18 - Locate Lower Link Closeout

25. Cut and trim the frame closeout as necessary to properly fit between the back lower link mount surfaces and the front surface of the upper link mounting bracket. Level the closeout and weld it in place (Figure 19). Repeat this procedure for the opposite side of the vehicle.



Figure 19 – Trim and Weld Closeouts

26. Position the upper crossmember into the vehicle and trim as needed so that it sits down between the frame rails. Center the crossmember to the vehicle by measuring from the center of the original leaf spring hole to the bottom of the front edge at the back of the crossmember. The dimension should be $30\text{-}5/16$ " straight across or a horizontal dimension of $28\text{-}3/4$ " if you are using a plumb bob (Fig 20).

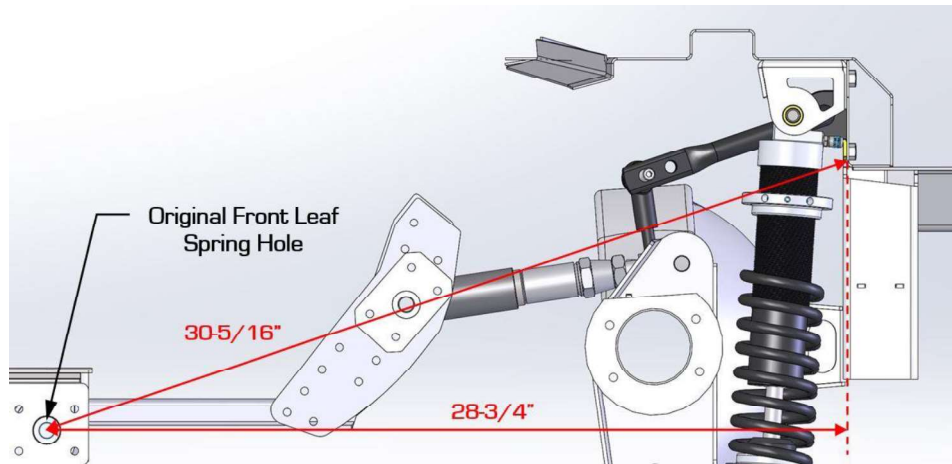

Figure 20 – Locate Upper Crossmember

27. With the crossmember centered and leveled in the vehicle, tack weld it to the frame rails (Figure 21). Finish weld the crossmember to the frame rails.



Figure 21 – Weld Upper Crossmember

28. Stitch weld the front edge of the crossmember to the original floor and trunk sheet metal from underneath and inside the vehicle (Figure 22).



Figure 22 - Stitch Weld Front of Crossmember

29. Measure between the inner frame rails to mark a centerline on the Sway bar crossmember (Figure 23). Draw a line 14-1/2" off the center line in both directions to locate the upper shock mounts.

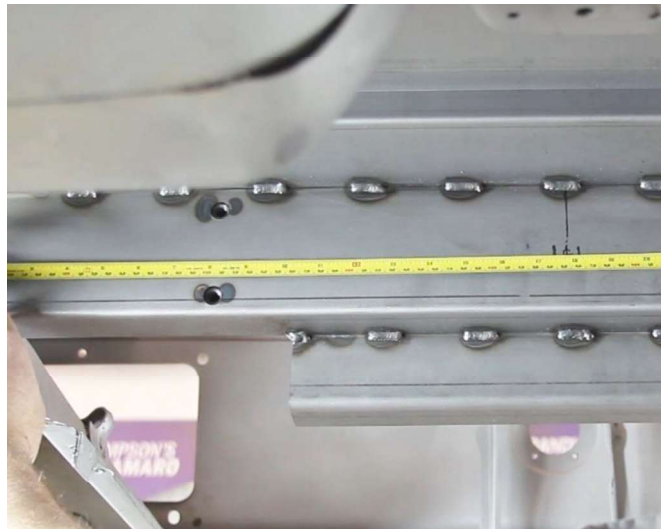

Figure 23 - Locate Centerline on Crossmember

30. Locate the left- and right-hand upper shock mount. The welded crush tube in the shock mounts should be to the outside of the vehicle. Place the upper shock mounts to the outside of the marked line. Position them square to the crossmember and tack weld them in place. Finish welding around the perimeter of the shock mounts to the crossmember (Figure 24).



Figure 24 - Weld Upper Shock Mounts

31. Use the provided templates to cut out the front trunk corners for exhaust clearance (Figure 25).



Figure 25 - Cut Out Front Trunk Corners

32. Fit and trim the front trunk corner closeouts and weld them in place (Figure 26). Once they are welded it is a good time to mock-up and fit the Detroit Speed fuel tank if available.

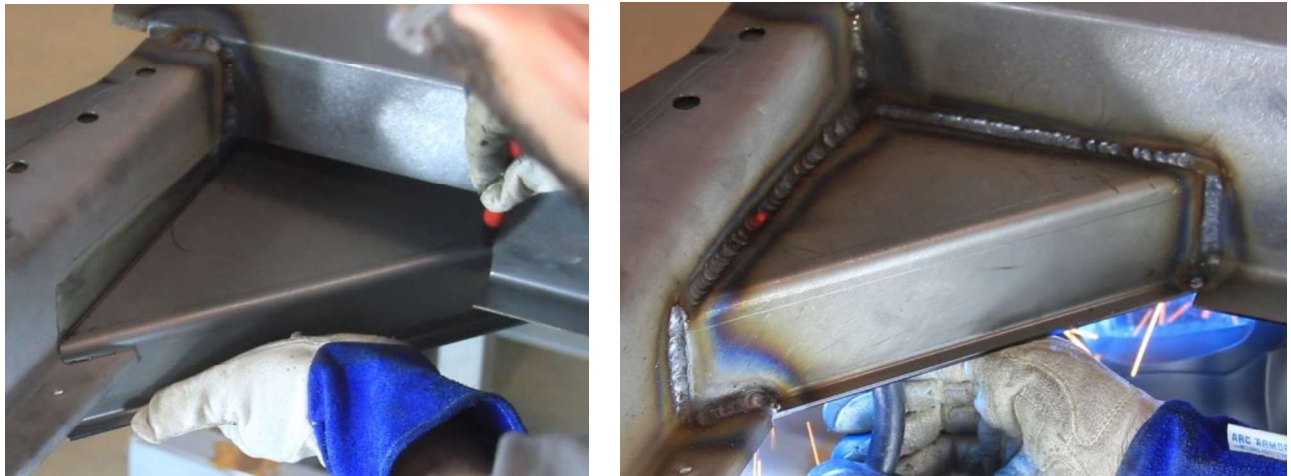

Figure 26 - Trim & Weld Front Trunk Closeouts

33. Scribe a trim line onto both ends of the crossmember that hang off past the frame rails. Cut this section of the crossmember so that it is flush with the outer frame rail (Figure 27). This will ensure a good fit when installing the Detroit Speed mini-tubs.

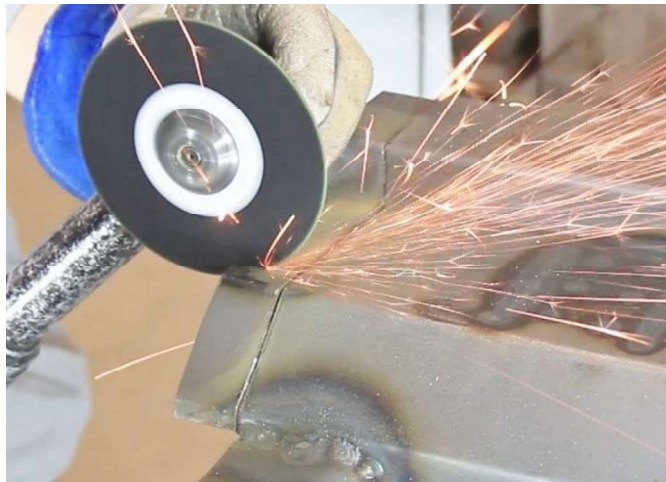

Figure 27 - Trim Upper Crossmember

34. Make a flat piece out of 18 gauge (.048") thick steel to close-out the upper crossmember to the inner frame rail face.
35. Position the track bar body bracket into place on the driver's side framerail. The top edges should sit flush with the driver's side framerail, trunk corner closeout and the back surface of the upper shocks crossmember. Level the bracket so it is perpendicular to the ground and tack weld in place (Figure 28). Verify that the track bar bracket is level and finish weld around the perimeter of the bracket.



Figure 28 – Weld Track Bar Body Bracket

36. At this point during the installation, the Detroit Speed Mini-Tubs can be installed into the vehicle at this time by continuing with the Mini-Tub instructions and video.
37. If you have purchased a rear end housing from Detroit Speed with the axle brackets already installed, the fabrication work is complete, and you can go to Step 47. If you are using a stock rear axle and will be replacing the housing ends, remove them from the axle tubes. Remove the factory leaf spring brackets from the axle tubes (Figure 29). Grind the factory welds on the axle tubes for a clean finish.

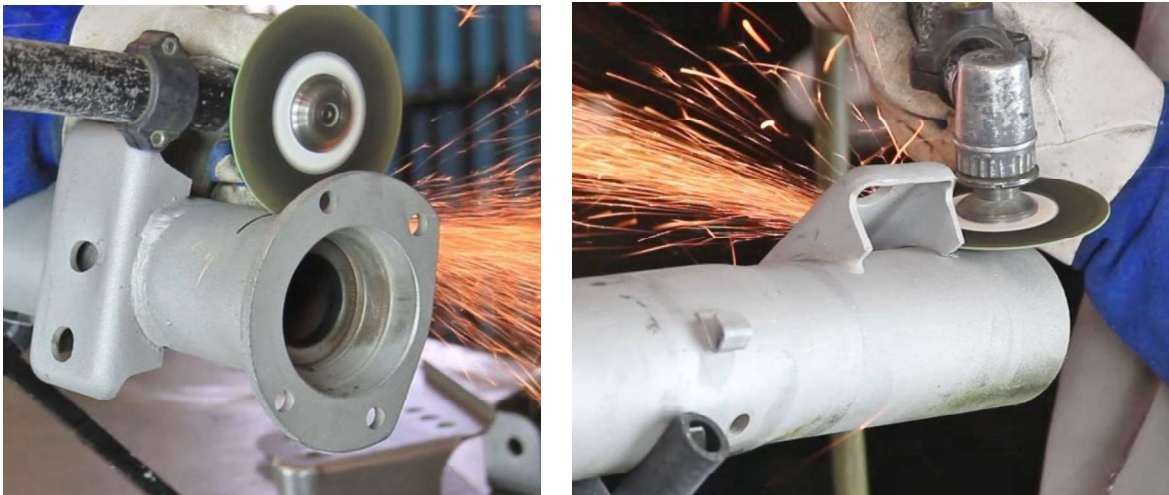

Figure 29 – Remove Housing Ends & Leaf Spring Brackets

38. Install the provided 2.42" L weld spacers into the axle bracket upper and lower link holes along with the provided 9/16"-18 bolts. Place the lower link/coilover axle bracket reinforcement onto the back of the axle bracket and weld in place (Figure 30 on the next page). Grind the axle bracket smooth for a clean finish.



Figure 30 - Weld Axle Bracket Reinforcement

39. Prepare the axle tubes to weld the axle bracket to the axle (Figure 31). **NOTE:** The Detroit Speed axle brackets are designed for a 3" axle tube, so if you have a stock axle housing, you will need to make an adapter ring since the stock axle tubes are smaller than 3" at one end.

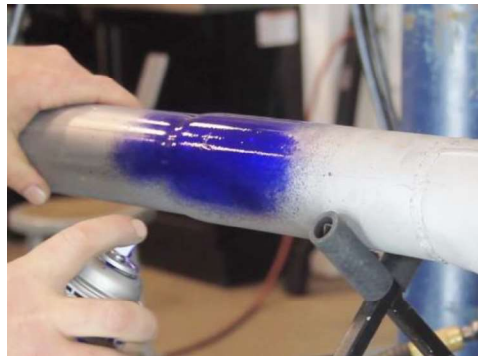

Figure 31 - Prepare Axle Tubes

40. Using a pinion centering tool, measure from the centerline of the rear axle outward $14\frac{5}{8}$ " in both directions and mark this location. This will be the location where the inside edge of the axle brackets will be positioned. Use the diagram in these instructions to locate the axle brackets on the axle housing (Figure 55). **NOTE:** Detroit Speed offers a pinion centering tool (P/N: 070202DS) that will be helpful in placing your axle brackets in the correct location on your axle tube. Draw a scribe line around the axle tube at the marked locations (Figure 32).



Figure 32 - Locate Axle Brackets on Axle Tubes

41. Install the axle brackets over the axle tubes and position the inside flange of the brackets at the scribed circle on the axle tubes. Clamp the rear axle in place on a bench. Rotate the housing forward so that the center section mounting flange is 4° down from vertical (Figure 55). Install the 2.42" L weld spacers into the upper link holes along with the 9/16"-18 bolts (Figure 33).

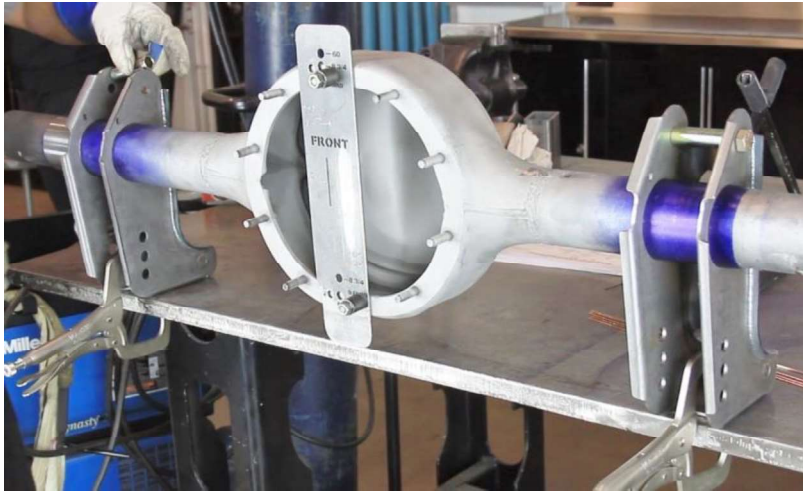

Figure 33 - Install Axle Brackets

42. Once the axle brackets are in the correct location, tack weld them to the axle tubes. Verify the correct location and then finish weld all the way around the brackets to the axle tubes (Figure 34).



Figure 34 - Weld Axle Brackets

43. Install the track bar axle bracket up against the outboard side of the right-hand axle bracket. Verify that it is 90° to the axle tube and tack weld them in place (Figure 55). Verify that the bracket fits tight to the axle bracket and around the axle tube and finish weld (Figure 35).

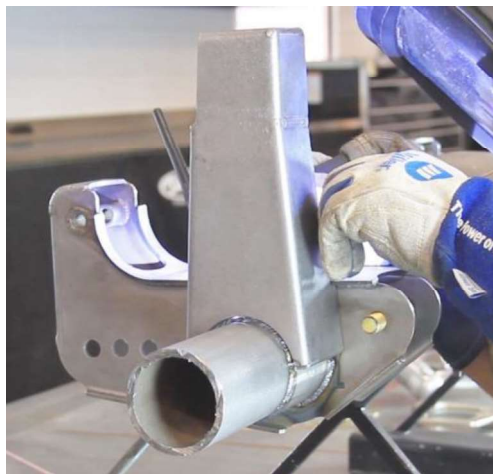

Figure 35 - Weld Track Bar Bracket

44. Position the sway bar endlink brackets so that the 90° gusset fits up against the inside flange of the axle brackets. Locate the bracket so the endlink hole is centered on the axle tube (Figure 55). Tack weld each bracket and then verify the correct location before finish welding (Figure 36).

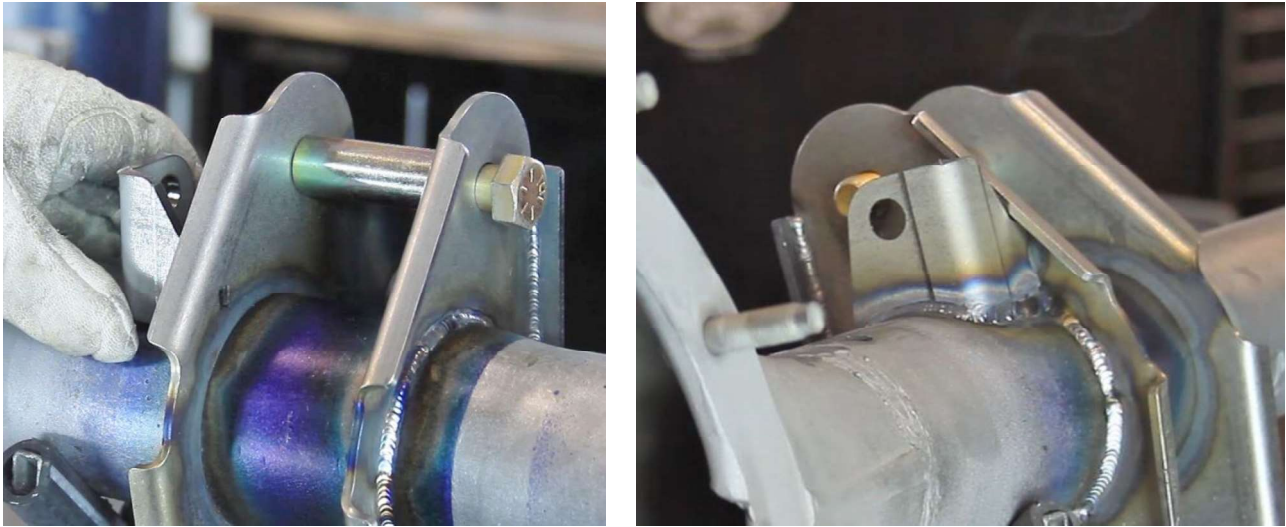

Figure 36 - Weld Sway End-Link Brackets

45. At this point the fabrication work is complete. Send the axle to a qualified shop to have the housing ends welded (if necessary). Check the axle tubes and have them straightened (if necessary).

46. Mocking up the vehicle before painting all the components is recommended. Mockup includes installing all the suspension components (link bolts still don't need to be tightened yet), installing the wheels/tires, and resting the vehicle on all four tires.

47. Install the upper Swivel Links into the upper link pockets with the provided 9/16"-18 x 7" L hex bolts, Nylock nuts and washers on both sides of the vehicle. Place the provided 1/2" thick aluminum upper link spacers into the upper link pockets on the inboard side of the Swivel Links.

48. Install the lower Swivel Link into the lower link pocket with the provided 9/16"-18 x 3-3/4" L hex bolts, Nylock nuts and washers on both sides of the vehicle (Figure 37). The middle hole in the lower link bracket will be the nominal setting (Figure 45).



Figure 37 - Install Upper & Lower Links

49. Slide the provided polyurethane bushings onto the rear sway bar. Install the sway bar mounting brackets over the polyurethane bushings. Place the sway bar up to the mounting holes in the crossmember and install the provided 3/8"-16 x 1" L hex bolts and washers into the weld nuts in the crossmember (Figure 38). Use blue Loctite on the threads and torque the bolts to 30 ft-lbs.



Figure 38 - Install Sway Bar

50. Next, it is necessary to build each coilover shock and spring assembly before installing them into the vehicle.

51. Remove the upper spring seat from the retaining ring using a rubber hammer and moving it down off the upper shock mount (Figure 39). Remove the retaining ring from the upper shock mount and pass the upper spring seat over the upper shock mount (Figure 40).



Figure 39 - Removing the Upper Spring Seat



Figure 40 - Upper Spring Seat & Retaining Ring

52. Thread the spanner nut all the way to the bottom of the coilover shock and install the Torrington bearing set (Figure 41) on each shock by installing one thrust washer, followed by the roller bearing and then another thrust washer. Detroit Speed recommends using high pressure grease between the roller bearing and thrust washers.



Figure 41 - Torrington Bearing Set

53. Slide the coilover spring over the top of the upper shock mount. Install the upper spring seat back over the top of the upper shock mount and re-install the retaining ring back onto the upper shock mount. Press the upper spring seat up onto the retaining ring so it locks in place.
54. Install the shock and spring assembly into the upper shock mounts with the shock body up. Install the provided 3/4" long spacers onto the 1/2"-20 x 3" L hex bolts and install through the inside of the upper shock mount and through the monoball in the shock. Use anti-seize on the threads of the bolts and install the 1/2"-20 Nylock nuts and washers (Figure 42). **NOTE:** The Schrader valve should be pointing towards the front of the vehicle. If you have adjustable shocks, the adjustment window should be facing towards the back of the vehicle.

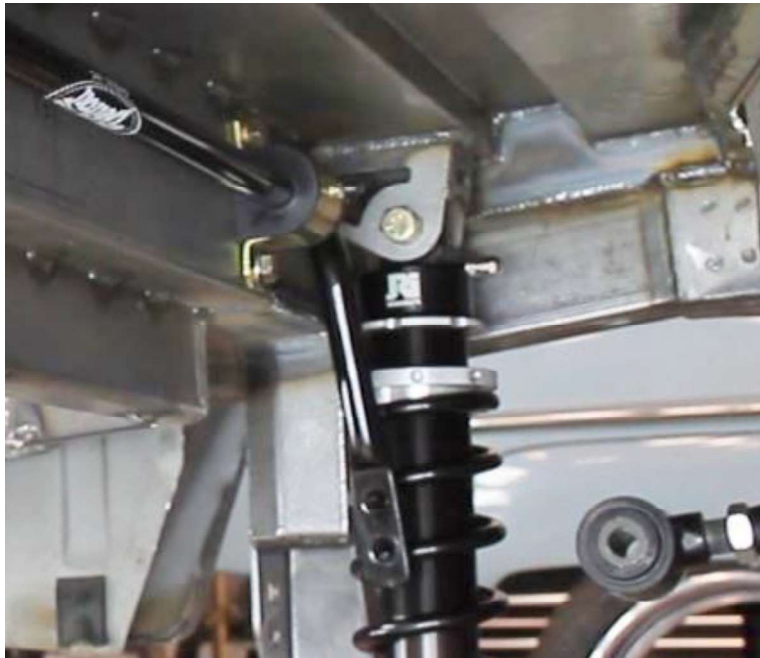

Figure 42 - Install Coilover Shock and Spring Assembly

55. Position the rear axle underneath the vehicle. Before the rear axle is installed into the vehicle, install the Sway bar endlinks into the housing brackets. Set the endlinks to 3-1/4" center to center and mount the female end to the axle bracket (Figure 43).



Figure 43 - Install Sway Bar End-Links onto Axle Brackets

56. Install the upper and lower Swivel-Links into the rear axle brackets using the provided 9/16"-18 x 3-3/4" L hex bolts, Nylock nuts and washers on both sides of the vehicle (Figure 44 on the next page). Install the lower links into the middle hole in the axle bracket as this will be your nominal setting (Figure 49).



Figure 44 - Install Upper & Lower Links

57. Install the coilover shocks into the axle brackets with the provided 1/2"-20 x 3-1/2" L hex bolts, Nylock nuts and washers. Use anti-seize on the threads of the bolts. (Figure 45).

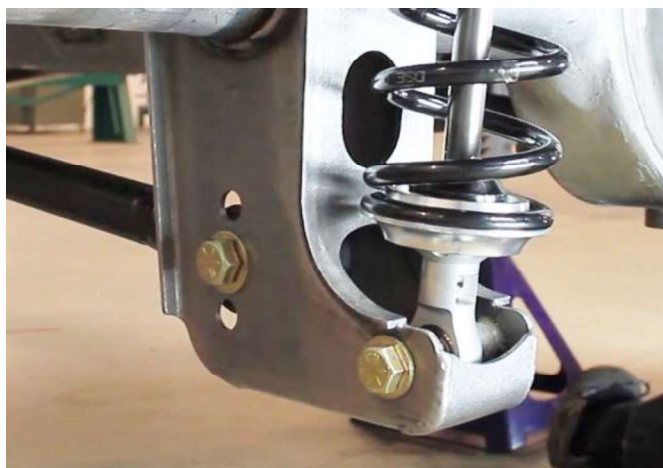

Figure 45 - Install Coilover Shocks

58. Install the sway bar endlinks on the rear axle into the front hole of the sway bar with the provided hardware (Figure 46).



Figure 46 - Attach Sway Bar End-Links

59. Install the track bar into the axle bracket and then the body sidetrack bar bracket with the provided 9/16"-18 x 3-3/4" L hex bolts, Nylock nuts and washers (Fig. 47). The nominal position for the track bar is the bottom hole on the body mounting bracket. The track bar should be level at ride height.



Figure 47 - Install Track Bar

60. Support the axle at ride height. Nominal ride height is 15" from center to center of the coilover shock mounting bolts. Check the axle position in the vehicle and adjust the links as necessary. **NOTE: There can be no more than 2" of exposed threads on the end link (3/4" of thread engagement in the tube). This measurement does include the jam nut (Page 28).**

61. The rear axle should be centered from side to side by adjusting the length of the track bar. The pinon angle should be measured and adjusted with the upper links to your preference. Detroit Speed recommends 4° down. The wheelbase should be measured and adjusted with the lower links. **NOTE: 108.0" is the correct wheelbase for a 1964.5-70 Mustang.**

62. Raise and lower the vehicle to verify that there is no interference. Now is a good time to install the exhaust system. Paint or powdercoat the components as desired.

63. Upon final assembly see the table below for the correct torque settings for the QUADRALink rear suspension hardware (Figure 48).

Fastener Torque Specifications - Detroit Speed Mustang QUADRALink		
Application	Torque (ft-lb)	Threads
Lower Link Mount Assembly	75	Anti-Seize
Sway Bar Link Nuts	45	
Coilover Shock Mounting Bolts	60	Anti-Seize
Sway Bar Mounting Bolts	30	Blue Loctite 242
Swivel-Link & Track Bar Bolts	120	
Swivel-Link & Track Bar Jam Nuts	100	
Rear Brake Caliper Mounting Bracket Bolts	125	Red Loctite 272
Wheel Stud Nuts	100	

Figure 48 - Rear Suspension Torque Specifications

64. Reinstall the fuel tank, fuel lines and interior components that were removed. Install the wheels and lower the vehicle to the ground. Verify that the track bar is installed in the hole that places it closest to horizontal (nominal design is the lower hole in the bracket).

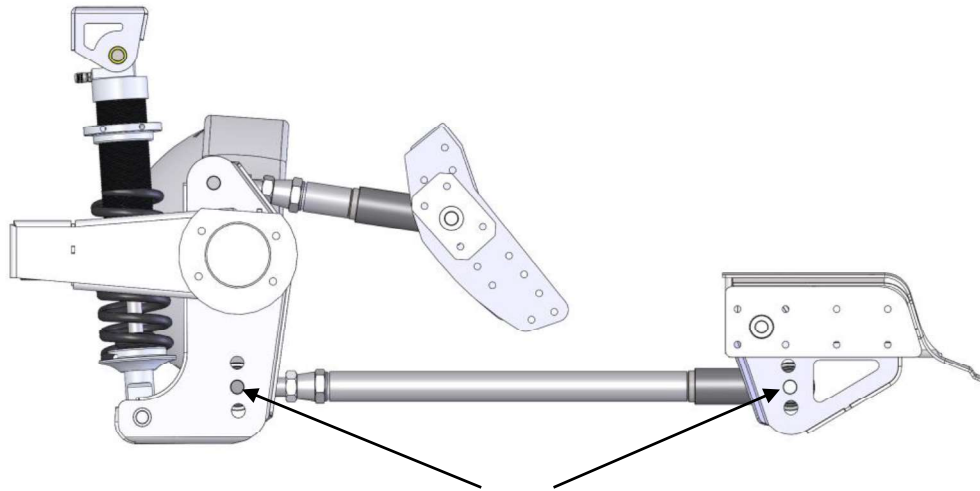

Nominal Position Shown
 Instant Center: 55.8" Forward of Rear Axle Centerline
 7.5" Above Ground Level

* *See chart below for adjustment info* *

Lower Link Adjustment Settings

Axle Bracket Position	Body Bracket Position	Instant Center	Notes
Bottom Hole	Top Hole	40.5" / 9.8"	Frame must be modified
Bottom Hole	Middle Hole	48.5" / 8.6"	
Bottom Hole	Bottom Hole	60.4" / 6.8"	
Middle Hole	Top Hole	44.5" / 9.2"	
Middle Hole	Middle Hole	55.8" / 7.5"	Detroit Speed Nominal Setting
Middle Hole	Bottom Hole	75.0" / 4.6"	
Top Hole	Top Hole	51.0" / 8.2"	
Top Hole	Middle Hole	69.4" / 5.5"	
Top Hole	Bottom Hole	108.3" / -0.3"	

Instant center numbers are expressed as distance forward of rear axle centerline, then height above ground level.

Figure 49 - Lower Link Adjustment Settings

- 65. Confirm the rear axle position again and double check that all the bolts and jam nuts are tightened to their respective torque specifications.
- 66. With the vehicle assembled with all the components installed, adjust the ride height as necessary. Detroit Speed does recommend using a small wipe of anti-seize before adjusting the spanner nut and compressing the coilover spring.
- 67. Detroit Speed does include a Spanner Tool (P/N: 031060DS) to adjust ride height however if you have the adjustable coilover shocks, Detroit Speed does offer an Adjustment Tool available as P/N: 031061DS if needed. A photo can be seen in Figure 50.



Figure 50 - Detroit Speed Spanner & Adjustment tools

68.If the Single Adjustable, Double Adjustable or the Double Adjustable Remote Canister Coilovers were purchased as an upgrade, refer to the following information for adjustment procedures.

PLEASE NOTE: ALL ADJUSTABLE TYPE SHOCKS GET MOUNTED BODY SIDE UP SHAFT SIDE DOWN

Detroit Speed Single Adjustable Shock Applications

To change from the recommended “Detroit Tuned” valving, adjustments can be made independently to the rebound setting. The rebound is controlled by the knob at the lower shock mount (Shock is mounted body side up). The knob rotates clockwise (+) to increase the damping and counterclockwise (-) to decrease the damping. Refer to Figure 51a below.

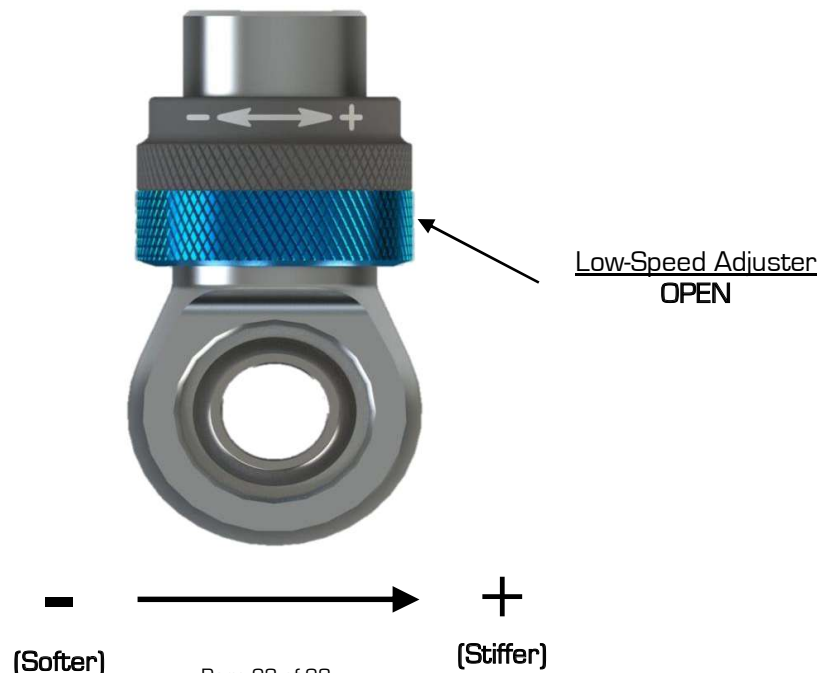

Figure 51a- Detroit Speed Single Adjustable Shock

To return to the Detroit Speed recommended settings, turn the knob clockwise (+) to full damping. Once at full damping, turn counterclockwise (-) to reach the recommended settings. Refer to Figure 51b for the recommended starting setting.

Rebound (Shaft Knob) 20 Open [counterclockwise, -]
Figure 51b - Detroit Speed Recommended Settings

Adjuster Operation



- **Adjuster (60-64 Clicks)**

The low-speed adjuster is a “clicker” style adjuster meaning that its adjustment is measured by detents located inside the blue adjuster knob. There are 16 clicks per one revolution of the knob. It uses a right-hand thread in its operation which means as you increase low speed, the adjuster will move up on the eyelet. The recommended change for an adjustment is 8 clicks at a time. The low-speed adjuster’s reference position is **full stiff** (closed, or all the way up) and referred to -0 (-0 = full stiff, -64 = full soft).

- **Tuning Notes**

- **Racetrack**

- For more grip, soften the damping.
- For increased platform control, stiffen the damping.

- **Street**

- For a more comfortable ride, soften the damping

***DO NOT FORCE KNOB WHEN IT STOPS TURNING, YOU MAY DAMAGE THE ADJUSTER AND INTERNAL HARDWARE**

Detroit Speed Double Adjustable Shock Applications

To change from the recommended “Detroit Tuned” valving, adjustments can be made independently to both the high and low speed settings. The rebound is controlled by the sweepers at the lower shock mount. The sweepers rotate clockwise (+) to increase the damping and counterclockwise (-) to decrease the damping. The sweepers can be seen in Figure 52a on the next page.



Figure 52a - Detroit Speed Double Adjustable Shock

When adjusting the low speed rebound start at full (+) position, when adjusting the high speed rebound start at full (-) position. To return to the Detroit Speed recommended settings turn the sweeper clockwise (+) to full damping for the low-speed setting, and counterclockwise (-) to full damping for the high-speed setting. Once at full damping, turn counterclockwise (-) for the low-speed setting, and clockwise (+) for the high-speed setting to reach the recommended settings. Refer to Figure 52b for recommended starting settings.

- Low Speed Rebound (Sweeper)..... 20 sweeps (counterclockwise, -)
- High Speed Rebound (Sweeper)..... 2 sweeps (clockwise, +)

Figure 52b - Detroit Speed Recommended Settings

Detroit Speed Double Adjustable Shocks w/Remote Canisters

To change from the recommended “Detroit Tuned” valving, adjustments can be made independently to both the high and low speed settings. The rebound is controlled by the sweepers at the lower shock mount. The sweepers rotate clockwise (+) to increase the damping and counterclockwise (-) to decrease the damping. Refer to Figure 53a.



Figure 53a – Detroit Speed Double Adjustable Shock w/ Remote Canister

When adjusting the low speed rebound start at full (+) position, when adjusting the high speed rebound start at full (-) position. To return to the Detroit Speed recommended settings turn the sweeper clockwise (+) to full damping for the low-speed setting, and counterclockwise (-) to full damping for the high-speed setting. Once at full damping, turn counterclockwise (-) for the low-speed setting, and clockwise (+) for the high-speed setting to reach the recommended settings. Refer to Figure 53b for recommended starting settings.

Low Speed Rebound (Sweeper)..... 20 sweeps (counterclockwise, -)
 High Speed Rebound (Sweeper)..... 2 sweeps (clockwise, +)

Figure 53b – Detroit Speed Recommended Settings

Adjuster Operation

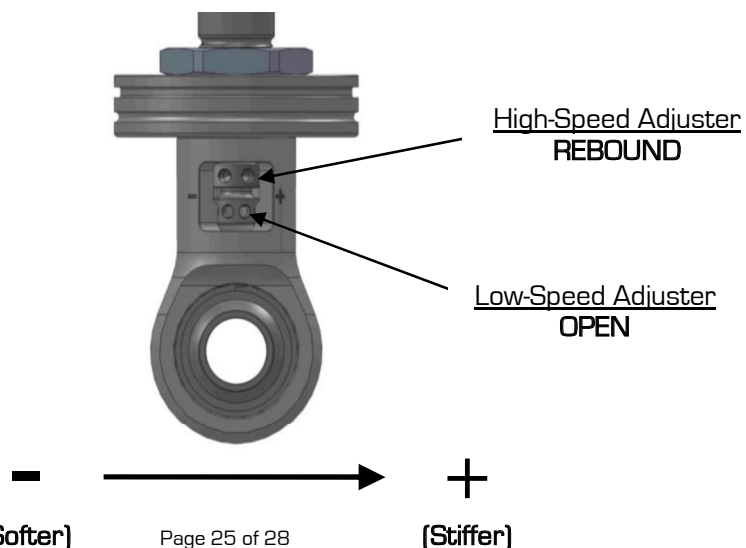

- **High-Speed Adjuster (12 Sweeps)**

The high-speed adjuster is a “sweep” style adjuster meaning that its adjustment is measured by the location of the adjuster in the eyelet window. It uses a left-hand thread in its operation which means; as you increase high-speed, the adjuster will move down in the window*. The high-speed adjuster’s reference position is **full soft** and referred to as +0 (+0 = full soft, +12 = full stiff).

- **Low-Speed Adjuster (25 Clicks)**

The low-speed adjuster is a “clicker” style adjuster meaning that its adjustment is measured by detent grooves located inside the high-speed shaft. It uses a right-hand thread in its operation which means; as you increase low speed, the adjuster will move up in the window. The low-speed adjuster’s reference position is **full stiff** and referred to as -0 (-0 = full stiff, -25 = full soft).

**The low-speed adjustment does not change when adjusting the high-speed.*

To aid in the installation of the reservoirs, we also offer a set of Billet Aluminum Remote Canister Mounts. The canister mounts are available exclusively through Detroit Speed, P/N: 032102DS. They are shown below in Figure 54.



Figure 54 - Billet Aluminum Remote Canister Mounts

If you have any questions before or during the installation of this product, please contact Detroit Speed at tech@detroitsspeed.com or 704.662.3272.



SPEED & ENGINEERING

**1960-65 FALCON/COMET QUADRA-LINK
1964.5-1970 MUSTANG QUADRA-LINK
AXLE BRACKET LOCATIONS**

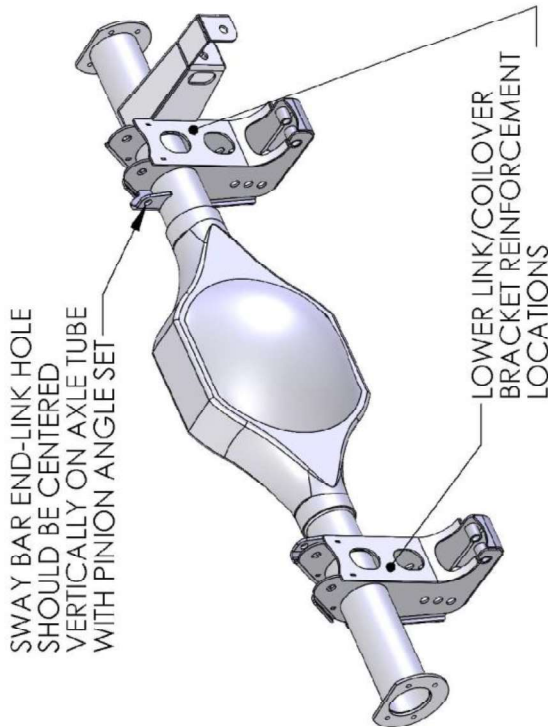

TOP VIEW

THIS SURFACE SHOULD BE PERPENDICULAR TO AXLE CENTERLINE

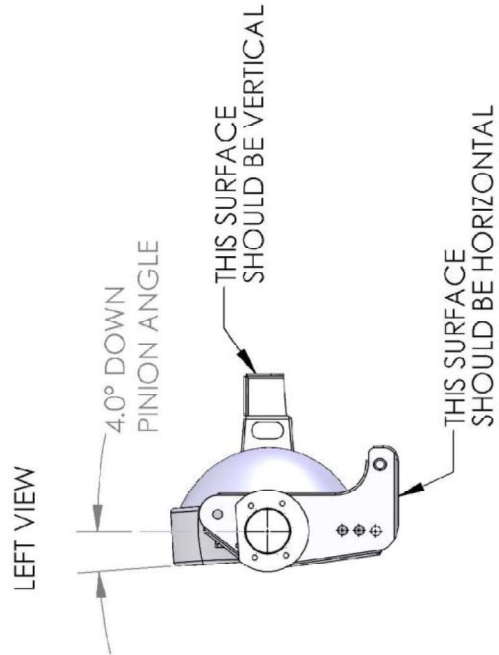
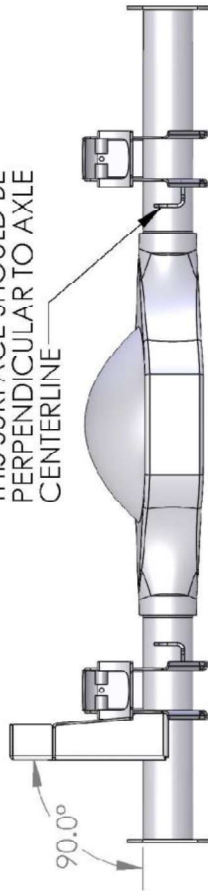

LEFT VIEW

4.0° DOWN PINION ANGLE

THIS SURFACE SHOULD BE VERTICAL

THIS SURFACE SHOULD BE HORIZONTAL

FRONT VIEW

PINION CENTER AXLE/CAR CENTERLINE

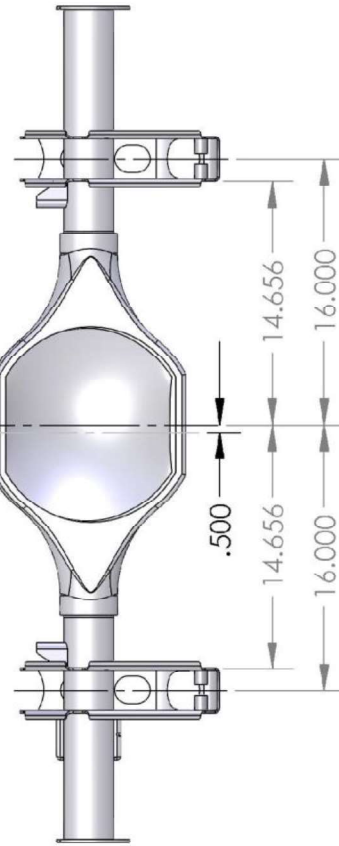

***NOTE THAT THE CENTERLINE OF THE AXLE IS NOT LOCATED AT THE CENTER OF THE PINION, AND DEPENDING ON AXLE TYPE, MAY NOT BE LOCATED AT THE CENTER OF THE CARRIER HOUSING. THE PINION IS OFFSET TO THE PASSENGER SIDE OF THE VEHICLE. DSE USES 1/2" OFFSET.**

Figure 55 - Axle Brackets

Once again, we appreciate your business.

If you have any questions during the installation of this product, call (704) 662-3272.



Detroit Speed
Swivel-Links

WARNING:

There can be no more than 2" of exposed threads on the end link (3/4" of thread engagement in the tube). This measurement does include the jam nut (see below).

