

## Detroit Speed

P/N: 032041DS, 032041-SDS, 032041-DDS, 032041-RDS, 032043DS, 032043-SDS, 032043-DDS, 032043-RDS, 032045DS, 032045-SDS, 032045-DDS, 032045-RDS, 032047DS, 032047-SDS, 032047-DDS, 032047-RDS, 032060DS & 032062DS

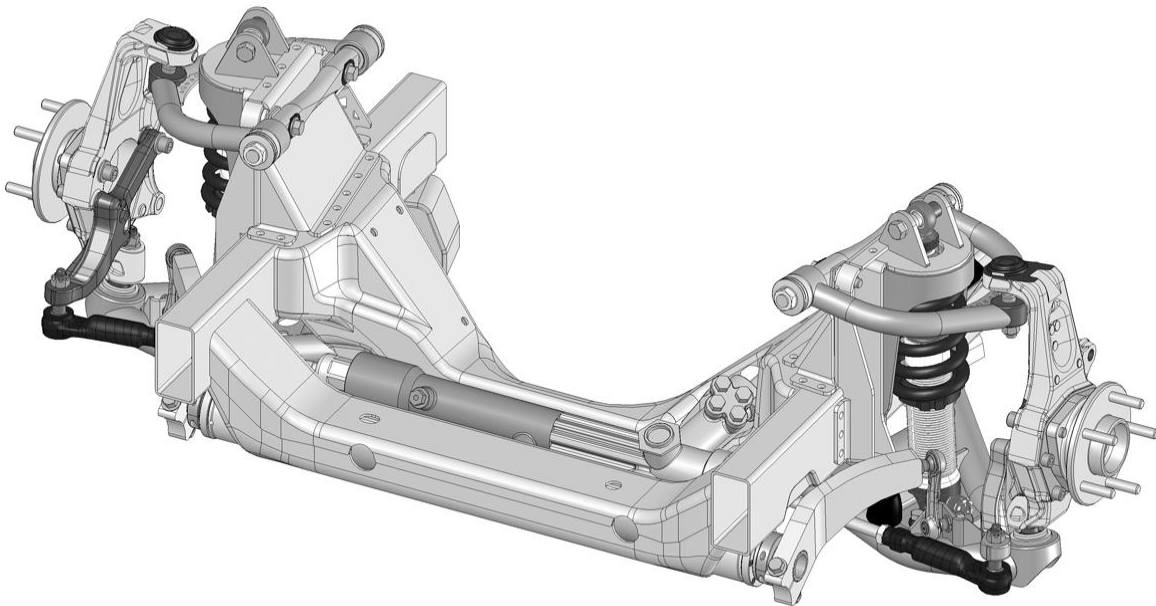

Detroit Speed's X-Gen Series of front suspension systems allow you to integrate Detroit Speed suspension technology into any vehicle. These complete suspension modules are available in two track widths and are ready to be stubbed into your application through their 2" x 4" rail sections. These are the same suspension systems found in Detroit Speed's bolt-in front frames, so they have been designed, engineered, and developed to provide the ultimate in ride quality and performance on both the road and the track.



The Detroit Speed X-Gen 535 Frame has the following features:

- OEM quality stamped crossmembers for improved structural rigidity
- Detroit Speed exclusive suspension geometry for superior ride and handling
- Aluminum body coilover shocks with "Detroit Tuned" valving
- Integrated splined anti-roll bar
- Caster tuner bushings which allow independent caster/camber adjustments
- Detroit Speed Exclusive 'Detroit Tuned' power rack and pinion steering



NOTE: There is an installation video available through the Detroit Speed website in the tech/install video section shown here: <https://www.detroitsspeed.com/x-gen-installation-videos>.

**CAUTION:** The Detroit Speed X-Gen frame requires advanced skills to install. For optimum performance, all work should be done by a highly qualified welder and technician. If you have any questions, please contact Detroit Speed, Inc. at (704) 662-3272

Specifications - Detroit Speed X-Gen 535	
Total Suspension Travel	6"
Ride Height*	1.5" ± 1.0"
Static Camber	- 0.5° ± 0.2°
Static Caster	+7.0° ± 0.5°
Static Toe	0.0° ± 0.1°
*Measured from the top of the framerail to the center of the hub	

Engine Fitment - Detroit Speed X-Gen 535				
SBC Engines				
Engine	Mounting	Oil Pan	Headers	Comments
Small Block Chevrolet	DSE Engine Mounting Kit P/N 060415	CALL	DSE Headers P/N 061003 & 061004	
LS Engines				
Engine	Mounting	Oil Pan	Headers	Comments
LS1, LS2, LS3, LS7* & LS9	DSE Engine Mounting Kit P/N 060416	CALL	DSE Headers P/N 061002	

NOTE: A/C compressor will need to be relocated to the top of the LS engine to clear the crossmember. Use Holley or Vintage Air front drive system.

\*NOTE: For aftermarket LS engines (i.e., Mast Motorsports), refer to manufacturer for specific oil pan usage and use chart above for correct DSE Mounting Kit.

Accessory Components - Detroit Speed X-Gen 535	
Brakes	DSE has Baer brake packages available. Any C6 Corvette brake will work with this application.
Rack & Pinion Fittings	Return (low): 5/8" - 18 - Pressure (high): 9/16" - 18 Fittings to adapt to -6 AN and complete hose kits are available from DSE depending on your application
Rack & Pinion Input Shaft	3/4"-36, 092503DS Plain Steel, 092503PDS Polished Stainless
Wheel Stud Kit (Optional)	ARP 100-7708 - M12-1.5 x 2.5" L GM Wheel Stud Kit

Due to the universal nature of the X-Gen frame series, Detroit Speed does not include springs in this kit. Use the following chart on the next page as a guide for determining the correct spring rate for your application. Detroit Speed can help you with your springs or any other questions you have.



Spring Rates - Detroit Speed X-Gen 535		
Front Axle Weight (lbs.)	Spring Rate (lbs/in)	Spring Length (in)
1500-1700	300	10
1701-1900	400	10
1901-2100	500	10

Due to the universal nature of the X-Gen frame, appropriate wheel fitment can vary greatly from the following guidelines for your application. Detroit Speed advises installing the frame and then carefully measuring for the appropriate wheel size for your application before ordering wheels.

Wheel Fitment - Detroit Speed X-Gen 535					
Diameter (in)	Width (in)	Backspacing * (in)	Bolt Pattern/ Lug Nut Thread Pitch	Recommended Tire	Comments
17	8.0	4.75	5 X 4.75"/ M12x1.5	245/40R17	
	8.5			245/40R17	
	9.0			255/40R17	
18	8.0	5.00		245/35R18	
	8.5			245/35R18	
	9.0			255/35R18	
	9.5			265/35R18	

\* Listed backspacing values are the maximum for front suspension tie rod clearance.

\* 17" wheels require a minimum inside wheel diameter of 16.250"

**Caution:** Some brake applications will not work with 17" wheels. Flush mount valve stems may also be required on wheels with a behind center valve stem location.

Fastener Torque Specifications - Detroit Speed X-Gen 535		
Application	Torque (ft-lb)	Threads
Lower Control Arm Mounting Bolts	95	Anti-Seize
Rack and Pinion Mounting Bolts	95	Anti-Seize
Anti-Roll Bar Support Screws	20	
Anti-Roll Bar Shaft Clamp Screw	14	Blue Loctite 242
Anti-Roll Bar Link Nuts	45	Red Loctite 262
Upper Control Arm Cross Shaft Mounting Bolts	75	Red Loctite 262
Upper Coilover Shock Mounting Bolts	60	Anti-Seize
Lower Coilover Shock Tie Bar Bolts	35	Anti-Seize
Anti-Roll Bar Arm Mounting Bolt	25	Anti-Seize
Tie Rod End Jam Nut	45	Anti-Seize
Upper Control Arm Ball Joint Stud Nut	40	
Lower Control Arm Ball Joint Stud Nut	20 then turn an additional 180°	Red Loctite 262
Tie Rod End Stud Nut*	35	Anti-Seize
Wheel/Hub Bearing Mounting Bolts	95	Red Loctite 262
Steer Arm Mounting Bolts	60	Red Loctite 262
Front Brake Caliper Mounting Bracket Bolts	125	
Wheel Stud Nuts	100	

\* Always tighten slotted nuts to line up with the cotter pin hole when applicable.

## **IMPORTANT:**

1. If you have purchased the bare metal, X-Gen 535 front suspension module, the upper and lower control arms **CANNOT** be powder coated since they come already assembled from Detroit Speed. The temperatures from this process will destroy the control arms beyond repair.

The Detroit Speed upper control arms **CANNOT** be taken apart because of the precise assembly procedure at DSE. The upper control arm cross shaft nuts are torqued and then pinned in place. Failure to follow the correct procedure will damage the upper control arms beyond repair. Any attempt at taking apart any of the Detroit Speed subframe components before calling DSE will void any warranty. If you have any questions, please call Detroit Speed at 704-662-3272.

2. If the lower control arm ball joint stud needs to be serviced after the initial torque setting listed above for a coilover spring change, etc. use the following information to re-assemble the lower control arm and upright:
  - a) Before you remove the ball joint nut, make a line with a marker from the top of the nut down to the upright and then loosen the ball joint nut.
  - b) Upon re-assembly, torque the ball joint nut to 20 ft-lbs. and then tighten the nut until the line on the nut goes back to the line on the upright so it is back in the same location as the initial torque setting.
3. If the upper ball joint needs to be replaced, the Detroit Speed upright assembly must be returned to DSE to be serviced. Failure to follow this procedure before calling Detroit Speed will void any warranty. If you have any questions, please call at 704-662-3272.

## Locating the Frame

1. Before disassembling the car, set the car at ride height and locate the wheel centerline vertically and horizontally on the original frame. Modifying this wheel centerline affects final ride height and wheelbase, so if you wish to modify these parameters, adjust the wheel centerline appropriately. Example: for a two-inch final drop, adjust the vertical position of the wheel centerline up two inches.
2. Detroit Speed also recommends recording the location and height of the mounting points of all other frame-mounted components, i.e., bumper bolts, body mounts, radiator support, etc. so that they can be properly located after installing your new frame section.
3. Create a fixture or jig that will allow you to match the wheel centerline of your new X-Gen frame to the original (or modified) wheel centerline. The jig can also be built to locate other frame-mounted components for greater assurance that the final frame location is correct.
4. Remove all the forward bodywork, front suspension, drivetrain, and any accessories from the front section of the vehicle. Measure and remove the necessary front section of the factory frame, taking care to ensure that the desired wheel centerline can still be located once the frame has been removed.

- The wheel centerline of the X-Gen frame at designed ride height is located 12.75 inches from the rear edge of the attached frame rail section and 1.5 inches from the top of the frame rail with  $\pm 1$  inch of ride height adjustability. See Figure 1. The overall length of the frame rail section is 25.250". Carefully locate the new frame so that the X-Gen frame wheel centerline matches your desired wheel centerline location. Ensure that the frame is level and square to the body of the vehicle.

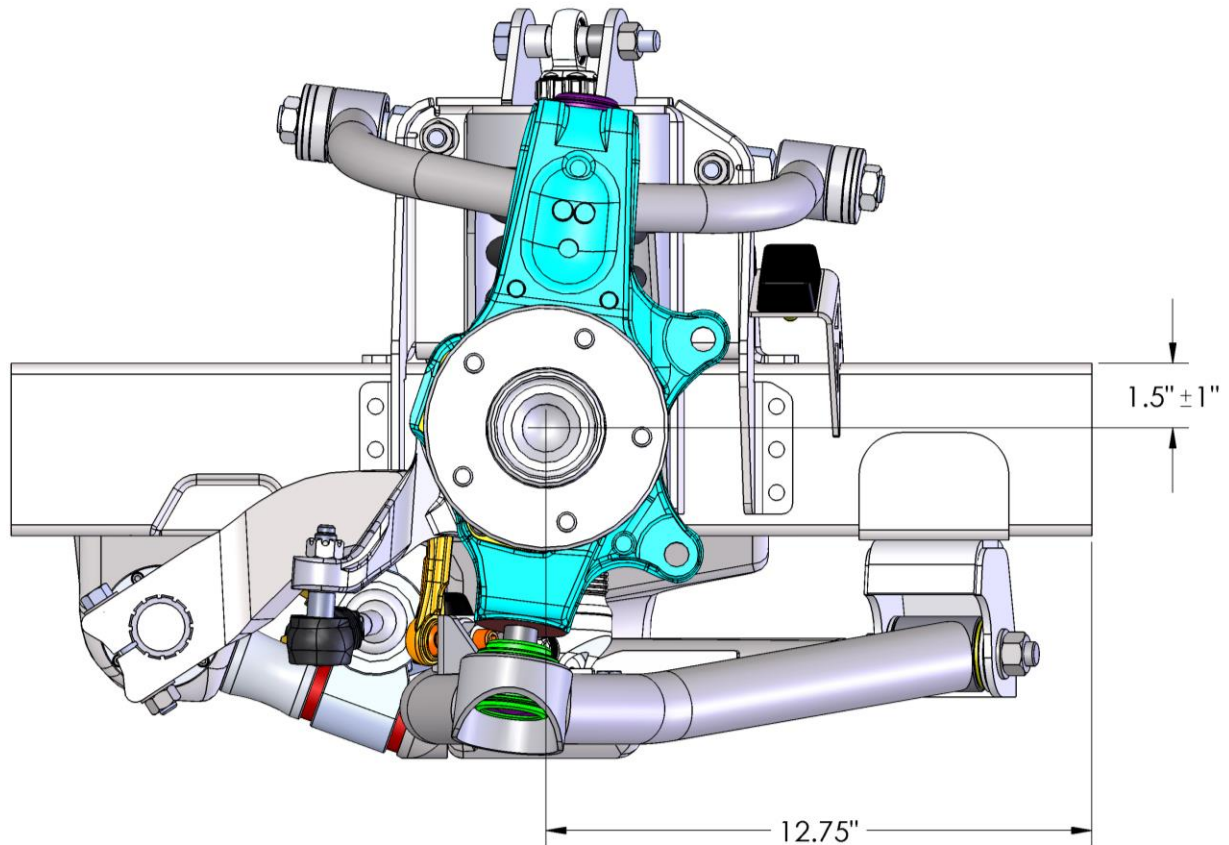

**Figure 1 - X-Gen Wheel Centerline Location**

- Once the X-Gen frame is located appropriately, build the factory frame rails into the X-Gen frame rail sections. Drill the frame rails so that the included 11-gauge frame rail doubler sleeves can be plug welded into the interior of the frame rails for added strength and security at the weld joints. Depending on your frame rail configuration, modifying the doubler sleeves may be necessary, but do not skip installation completely. The amount of doubler sleeve in either rail section should be as close to equal as possible (about 2"). Install the doubler sleeves on the factory rail first to make installation of the X-Gen frame section easier. When fitting the new rail sections, leave an appropriate weld gap at each weld joint. Tack the new frame rails together at this time.
- Once the rails are tacked securely in place, double-check all measurements and mockup all frame-mounted components of the front section of the car (including the new suspension) to ensure proper fitment before the frame is finish-welded.
- When you are satisfied with all component fitments, remove all front components again and finish-weld each frame rail weld joint. See Figure 2 on the next page for Detroit Speed's recommended weld locations.

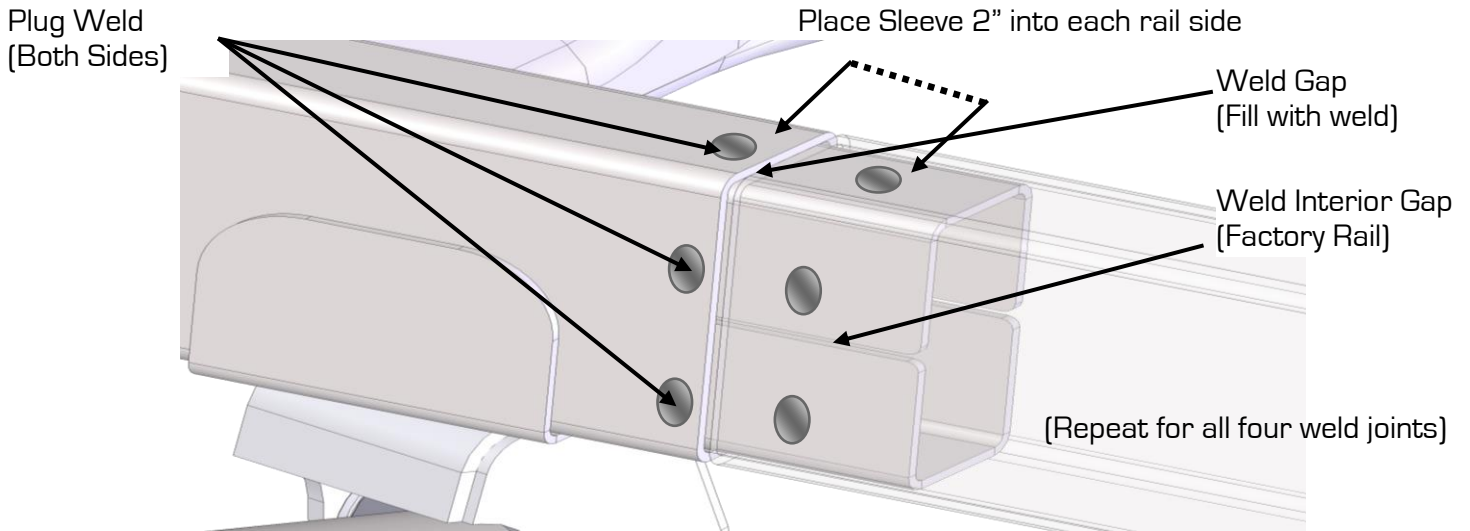

Figure 2 - Frame Rail Doubler Sleeve Final Installation

### Assembling the Frame

**NOTE:** Be sure the frame rails are free of any loose media or particles that may have collected in the rails. Do this with compressed air. Pay particular attention to the front crossmember. Any foreign particles left in the front crossmember could possibly damage the anti-roll bar end support bushings.

#### 1. Install lower control arm assemblies.

- a) Install the correct lower control arm (driver or passenger side). The jounce bumper is located on the forward tube of the control arm. See Figure 3.



Figure 3 - Lower Control Arm

- a) Be sure to use the correct bolts to mount the control arms. The short bolt (9/16-18 x 3-1/2" L) is used in the front bushing of the control arm and the long bolt (9/16-18 x 3-3/4" L) is used in the rear bushing of the control arm. Both bolts pointing forward will allow the control arms to be removed from a fully assembled frame. Use anti-seize on the threads of the bolts. Using the provided 9/16"-18 Nylock nuts and washers, torque the lower control arm bolts to 95 ft-lbs.

## 2. Install the rack and pinion assembly.

- a) Before the rack and pinion is installed, you can center the rack on the bench before it is installed. Mark a line along the length of the input shaft. Turn the rack all the way to one side and mark the housing where the line on the input shaft lines up. Turn the rack all the way in the other direction and count the turns in the opposite direction. Mark the housing where the line on the input shaft lines up. Turn the rack back in the opposite direction  $1/2$  the amount of turns so that the line on the input shaft lands in between your two marks on the housing (Figure 4).



Figure 4 – Center the Rack & Pinion

- a) When installing the rack and pinion, protect the opening in the crossmember to avoid chipping the paint as clearances are tight in several areas. Install the rack and pinion assembly **from below the crossmember** for better clearance and easier alignment. **NOTE:** Since the rack and pinion fits tight to the crossmember this would be a good time to install your fittings before it is fully installed. You can reference Figure 18 for the location of the pressure and return ports.
- b) Once the rack is in place, slide the aluminum spacers in place between the rack and the front crossmember and install the bolts. Use anti-seize on the bolts and torque to the specification in the chart.
- c) Rotate the rack to the rear of the front frame to install in the crossmember in the correct position (Figure 5).

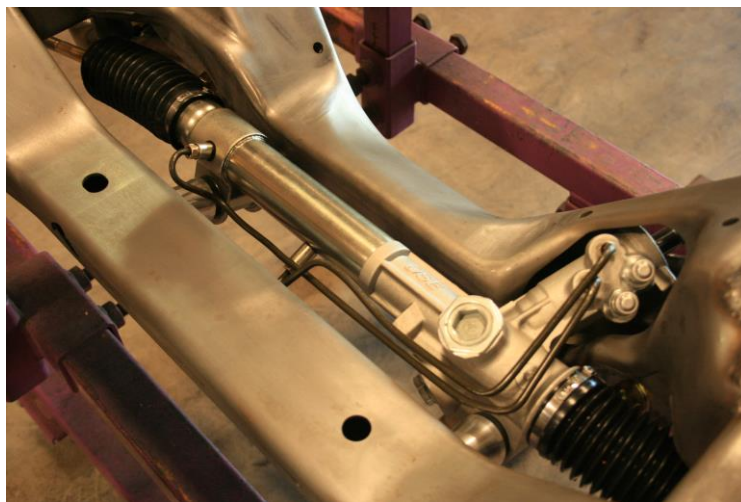

Figure 5 – Installed Rack

### 3. Install the sway bar.

- a) Lube the outside of the composite bushing with soapy water. Lube the inside of the bushing and do your best to fill the interior bushing grooves with chassis grease.
- b) Before sliding the anti-roll bar in place, clean the outside of the bar thoroughly with lacquer thinner to remove any foreign materials from the bar.
- c) Once the bar is clean, slide the bar in place. After the bar is in place, install the composite bushings. The bushings may not push in completely by hand (Figure 6). Do not be concerned, as they are designed to be a very precise fit. With the bar and both bushings installed, use a large diameter socket and rubber hammer to seat the bushings on both sides at this time (Figure 7).



Figure 6– Installing the Bushing & Anti-Roll Bar



Figure 7 – Fully Installing the Bushings

- d) After installing the bar and pushing the bushings in all the way, center the bar in the crossmember. Measure the portion protruding from the bushings on each side as in Figure 8 and adjust accordingly until this measurement is the same on both sides. Make sure to reseat the bushings against the frame before measuring, as they can shift when you move the bar and throw off your measurements.



Figure 8 – Measuring the Anti-Roll Bar

- e) Install the sway bar shaft clamps next. Loosen both Allen screws in the lock collar. Apply medium strength Blue Loctite 242 to the threads and position the clamp onto the sway bar. With the heads of the bolts accessible from the bottom, torque the bolts. **NOTE:** Be sure that the groove in the clamp is installed so that it points toward the center of the frame and the size marking is to the outside.

4. **Pre-assemble the sway bar end links to the sway bar arms.**
  - a) Fully thread the sway bar end link into the threaded hole on the end of the sway bar arm. **NOTE: It is critical to use High strength Red Loctite 262 on the threads and torque.** Figure 9 below shows the assembling of the sway bar arm.



Figure 9 – Pre-assemble the Sway Bar End Links

5. **Install the sway bar arms.**
  - a) Make sure both arms are positioned the same on the splines and are even in relation to one another. To determine, position the sway bar arm so that it is parallel with the bottom of the framerail.
  - b) When both arms are parallel with the bottom of the framerail, bolt them in place. The bolt will go through the arm and line up with the groove in the end of the sway bar tube.
  - c) Torque the sway bar arm to sway bar tube retaining bolt.
  - d) **DO NOT** attach the sway bar end links to the lower control arms at this point. This will be done at a later step.
6. **Install the jounce bumpers for the upper control arms.**
  - a) Position the jounce bumpers on the frame (Figure 10).



Figure 10 – Installed UCA jounce bumper

- b) Use the 3/8" – 16 Nylock nut and 3/8" flat washer and torque.

7. **Install each coilover assembly.**

a) Before installing each coilover, it is necessary to build each assembly.

- (1) Remove the upper spring seat from the retaining ring using a rubber hammer and moving it down off the upper shock mount as seen in Figure 11.
- (2) Remove the retaining ring from upper shock mount and pass the upper spring seat over the upper shock mount as seen in Figure 12.



Figure 11 – Removing the Upper Spring Seat



Figure 12 – Upper Spring Seat & Retaining Ring

- (3) Thread the spanner nut all the way to the bottom of the coilover shock and install the Torrington bearing set (Figure 13) on each shock by installing one thrust washer, followed by the roller bearing and then another thrust washer. DSE recommends using high pressure grease between the roller bearing and thrust washers.



Figure 13 – Torrington Bearing Set

- (4) Slide the coilover spring over the top of the upper shock mount.
- (5) Install the upper spring seat back over the top of the upper shock mount and re-install the retaining ring back onto the upper shock mount. Press the upper spring seat up onto the retaining ring so it locks in place.

The coilover assembly is now complete and ready to be installed

- b) Make sure the upper mounting hole is clean and free of any paint so the bolt and spacer slide into the mounting tab.
- c) Slide the 1/2" upper bolt with spacer through the eyelet and install the 1/2" Nylock nut and washer from the shock hardware bag provided. Use anti-seize on the threads of the bolts.

- d) Position the lower coilover mount to the lower control arm. Install the lower retaining bolts from the top side of the control arm. Torque all coilover hardware. Figure 14 shows a completed and installed coilover spring assembly.



Figure 14 – Installed Coilover View

8. **Attach the anti-roll bar arm end links to the lower control arm.**

- Insert the anti-roll bar end link into the mounting bracket on the lower control arm on either the driver or passenger side. Install the nut and loosely tighten.
- On the opposite side, push up on the lower control arm and insert the anti-roll bar end link in the bracket on the lower control arm. Use High Strength Red Loctite 262 on threads of the end links.
- With both sides installed, torque the nuts on the end links.

9. **Install the upper control arm assemblies.**

- Obtain the proper Driver or Passenger side Upper Control Arm. Refer to Figure 15 below to help determine.
- Apply High Strength Red Loctite 262 to the threads of the bolts before installing nuts. Be sure to install a flat washer on both the head and nut side of the bolt.
- Once the nuts have been installed, insert two shims on each bolt and torque the bolts. An installed view is shown below in Figure 16.

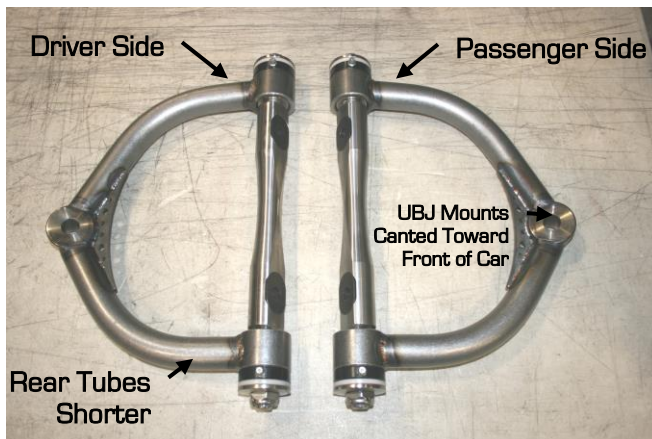

Figure 15 – Driver & Passenger Upper Control Arms



Figure 16 – Installed Upper Control Arm

10. Install the outer tie rod ends.

- a) Apply anti-seize to the tie rod end threads, then thread the outer tie rod ends onto the rack and pinion.
- b) When installing the tie rod ends, make sure they are equal distance on each side to center the steering. To verify, measure from the end of the threads to the edge of the jam nut. This measurement should be approximately 3/4" per side.
- c) Torque the tie rod end jam nuts to 45 ft-lbs. and thread the grease fittings into the tie rod ends.

11. Install the Detroit Speed spindle assembly.

- a) Clean any grease from the upper and lower ball joint studs and the spindle holes with a clean rag and lacquer thinner.
- b) Install the spindle to the upper control arm first.
- c) Tighten the upper ball joint flanged lock nut and torque to 40 ft-lbs.
- d) Place the spindle on the lower ball joint.
- e) Tighten the lower ball joint flanged lock nut and torque to 20 ft-lbs. plus 180° clockwise.  
**NOTE: It is critical to follow the torque procedure listed in the table on page 3 and to use High Strength Red Loctite 262 on the lower ball joint threads.**
- f) Insert outer tie rod end into the steer arm and torque. Install the cotter pin.

12. The suspension is assembled at this point. Figure 17 shows a completed installation. Double-check to ensure that all installed components are tight and torqued correctly.



Figure 17 - Fully Assembled View (Drive Side, Front)

13. After the frame is installed into the vehicle, the power steering hoses can be attached to the steering gear. Follow Figure 18 for the location of the pressure and return ports.

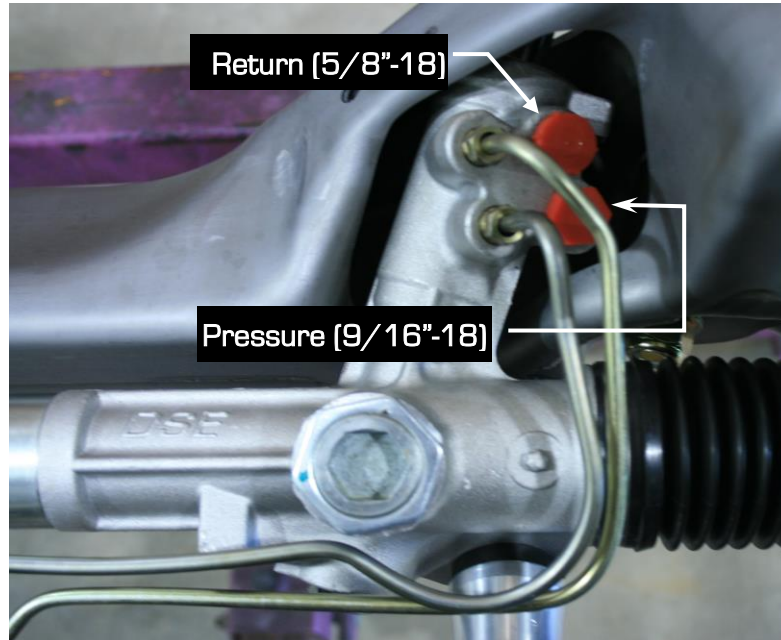

Figure 18 - Pressure and Return Port Locations

14. The front frame is now assembled and installed. **NOTE:** Be sure to lubricate all points on the front frame with quality chassis grease.

15. **Setting the vehicle ride height.**

- a) With the vehicle assembled with all components installed, adjust the vehicle ride height. Before adjusting the ride height, Detroit Speed recommends cleaning the threads of the shock. Once the threads are clean, apply dry bicycle chain lube to the threads of the shock body before adjusting the spanner nut and compressing the coilover spring. Allow the chain lube to dry before adjusting the spanner nut. If you have the non-adjustable shocks, the spanner nut has a soft tip set screw that will need to be tightened before the vehicle is driven.
- b) Detroit Speed does include a Spanner Tool (P/N: 031060DS) to adjust ride height however if you have the adjustable coilover shocks, Detroit Speed does offer an Adjustment Tool available as P/N: 031061DS if needed (Figure 19).



Figure 19 - Adjustable Spanner Wrench

16. If the Single Adjustable, Double Adjustable, or the Double Adjustable Remote Canister Coilovers were purchased as an upgrade, refer to the following information for adjustment procedures.

## Detroit Speed Single Adjustable Shock Applications

To change from the recommended “Detroit Tuned” valving, adjustments can be made independently to the rebound setting. The rebound is controlled by the knob at the upper shock mount (Shock is mounted body side down). The knob rotates clockwise (+) to increase the damping and counterclockwise (-) to decrease the damping. Refer to Figure 20a below.



Figure 20a- Detroit Speed Single Adjustable Shock

To return to the Detroit Speed recommended settings, turn the knob clockwise (+) to full damping. Once at full damping, turn counterclockwise (-) to reach the recommended settings. Refer to Figure 20b for the rebound settings.

Rebound (Shaft Knob) ..... 15 Open (counterclockwise, -)

Figure 20b - Detroit Speed Recommended Settings

### Adjuster Operation

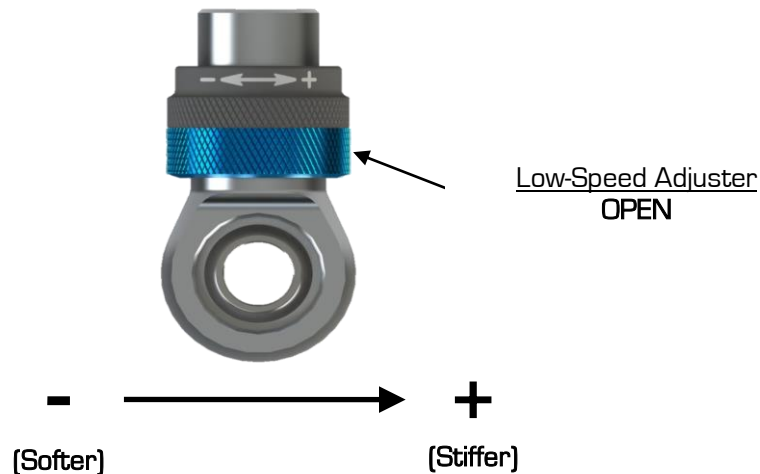

- **Adjuster (60-64 Clicks)**

The low-speed adjuster is a “clicker” style adjuster meaning that its adjustment is measured by detents located inside the blue adjuster knob. There are 16 clicks per 1 revolution of the knob. It uses a right-hand thread in its operation which means as you increase low-speed, the adjuster will move up on the eyelet. The recommended change for an adjustment is 8 clicks at a time. The low-speed adjuster’s reference position is **full stiff** (closed, or all the way up) and referred to -0 (-0 = full stiff, -64 = full soft).

- **Tuning Notes**
  - **Racetrack**
    - For more grip, soften the damping.
    - For increased platform control, stiffen the damping.
  - **Street**
    - For a more comfortable ride, soften the damping

**\*DO NOT FORCE KNOB WHEN IT STOPS TURNING, YOU MAY DAMAGE THE ADJUSTER AND INTERNAL HARDWARE**

***Detroit Speed Double Adjustable Shock Applications***

To change from the recommended “Detroit Tuned” valving, adjustments can be made independently to both the high and low speed settings. The rebound is controlled by the sweepers at the upper shock mount. The sweepers rotate clockwise (+) to increase the damping and counterclockwise (-) to decrease the damping. The sweepers can be seen in Figure 21a.



**Figure 21a – Detroit Speed Double Adjustable Shock**

When adjusting the low speed rebound start at full (+) position, when adjusting the high speed rebound start at full (-) position. To return to the Detroit Speed recommended settings turn the sweeper clockwise (+) to full damping for the low speed setting, and counterclockwise (-) to full damping for the high speed setting. Once at full damping, turn counterclockwise (-) for the low speed setting, and clockwise (+) for the high speed setting to reach the recommended settings. Refer to Figure 21b for recommended settings.

Low Speed Rebound (Sweeper)..... 15 sweeps (counterclockwise) (-)  
 High Speed Rebound (Sweeper)..... 4 sweeps (clockwise) (+)

**Figure 21b – Detroit Speed Recommended Settings**

***Detroit Speed Double Adjustable Shocks w/Remote Canisters***

To change from the recommended “Detroit Tuned” valving, adjustments can be made independently to both the high and low speed settings. The rebound is controlled by the sweepers at the upper shock mount. The sweepers rotate clockwise (+) to increase the damping and counterclockwise (-) to decrease the damping. Refer to Figure 22a on the next page.



Figure 22a – Detroit Speed Double Adjustable Shock w/Remote Canister

When adjusting the low speed rebound start at full (+) position, when adjusting the high speed rebound start at full (-) position. To return to the Detroit Speed recommended settings turn the sweeper clockwise (+) to full damping for the low speed setting, and counterclockwise (-) to full damping for the high speed setting. Once at full damping, turn counterclockwise (-) for the low speed setting, and clockwise (+) for the high speed setting to reach the recommended settings. Refer to Figure 22b for recommended settings.

Low Speed Rebound [Sweeper]..... 15 sweeps [counterclockwise] (-)  
 High Speed Rebound [Sweeper]..... 4 sweeps [clockwise] (+)

Figure 22b – Detroit Speed Recommended Settings

Adjuster Operation

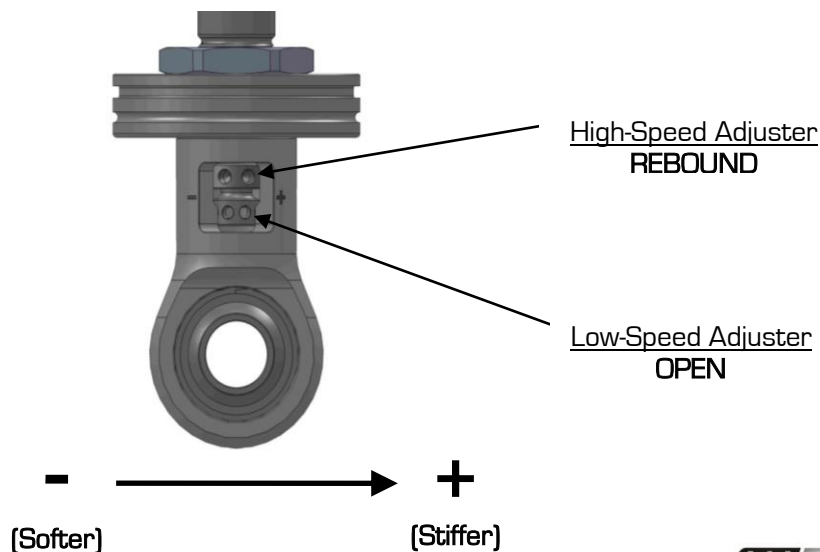

- **High-Speed Adjuster (12 Sweeps)**

The high-speed adjuster is a “sweep” style adjuster meaning that its adjustment is measured by the location of the adjuster in the eyelet window. It uses a left-hand thread in its operation which means; as you increase high-speed, the adjuster will move down in the window\*. The high-speed adjuster’s reference position is **full soft** and referred to as +0 (+0 = full soft, +12 = full stiff).

- **Low-Speed Adjuster (25 Clicks)**

The low-speed adjuster is a “clicker” style adjuster meaning that its adjustment is measured by detent grooves located inside the high-speed shaft. It uses a right-hand thread in its operation which means; as you increase low-speed, the adjuster will move up in the window. The low-speed adjuster’s reference position is **full stiff** and referred to -0 (-0 = full stiff, -25 = full soft).

*\*The low-speed adjustment does not change when adjusting the high-speed.*

To aid in the installation of the reservoirs, we also offer a set of Billet Aluminum Remote Canister Mounts. The canister mounts are available exclusively through DSE, P/N: 032102DS. They are shown in Figure 23.



Figure 23 – Billet Aluminum Remote Canister Mounts

17. Have a professional alignment completed following the specifications given in the chart on Page 2.

If you have any questions before or during the installation of this product, please contact Detroit Speed at [tech@detroitsspeed.com](mailto:tech@detroitsspeed.com) or 704.662.3272

**Legal Disclaimer:** Detroit Speed, Inc. is not liable for personal, property, legal, or financial damages from the use or misuse of any product we sell. The purchaser is solely responsible for the safety and performance of these products. No warranty is expressed or implied.