

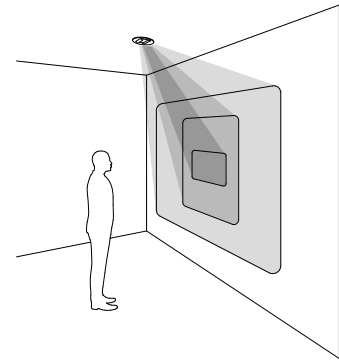

Tunable to Deliver Museum Quality Lighting for Art of Varied Sizes and Shapes



## PERFORMANCE

The Revelite CL-6 is a sleek design with robust performance. The CL-6 is adjustable in order to shape the illumination pattern for each unique piece of art, while delivering an even distribution of light for a range of shapes and sizes.

**A. Light Pattern Height Adjustment:** Two vertically aimable LED modules allow the height of the illuminated area to be adjusted.

**B. Light Pattern Width Adjustment:** Magnetically attached optical inserts horizontally spread the light, allowing the width of the illuminated area to be controlled. Five different inserts are included with the fixture.

**C. Uniformity:** The light intensity of each module can be adjusted to balance the brightness from top to bottom on the target area.

**D. Spill Light Control:** The baffle helps eliminate light that falls below the canvas.

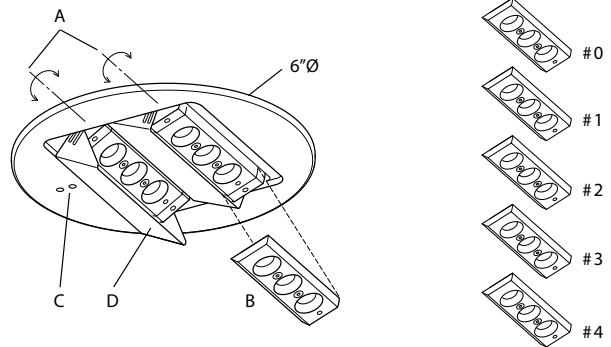

## SPECIFICATIONS

**Light Source Type:** Integrated LED  
**Color Temperature:** 2700K or 3000K  
**Color Accuracy (CRI):** 90+ (R9 vibrant reds: 80+)  
**Light Output (source):** 1140 lumens (3000K)  
**Dimensions:** 6" diameter, height varies (see drawings)  
**Weight:** 1.4 lbs  
**Dimming:** Forward & Reverse Phase, 0-10 V\*  
**Ratings:** UL Damp location, IC, Class 2  
**DC Load:** 15W @ 10 V DC

### Included Driver Specifications

**Input:** 110 - 277 V AC, 0.2 A, 50-60Hz  
 PF>9, THD<20%  
**Output:** 10 V DC Constant Voltage, 20W Max, Class 2  
**Remote enclosure included**

\* See Power and Control section for more information.



Patent Pending.

## SKU BUILDER

Revelite CL-6 part # CL-6- - -

### Mounting Method

Recessed Mount  
 Mud-In Recessed Mount  
 Surface Mount

R  
 M  
 S

### Metal Finish

Matte Black (CM-030)  
 Matte White (CM-126)

BL  
 WH

### Lamping

2700 K LED  
 3000 K LED

27  
 30

### Power Supply

120-277 V AC input voltage  
 TRIAC, ELV & 0-10 V dimmable

P1



## ARTWORK SIZES AND ILLUMINANCE LEVELS

Portrait and landscape rectangular illumination patterns can be achieved within the areas shown.

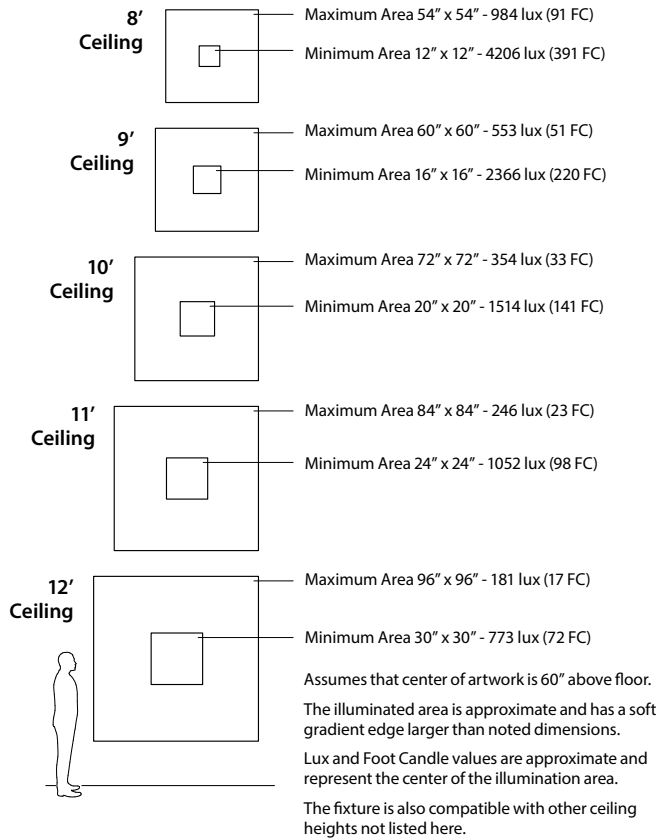

## MODULE LIGHT OUTPUT SPECS

| OPTICAL INSERT # | BEAM ANGLE FWHM* (H° X W°) | Max Luminous Intensity (cd) |
|------------------|----------------------------|-----------------------------|
| #0               | 15" X 15"                  | 4,700                       |
| #1               | 18" X 23"                  | 2,300                       |
| #2               | 18" X 37"                  | 1,700                       |
| #3               | 18" X 52"                  | 1,100                       |
| #4               | 20" X 70"                  | 675                         |

**Note:** Divide the max luminous intensity (candelas) by the distance (meters) squared to determine the illuminance (lux) at that distance from the light source.

\* FWHM refers to the Full Width Half Maximum method of beam angle measurement.

## PRODUCT TOUCHPOINTS

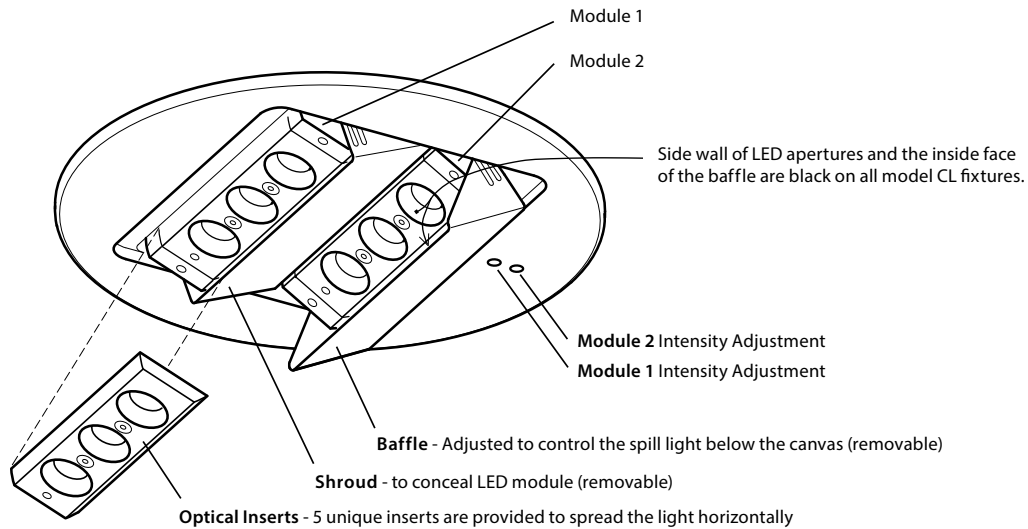

## MOUNTING LOCATION

The mounting location is dependent on the ceiling height and the mounting height of the artwork.

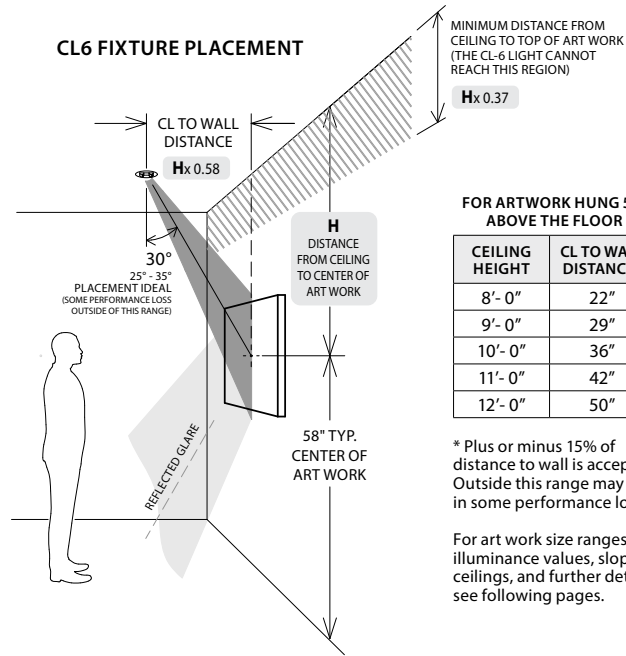

## MOUNTING METHOD

The fixture can be surface mounted, recess mounted, or flush recess mounted by using the mud in trim.

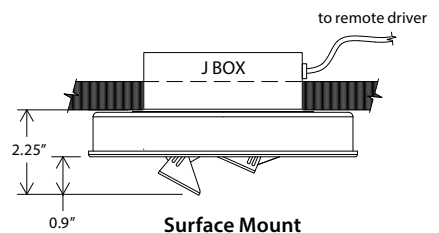
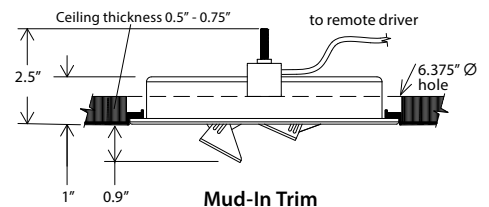
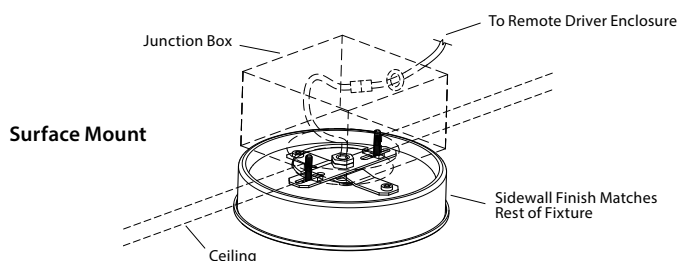
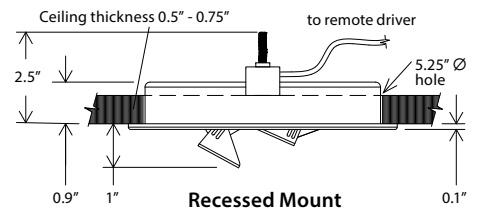
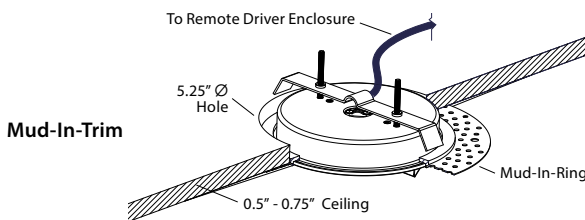
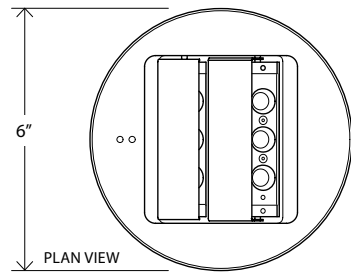
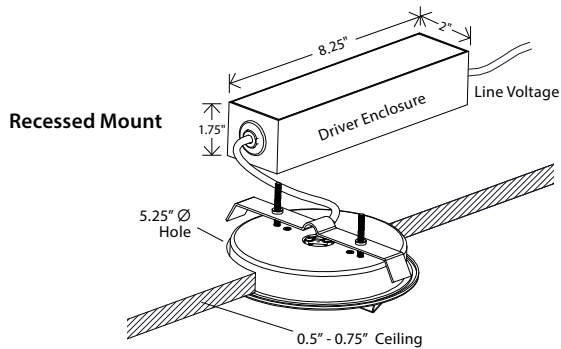

## SLOPED CEILINGS

Both modules can rotate from 0 degrees (beam center perpendicular to ceiling) to 50 degrees towards the target surface.

For the standard artwork height of 60 inches above the floor and fixture heights between 8 and 10 ft, roof pitches up to 20 degrees (about 4 in 12 roof pitch) are acceptable.

For art significantly higher or lower than 60 inches above the floor or for fixture height outside of the 8-10 ft range, special consideration must be taken to determine whether the artwork will fall within the rotation range of the Revelite CL-6.

Installation on ceilings that slope across the target surface is not recommended.

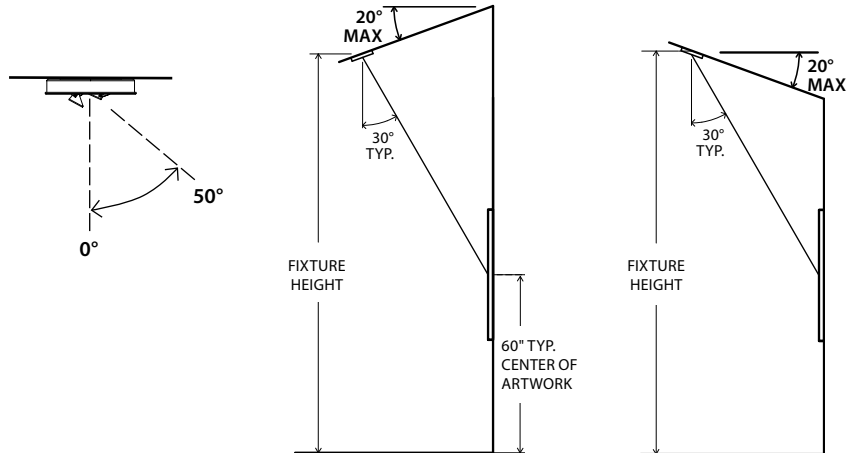

## POWER AND CONTROL

The Revelite CL-6 is a class 2 low voltage luminaire that must be connected to a remote 10 VDC power supply. The standard fixture comes with a power supply with an integral enclosure that can be installed in the ceiling near the fixture, or in a remote location. The fixture comes with 36 inch long, 18AWG wire leads. If the power supply is located farther away from the fixture, see below for the correct wire gauge to prevent excessive voltage drop.

Maximum wire length between power supply and fixture: **18 AWG - 10'** **14 AWG - 30'** **12 AWG - 50'**

**0-10V Dimming** - There are two ways to achieve 0-10V dimming. The preferred method is to connect the 0-10V dimming system directly to the Revelite CL-6 fixture. In this scenario, the remote power supply is not being dimmed and is supplying a constant 10VDC. This is the preferred method because it eliminates the chance of any compatibility issues between the dimming system and the power supply and will reliably allow dimming to about 5%.

The alternative method is to connect the 0-10V dimming system to the remote power supply. This method should only be considered if the power supply is being installed away from the fixture location and 0-10V dimming wiring is not available at each fixture location.

**0 - 10 Volt Dimming (Preferred)**

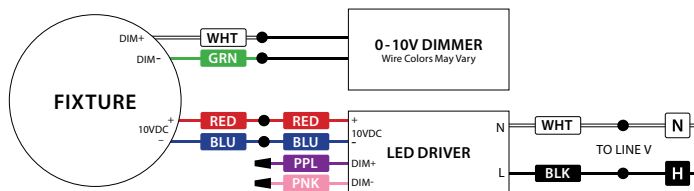

**0 - 10 Volt Dimming (Alternate)**

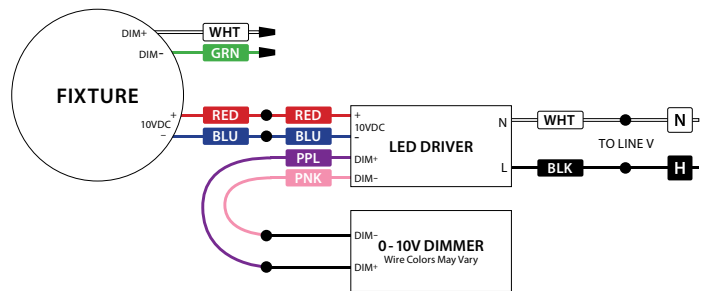

**Phase Dimming** - Forward and reverse phase dimming is achieved through the included remote power supply. Dimming to 5% is possible, performance will vary based on the dimmer used.

**Forward Phase Dimming**

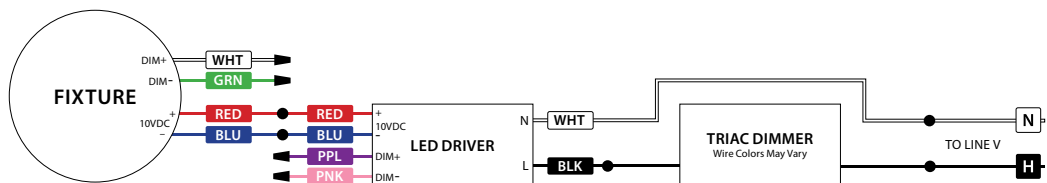

**Reverse Phase Dimming**

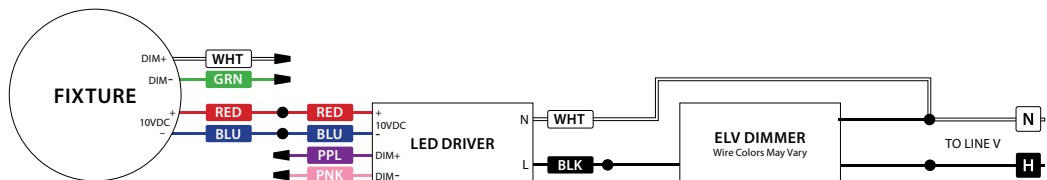

### APPLICATIONS FOR MULTIPLE CL-6 FIXTURES

For artwork that requires an illuminated area that is larger or brighter than can be achieved a single CL fixture, multiple CL fixtures can be installed. Spacing the CL fixtures closer together will increase the brightness of the illuminated area.

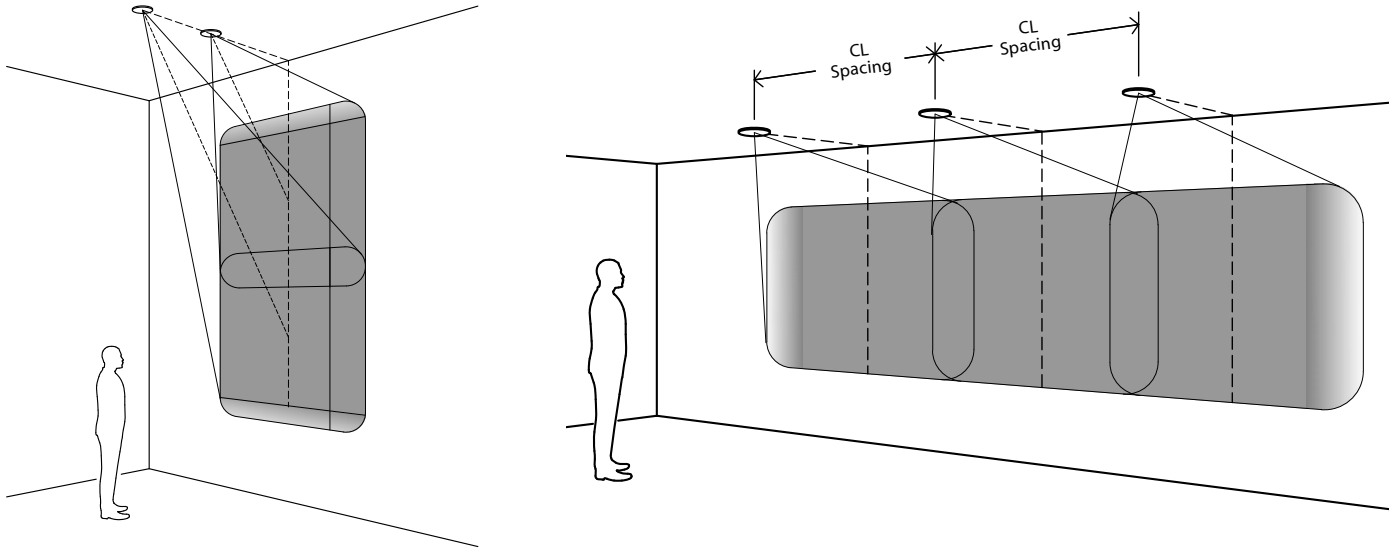

### GALLERY



Ceiling Height 9.5' | Art Work: 25" H x 17" W

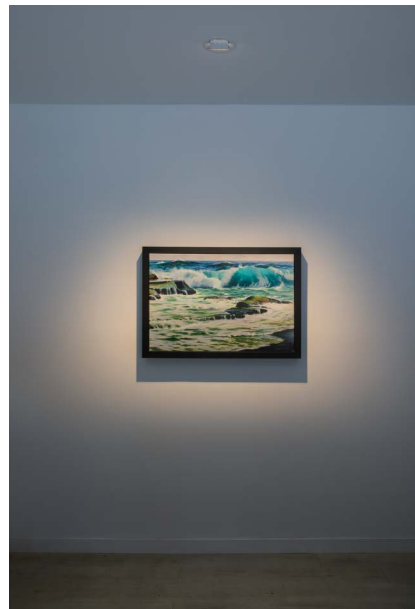

Ceiling Height 9.5' | Art Work: 27" H x 39" W

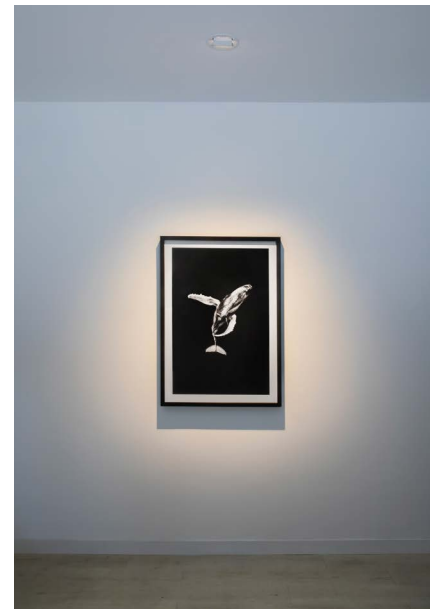

Ceiling Height 9.5' | Art Work: 42" H x 30" W



WATCH NOW!  
Revelite CL Ceiling Light - Adjustability  
and Performance Explained