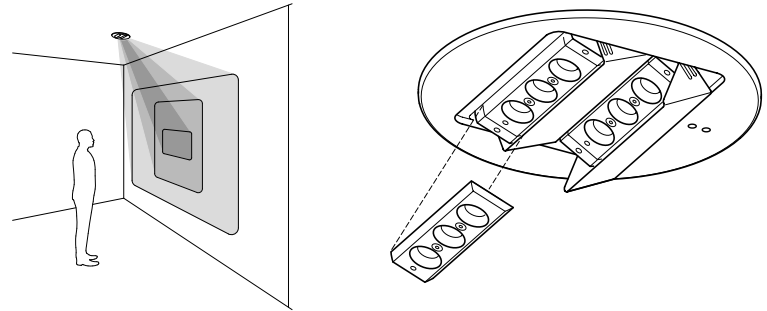

TABLE OF CONTENTS

Driver Information _____	1
Dimming and Wiring Information _____	2
Fixture Placement _____	3
Sloped Ceilings _____	3
Installation - Trimless _____	4
Installation - Recess _____	4
Installation - Surface _____	5
Adjustment - Types _____	6
Adjustment - Procedure _____	8



INTRODUCTION

Thank you for purchasing a Revelite CL-6. The Revelite CL-6 is a tunable ceiling mounted art lighting system that can be adjusted to shape the illumination pattern for each unique piece of art, while delivering an even distribution of light for a range of shapes and sizes. These instructions will cover how to install the fixture and adjust the light output to fit your art.

The Revelite CL-6 can be surface mounted, recess mounted, or flush recess mounted by using the mud in trim. Installation instructions for each of the mounting methods are covered here. Follow the applicable instructions based on the mounting style you have selected.



CAUTION - RISK OF FIRE



This product requires installation by a qualified electrician. Before installing be sure to read all instructions and **TURN POWER OFF TO THE INSTALLATION LOCATION.**

This is a low voltage fixture and must be used with an LED driver. **DO NOT** connect directly to line voltage

Damage due to incorrect connections can be detected at the factory and is not covered under warranty.

DRIVER INFORMATION

LED Driver - The Revelite CL-6 is a class 2 low voltage luminaire that must be connected to a remote 10V DC constant voltage LED driver. The standard fixture comes with an LED driver with an integral enclosure that can be installed in the ceiling near the fixture, or in a remote location.

The fixture comes with a 36 inch long 18/4 power cord. Two of the conductors are for 10V DC power and two are for 0-10V dimming. If the power supply is located farther away from the fixture, see below for the correct wire gauge to prevent excessive voltage drop. Make sure to make all electrical connections according to local building codes.

**Maximum wire length
between power supply
and fixture:**

18 AWG - 10'

14 AWG - 30'

12 AWG - 50'

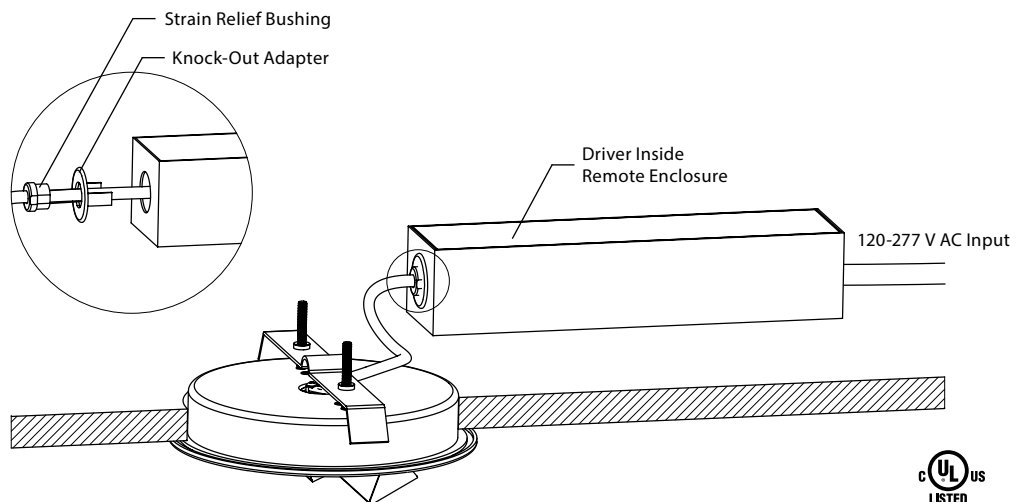

Patent Pending. Class 2 IC Rated

DIMMING AND WIRING INFORMATION

Dimming Considerations

The Revelite CL-6 has several dimming options. The recommended method is 0-10V dimming directly at the fixture. This will provide the most reliable and predictable performance. The fixture has a 36 inch long 18/4 power cord. Two of the conductors are for 0-10V dimming and can be connected to a dimmer or control system. Alternatively, if 0-10V dimming is not available at the fixture, the LED driver can be connected to a 0-10V dimmer, or it can be connected to a forward or reverse phase dimmer. Performance will vary and depends on the compatibility of the LED driver and the dimmer used.

0-10 Dimming Wiring Diagrams

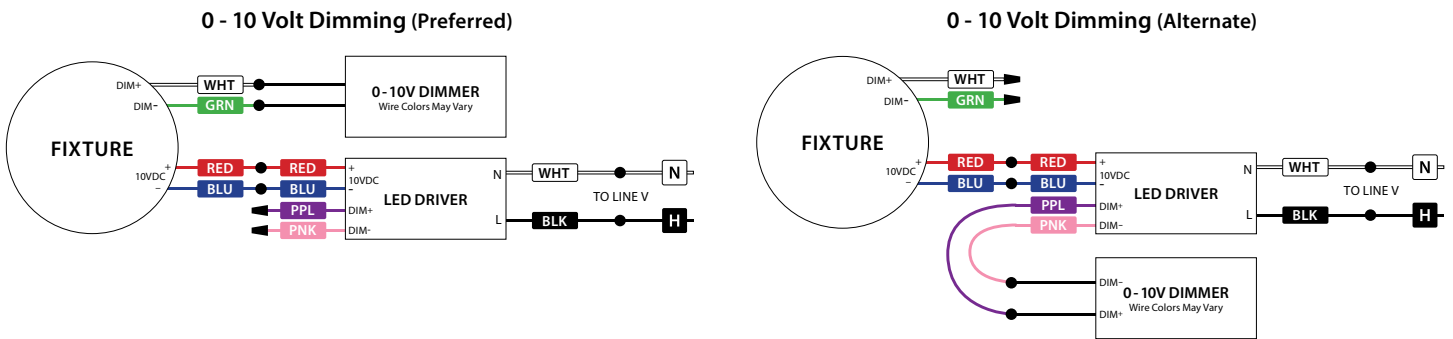

Phase Dimming Wiring Diagrams

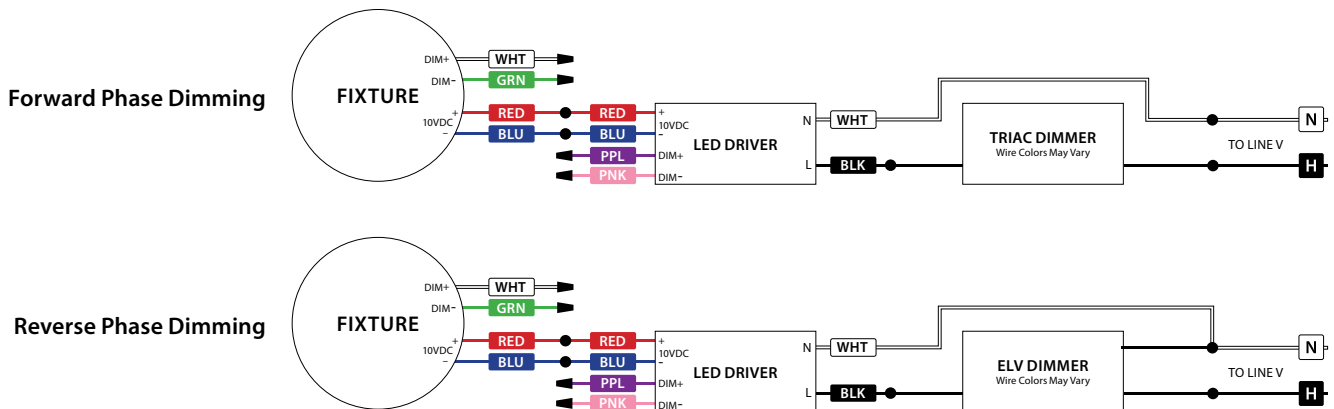

Patent Pending. Class 2 IC Rated

FIXTURE PLACEMENT

The fixture should be centered over the target area and should be spaced off of the wall as shown in the images below. If the center of the target area is about 60" above the floor (standard for artwork), use the table to determine the distance to the wall. Alternatively, if the center of the target area is significantly higher or lower, measure the distance from the ceiling to the center of the target area and multiply this number by 0.58 to determine the distance from the wall.

For Art 60" Above the Floor

CEILING HEIGHT	CL TO WALL DISTANCE*
8'- 0"	22"
9'- 0"	29"
10'- 0"	36"
11'- 0"	42"
12'- 0"	50"

* Plus or minus 15% of distance to wall is acceptable. Outside this range may result in some performance loss.

For Art Significantly Higher or Lower than 60" Above the Floor

Multiply the distance from the ceiling to the center of the artwork by 0.58 to find the optimal location to mount the CL-6 fixture from the wall.

⌚ Mounting location should be centered over the artwork.

SLOPED CEILINGS

Both Modules can rotate from 0 degrees (beam center perpendicular to the ceiling) to 50 degrees towards the target surface.

For the standard artwork height of 60 inches above the floor and fixture heights between 8 and 10 ft, roof pitches up to 20 degrees (about 4 in 12 roof pitch) are acceptable.

For art significantly higher or lower than 60 inches above the floor or for ceiling height outside of the 8-10 ft range, special consideration must be taken to determine whether the artwork will fall within the rotation range of the Revelite CL-6.

Installation on ceilings that slope across the target surface is not recommended.

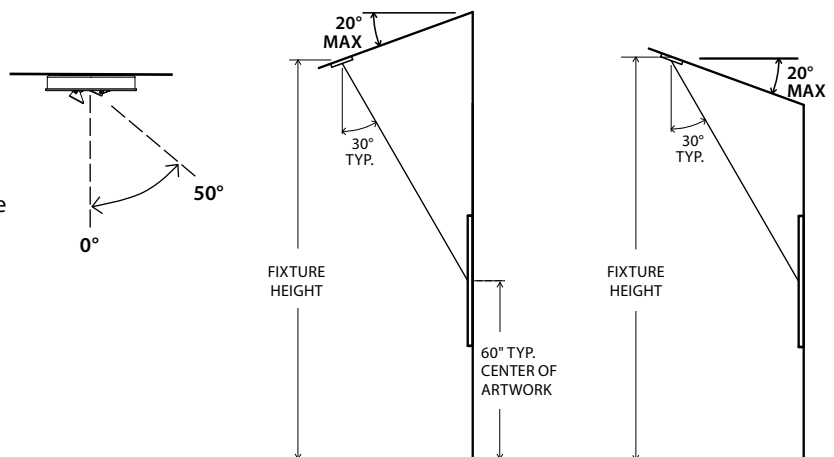

Patent Pending. Class 2 IC Rated

INSTALLATION - TRIMLESS

1. Cut a 6-3/8" diameter hole in the drywall ceiling.
2. Install the trimless mud ring into the hole and secure with drywall screws making sure that the screws are flush with the surface of the mud ring.
3. Apply plaster to the ring and the surrounding area to create a smooth transition. Allow plaster to dry, sand the area, and repeat as needed until desired result is achieved.
4. After the ceiling is painted, follow the recessed mount installation instructions to complete the installation.

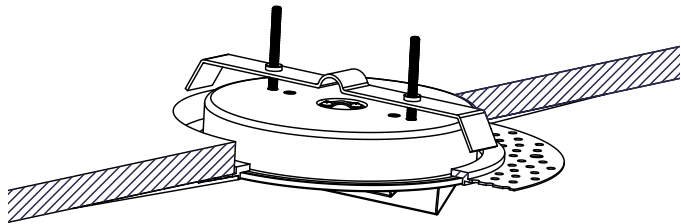
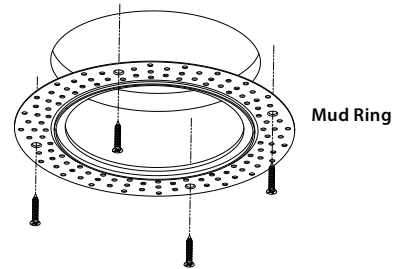

Power Cord and Driver Not Shown

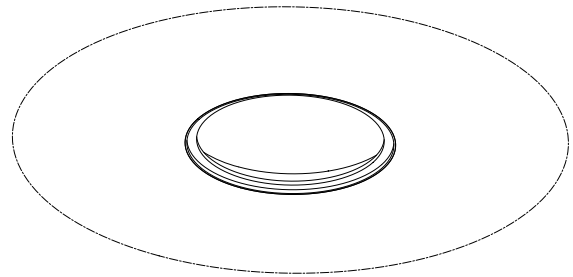

INSTALLATION - RECESSED

1. Drill a hole in the ceiling surface. The hole diameter should be 5.25" for the recessed mount.
2. Make electrical connections per the diagram on page 2.
3. Install the LED driver enclosure in the ceiling near the fixture, or in a remote accessible location. If installing remotely, make sure to choose the wire gauge according to the maximum wire length listed on page 1.
4. Attach the mounting strap to the fixture, leaving the strap fully extended above the fixture.
5. Insert the strap up into the ceiling so that it hooks onto the top surface of the ceiling. The strap is designed to work with ceiling thicknesses ranging from 1/2" to 3/4".
6. Tighten the mounting screws to draw the fixture up into the ceiling.
7. When tightening the mounting screws, rotate the fixture as needed until the LED modules are parallel to the target surface.
8. Adjust the fixture until the desired lighting effect is achieved (see Adjustment section).

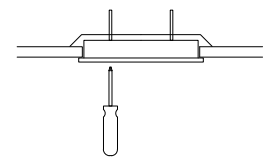
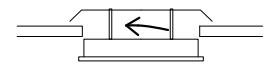
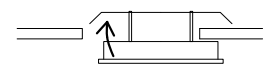
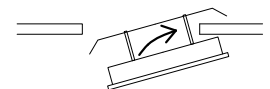

Installing in Ceiling

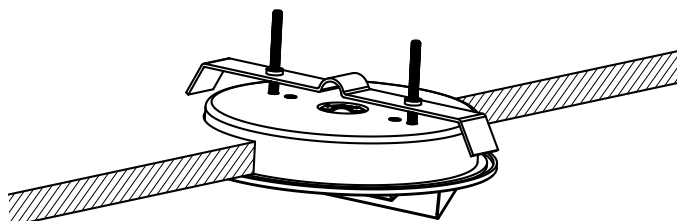

Power Cord and Driver Not Shown



Patent Pending. Class 2 IC Rated

INSTALLATION - SURFACE

1. Install a junction box in the desired location and run low voltage wiring from the remotely mounted LED driver to the junction box. Make sure to choose the wire gauge according to the table on page 1.
2. Install the crossbar assembly and attach ground wire. The lower crossbar should be oriented so the LED modules are parallel to the target surface when the fixture is attached to it.
3. Install the sidewall by running the cord through its center and seating it into the groove in the fixture.
4. Slip the cord through the center hole in the crossbar assembly and make electrical connections according to the wiring diagrams on page 2.
5. Thread the threaded studs a few turns into the holes in the lower crossbar. Use these threaded studs as guides to align the holes in the fixture with the crossbar.
6. One at a time, remove a threaded stud and install a flat head mounting screw in its place.
7. Before fully tightening the mounting screws, make any final rotation adjustments to align the LED modules with the target surface.
8. Adjust the fixture until the desired lighting effect is achieved (see Adjustment section).

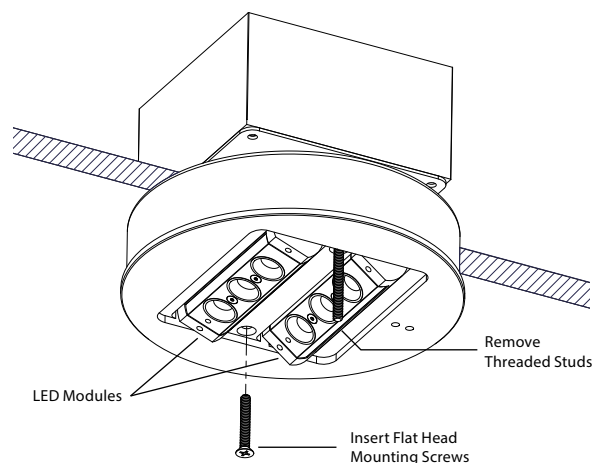
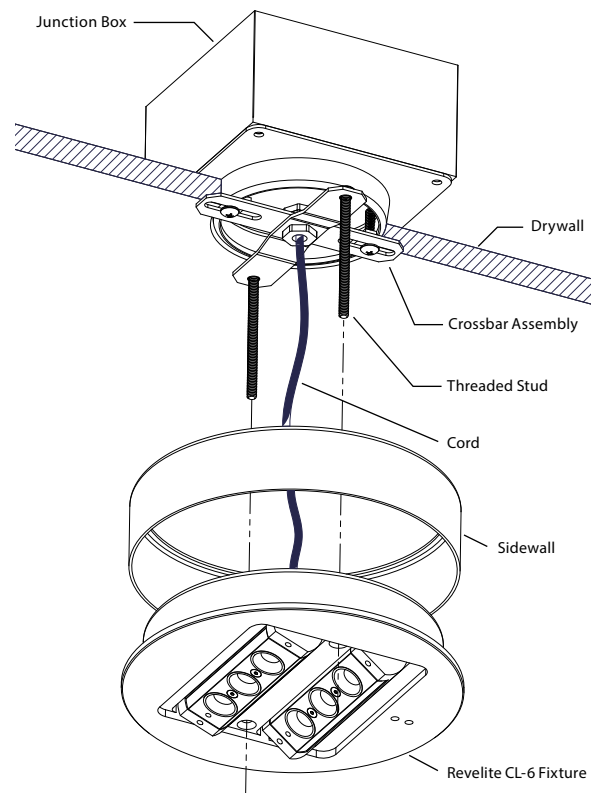
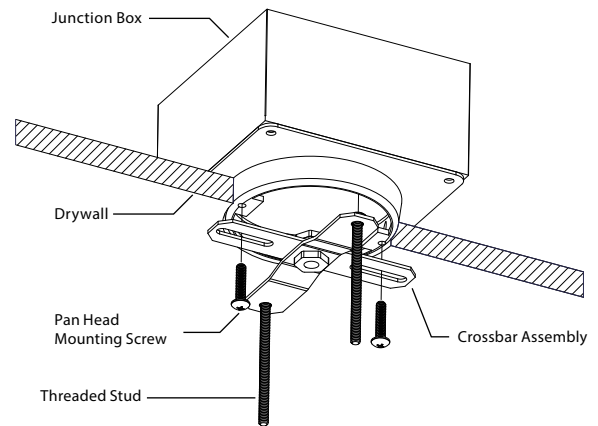

Patent Pending. Class 2 IC Rated

ADJUSTMENT - TYPES

The Revelite CL-6 is a highly adjustable fixture that has features that allow the shape and size of the illuminated area to be changed. This section illustrates the types of adjustments that the fixture is capable of. The next section will cover the recommended procedure for using these adjustments to optimize the light output for the target area.

LED Module Aiming - Each LED module can be rotated to vertically aim light in a certain area. Rotation is achieved by inserting the included module adjustment pin into one of the holes in the ends of the module and using it as a lever.

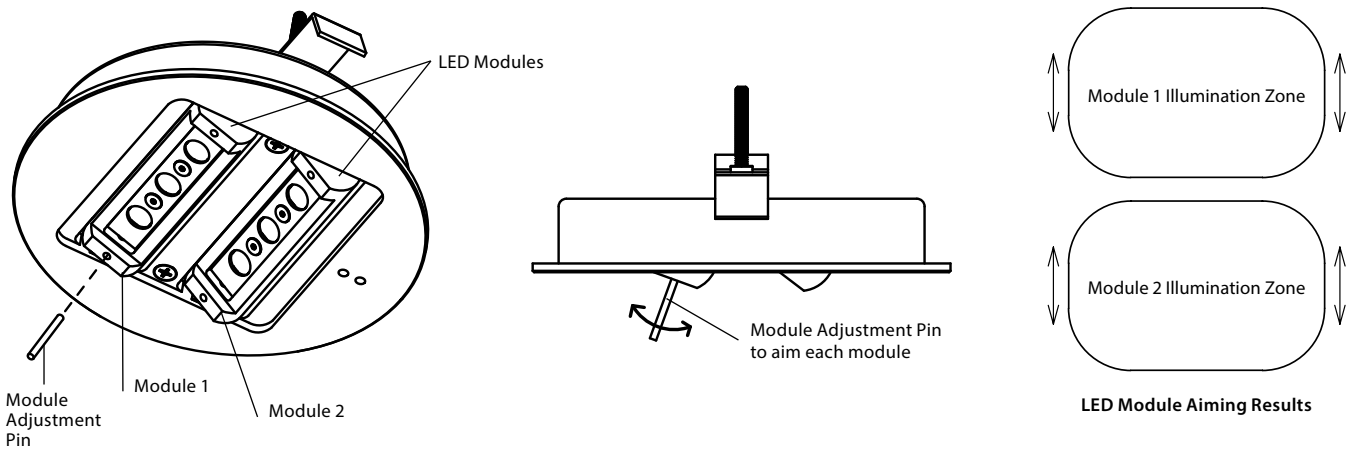

Illumination Width Control - Optical inserts are used to widen the beam of light produced by each LED module. They attach magnetically and are labeled with a number from #0 to #4. The larger the number, the wider the illuminated area. The supplied pin can be inserted into the hole in the optical insert and be used as a lever to gently lift it away from the LED module. Be careful not to touch the surfaces that light passes through because the oils on your fingers can affect performance.

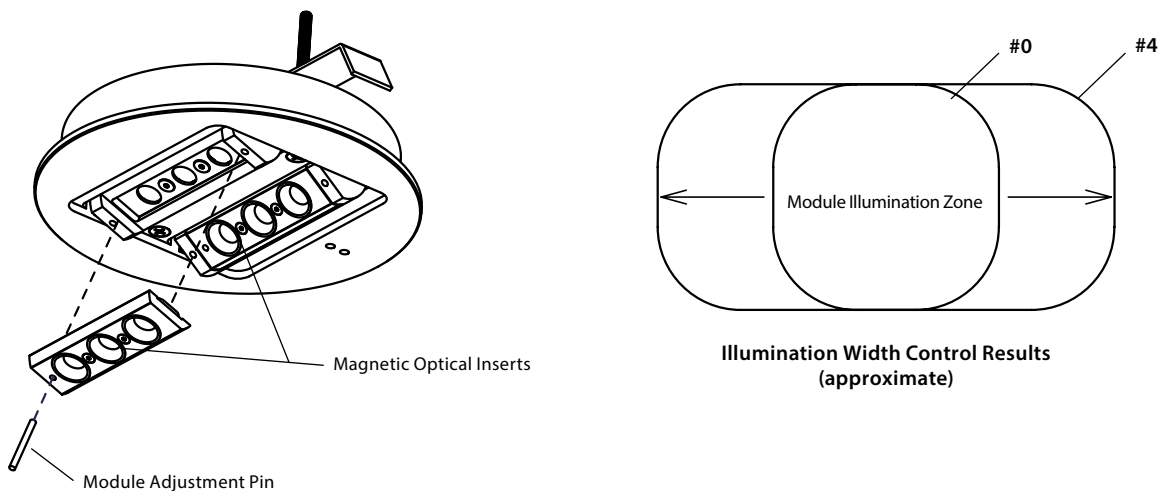

Patent Pending. Class 2 IC Rated

ADJUSTMENT - TYPES cont.

Intensity Adjustments - There are two small holes in the bottom face of the fixture that contain phillips head screws that control the intensity of each module. Turning the screws clockwise increases the brightness.

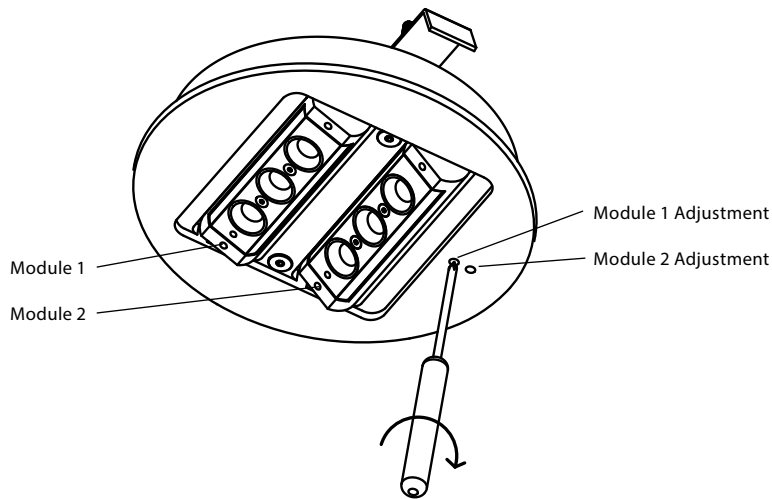

Baffle - The baffle is used to block and absorb some of the light emitted from LED module 2 that would spill onto the wall below the target area. The baffle is rotated into the path of the light beam to control the amount of spill light below the target area. It also helps to control direct glare. The inside surface of the baffle is lined with light absorbing black velvet.

Shroud - The shroud is a strictly cosmetic part that can be snapped into place over LED module 1 for an even cleaner look.

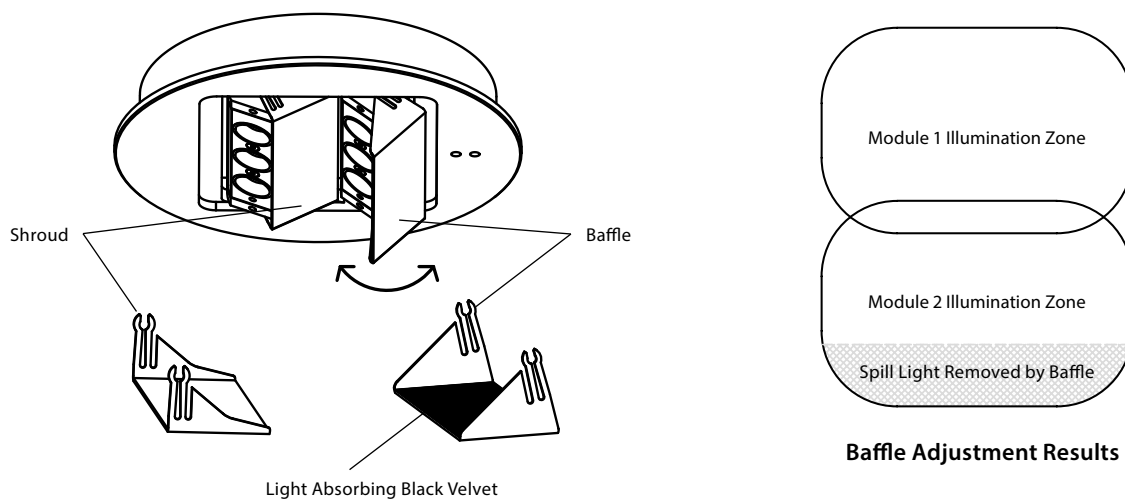

Patent Pending. Class 2 IC Rated

ADJUSTMENT - PROCEDURE

Below is the five step procedure recommended for optimizing the light output for a target area.

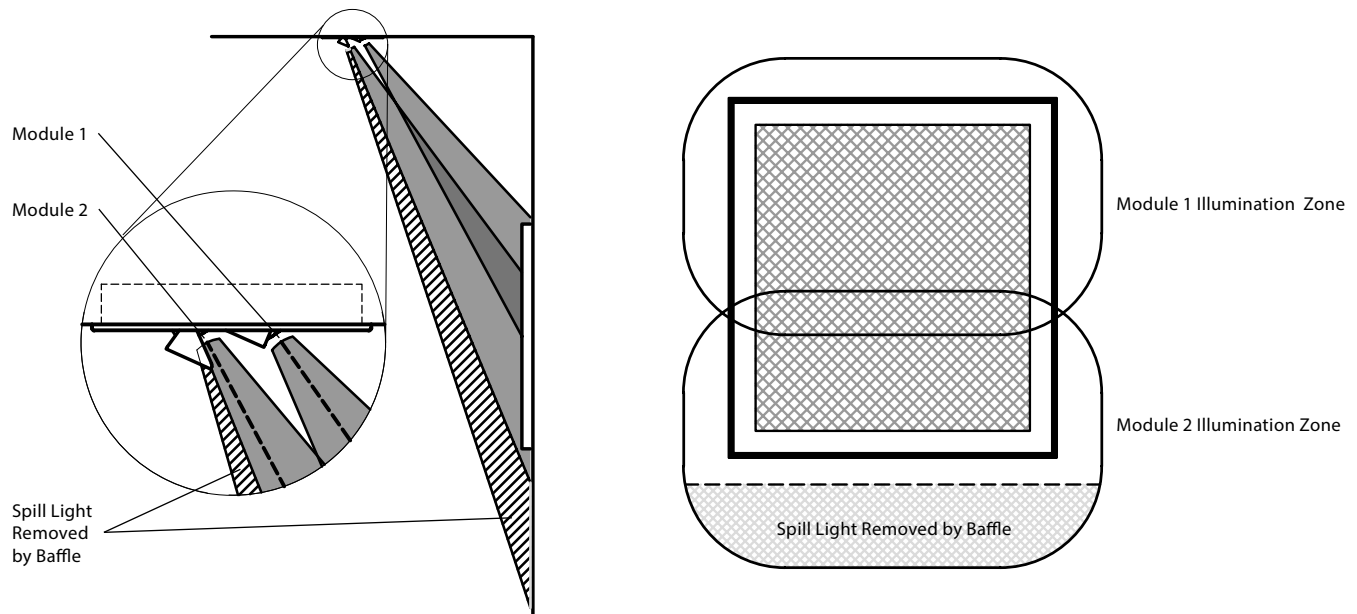

Optimized Light Shape After Adjustment Procedure

1. Optimize the bottom of the target area using module 2.

- a. Start by turning off module 1 (carefully turn the module 1 intensity adjustment screw all the way counter clockwise) and turn module 2 all the way on (turn the module 2 intensity adjustment screw all the way clockwise). This makes it easier to see the light pattern produced by module 2.
- b. Aim module 2 at the bottom portion of the target area.
- c. Test various optical inserts until the width of the illuminated area created by module 2 matches the target area. Larger numbered inserts will illuminate a wider area.

2. Optimize the top of the target area using module 1.

- a. Place an optical insert on module 1 that is one number higher than the one that you chose for module 2.
- b. Turn on module 1 by rotating the module 1 intensity adjustment screw clockwise.
- c. Aim module 1 so it fills in the top of the target area. If the width of the area illuminated by module 1 is too narrow, try a higher numbered optical insert.
- d. Adjust the intensity of module 1 so the light level at the top of the target area is similar to the intensity at the bottom of the target area.

Continue on next page....



Patent Pending. Class 2 IC Rated

ADJUSTMENT - PROCEDURE cont.

3. Control spill light below the target area using the baffle.

- a. The baffle has black velvet on its inner surface and is slightly larger than the shroud. Orient it as shown in the image below and snap it onto the pins protruding from the ends of the LED modules. There are clips built into the baffle that will flex as they snap around the pins.
- b. Once the baffle is in place, it can rotate around the LED module. As the baffle rotates into the beam of light coming from module 2, it will block some of this light and reduce light spilled below the target area. If rotated too far into the beam, the baffle will start to dim the entire area illuminated by module 2. If this happens, try aiming the module higher up on the target area.

4. Repeat steps 1-3 if further adjustments are needed.

5. Install the shroud

- a. The shroud installs in a similar way as the baffle. Make sure it is oriented and seated as shown.
- b. The shroud does not affect the light output of the fixture and is only a cosmetic cover used to improve the appearance of the fixture.

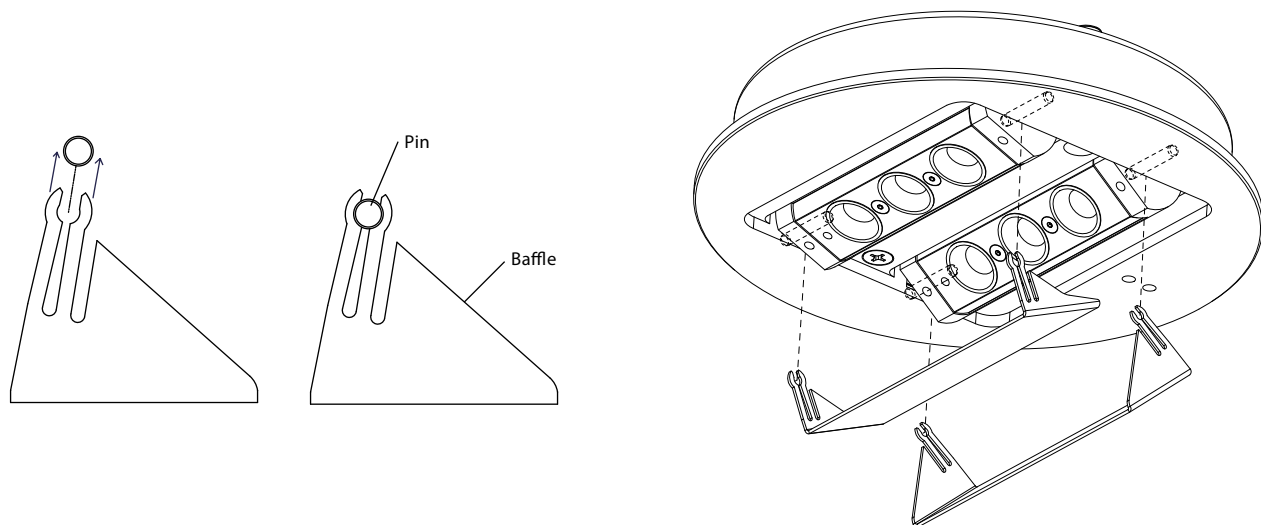

Installing Baffle and Shroud Clips to Fixture Pins



WATCH NOW!
Revelite CL Ceiling Light - Adjustability
and Performance Explained



Patent Pending. Class 2 IC Rated