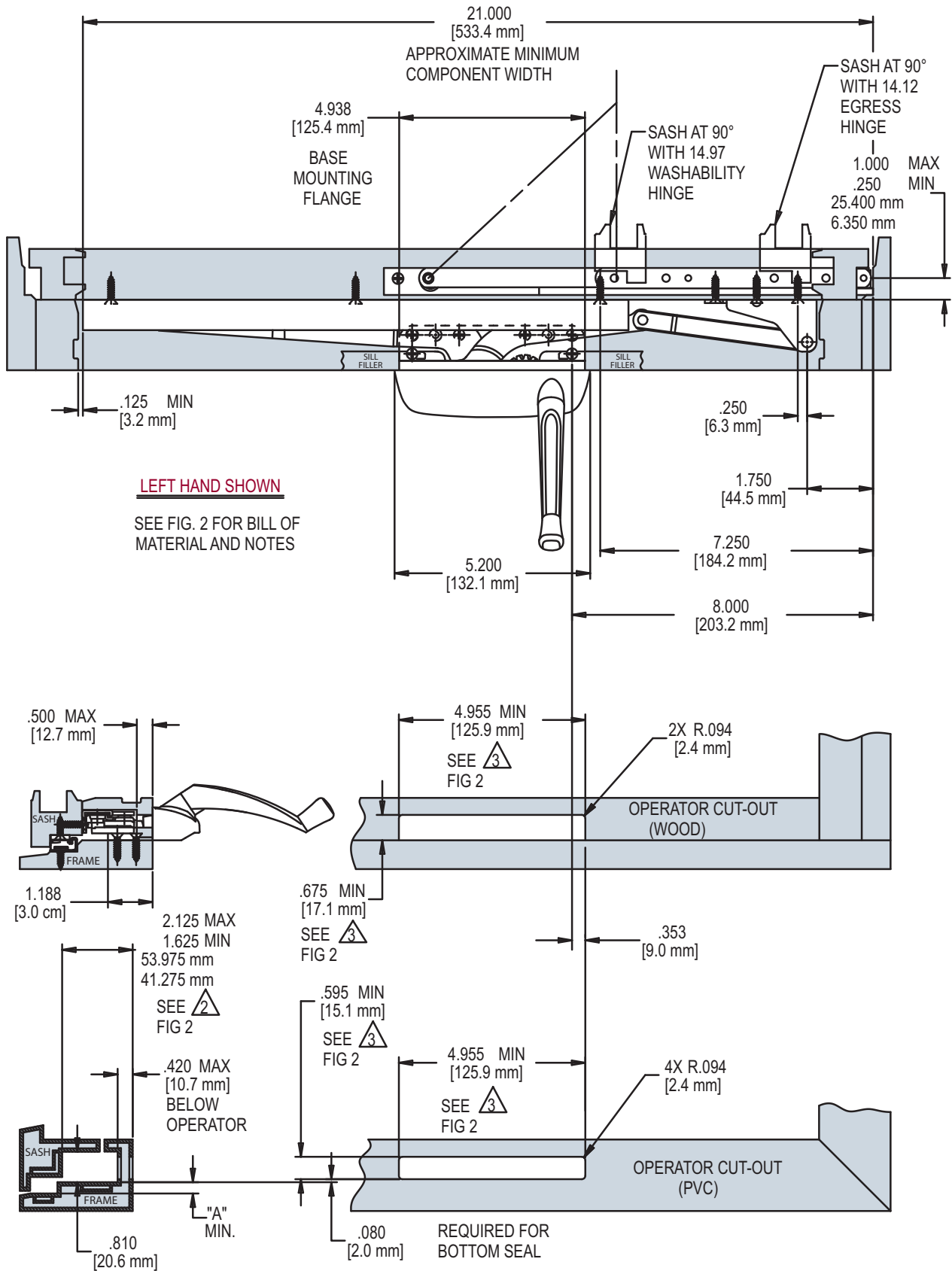
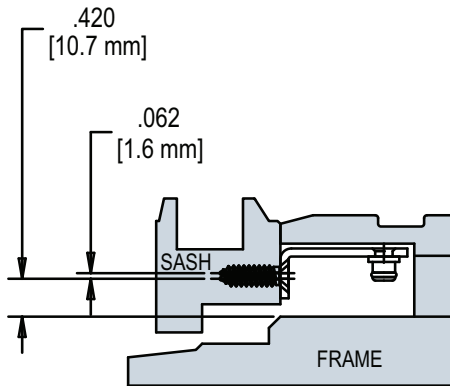

FIG. 1 APPLICATION OF MAXIM DUAL ARM OPERATOR (SILL MOUNT VERSION)



MAXIM® DUAL ARM OPERATORS (SILL MOUNT)

FIG. 2 APPLICATION OF MAXIM DUAL ARM OPERATOR (CONTINUED)
(SILL MOUNT VERSION)



12511.XX
BRACKET PLACEMENT

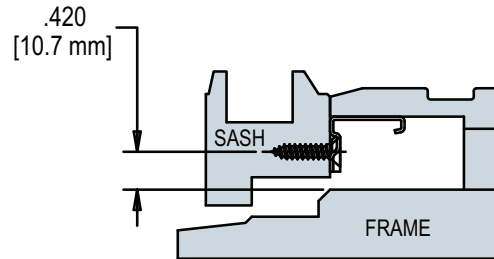

11576.XX
TRACK PLACEMENT

HARDWARE SHOWN FOR LEFT HAND WINDOW, SEE FIG.1	
PART NUMBER	DESCRIPTION
50.00.XX.011	DUAL ARM OPERATOR
12511.XX	STUD BRACKET
11576.XX	TRACK ASSEMBLY
14.97.00.XXX	WASHABILITY HINGE
11454.XX	CONTOUR HANDLE
31882	GASKET (PVC)

HINGE	"A"
14.97.00.XXX	.300 [7.6 mm]
14.12.00.XXX	
OTHER 14 SERIES CASEMENT HINGES	.250 [6.4 mm]

NOTES:

1. STUD BRACKET 12510.XX AND 12511.XX REQUIRES THE SAME MOUNTING LOCATION FOR BOTH THE ENCORE DUAL ARM OPERATOR AND THE ENCORE DYAD OPERATOR.

2. STUD BRACKET 12510.XX AND 12511.XX MAY NOT FIT IF 2.125/1.625 DIMENSION IS LESS THAN 1.875. CONTACT TRUTH FOR RECOMMENDATIONS.

3. HOLD THIS DIMENSION AS CLOSE TO THE MINIMUM AS MANUFACTURING TOLERANCES ALLOW. A CLOSE FITTING CUT-OUT HELPS TO STABILIZE THE OPERATOR AGAINST ROCKING

4. GASKET 32658 IS REQUIRED ON PVC AND METAL PROFILES FOR AN IMPROVED AIR AND WATER SEAL

FIG. 3 STANDARD MAXIM DUAL ARM OPERATOR (SILL MOUNT VERSION)

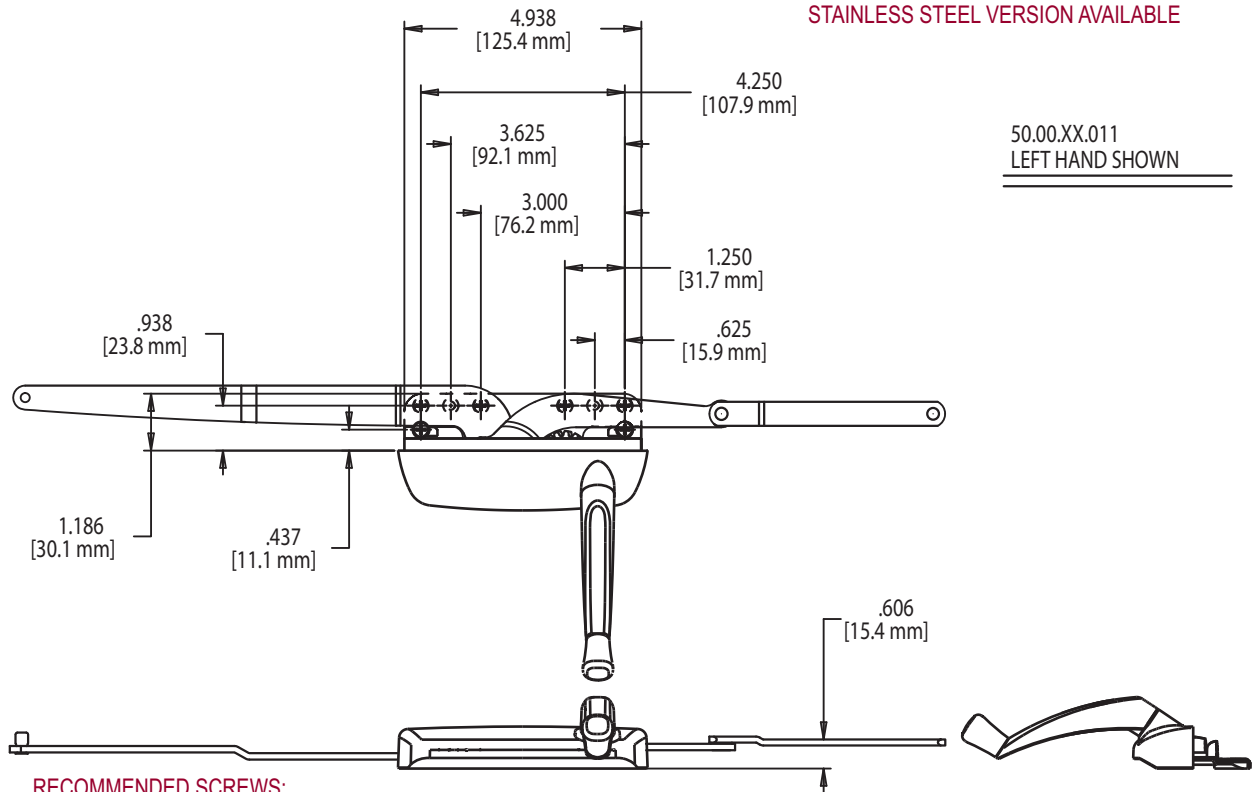

RECOMMENDED SCREWS:

(QTY 6)(PN 19240.XX)#8 X 1 FLAT HEAD SHEET METAL SCREW (SEE TRUTH TIPS FOR MORE INFORMATION)

(QTY 2)FOR REAR MOUNT:#8-32 X 3/8 PAN HEAD MACHINE SCREW PN 19545.XX

FIG. 4 MAXIM COVER 41211.XX /HANDLE 11329.XX(LH) (SHOWN)

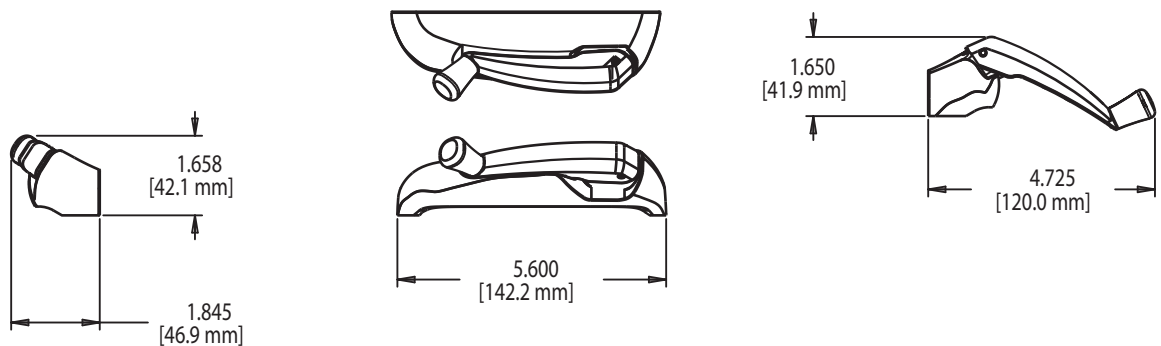

MAXIM® DUAL ARM OPERATORS (SILL MOUNT)

FIG. 5 BACK PLATE 23058.92

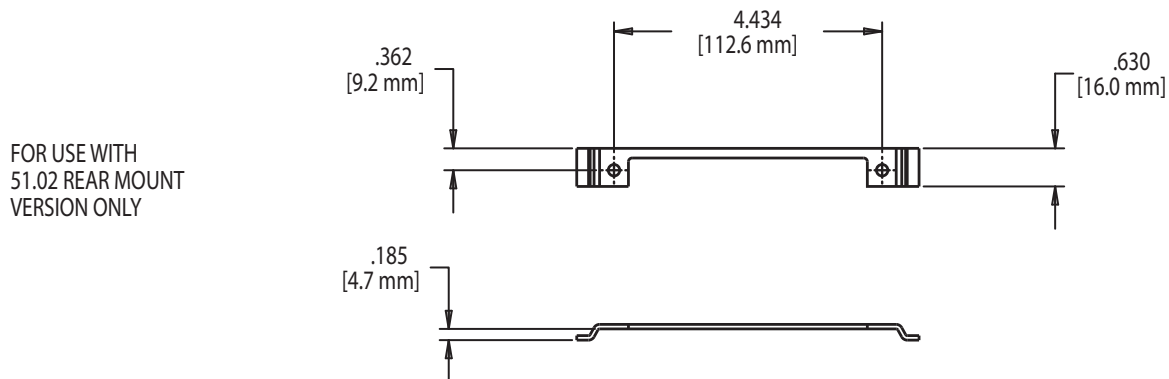

FIG. 6 TRACK & SLIDER ASSEMBLY 11576.XX

STAINLESS STEEL VERSION AVAILABLE

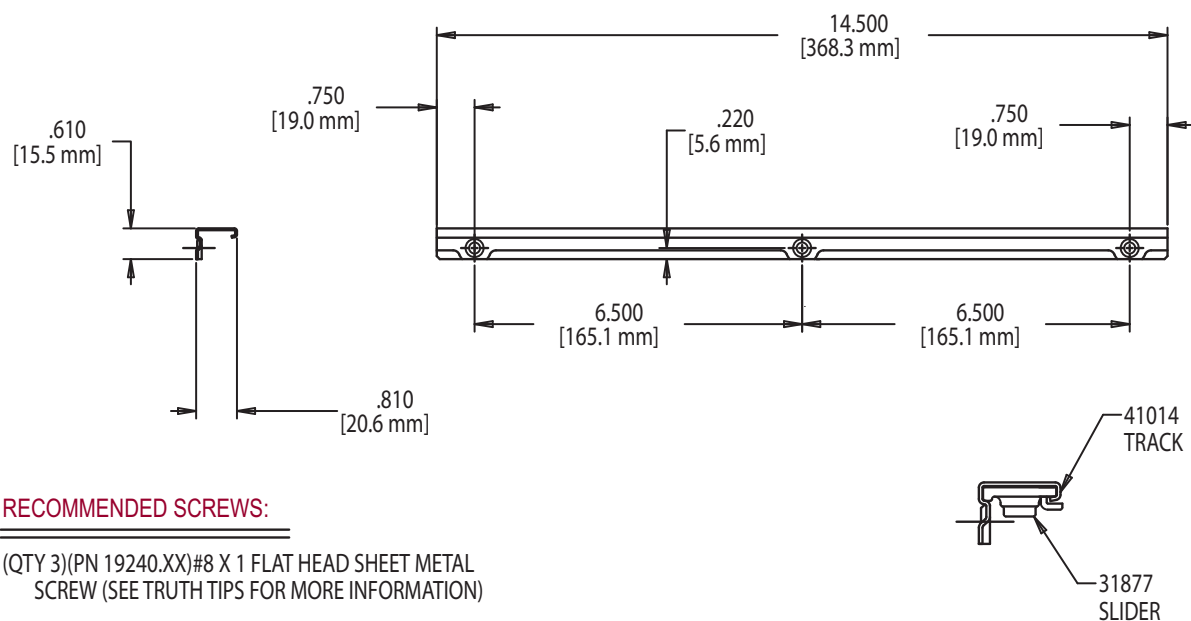
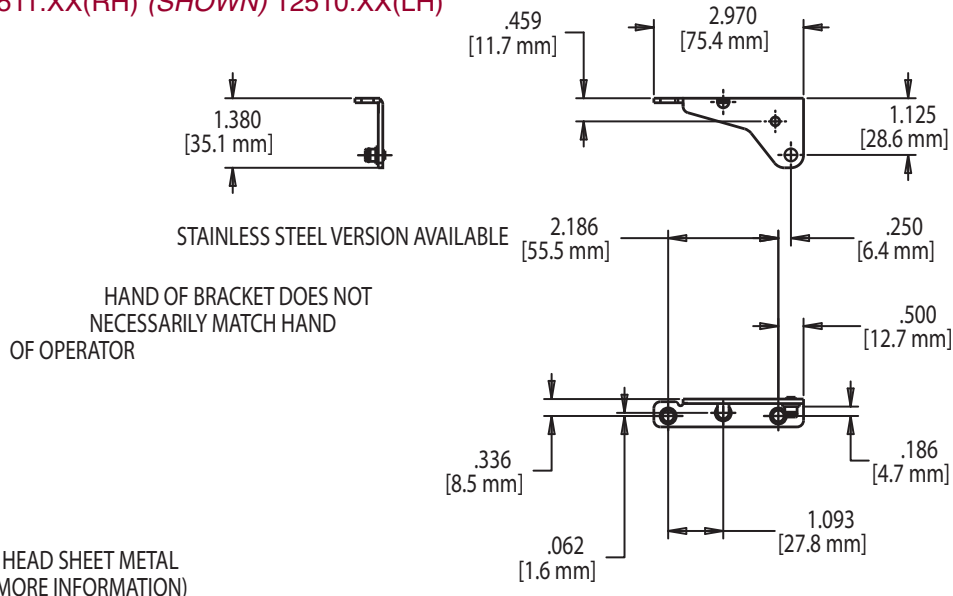

FIG. 7 STUD BRACKET 12511.XX(RH) (SHOWN) 12510.XX(LH)



RECOMMENDED SCREWS:

(QTY 3)(PN 19240.XX)#8 X 1 FLAT HEAD SHEET METAL SCREW (SEE TRUTH TIPS FOR MORE INFORMATION)