

# WOOD'S POWR-GRIP® PANEL MASTER VACUUM LIFTERS

Employing state-of-the-art technology, *Intelli-Grip*® automatically monitors vacuum and power systems to:

- Maximize productivity
- Help reduce human error
- Simplify maintenance and repairs
- Protect employees and property from harm



**MRTALP4625DC3**  
**MRTALP410TDC3**

**600 lbs [270 kg]**  
up to 1100 lbs [500 kg]  
with available options

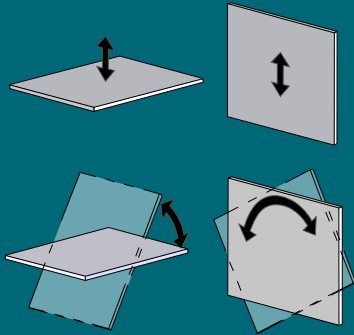

**THE ORIGINAL  
& TRUSTED NAME  
IN VACUUM LIFTING  
EQUIPMENT**

**800.548.7341**  
**WPG.com**

908 West Main - P.O. Box 368  
Laurel, Montana 59044 U.S.A.  
406.628.8231 (phone)  
406.628.8354 (fax)

Wood's Powr-Grip products are sold through authorized dealers.

Rev. 0.7 / 07-18 Spec. Sheet **8-11**

	MRTALP4625DC3	MRTALP410TDC3
<b>Maximum Load Capacity</b>	<b>600 lbs [270 kg]</b> for load thickness up to 12" [30 cm] 1100 lbs [500 kg] for flat lift with 8-pad options (see pages 2 and 3)	
<b>Intelli-Grip® Technology</b>	Automatic self-testing ensures lifter is ready for use, every lift. Color display provides critically relevant information at a glance. Anticipates threats and alerts operator beforehand with clearly visible and audible warnings. Continuously monitors battery and prevents lifter from attaching to loads if energy is hazardously low. Multiple alarm levels plainly identify the severity of hazards.	
<b>Dual Vacuum System</b>	Features two completely independent vacuum circuits. Provides vacuum system redundancy. Limits possibility of a catastrophic failure. Reduces chance of harm to personnel or equipment.	
<b>Standard Operating Power</b>	12 volts DC, 5 amps	
<b>Profile Thickness</b>	9¾" [250 mm] (does not include load)	
<b>Load Movement</b>	Manual rotation, 180° edgewise, with locking every 30° Assisted manual tilt, 90° between upright and flat, with automatic latching in upright position	
<b>Standard Features</b>	Intelli-Grip® technology Dual vacuum system Adjustable-position lift spool Low vacuum strobe light Low vacuum/power loss warning buzzer with back-up battery Green lift light High-capacity battery and charger Battery energy gauge Vacuum gauges Vacuum line filters Vacuum reserve tanks Blow-off for quick release Pad frame T-arm assemblies Movable pad mounts Spring-mounted vacuum pads	
<b>Available Options</b>	Pad frame extension arms for roof panels (97464) Pad frame rocker arms for roof panels (97463) Remote control system (59906) Available for lease	
<b>Design Standards</b>	ASME B30.20-2006 (BTH-1 Design Category "B", Service Class "0") CE	

(See [www.WPG.com](http://www.WPG.com) for more information.)

Based on product information at time of publication. Environmental conditions can affect product performance and longevity; consult the product instructions on [WPG.com](http://WPG.com) or contact a Technical Sales Representative for more information.

## MRTALP4625DC3

<b>Available Options</b>	Pad frame T-arm assemblies (97465) Pad extension arms (MRTALP811LDC3 or MRTALP810TDC3)
<b>Standard Pad Spread</b>	Maximum: 37" x 92-1/2" [94 cm x 235 cm] Minimum: 20" x 92-1/2" [51 cm x 235 cm]
<b>Lifter Weight</b>	250 lbs [114 kg]
<b>Number / Size of Pads</b>	4 / 6-1/2" x 25-1/2" [17 cm x 65 cm] foam rubber vacuum pads

## OPTIONAL PAD FRAME CONFIGURATIONS & CAPACITIES WITH VPFS625 PADS

Accommodates panels over 35 ft [10.5 m] in the standard configuration (maximum size shown - narrower configurations possible)

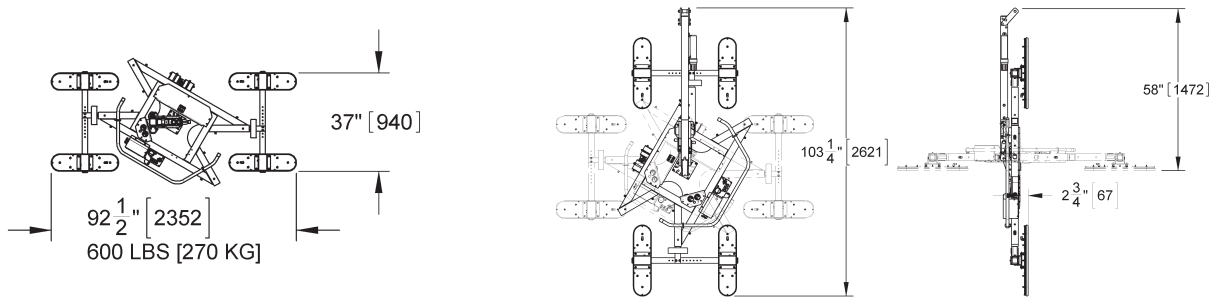

Accommodates panels over 55 ft [17 m] with option 97464 (maximum size shown - smaller configurations possible)

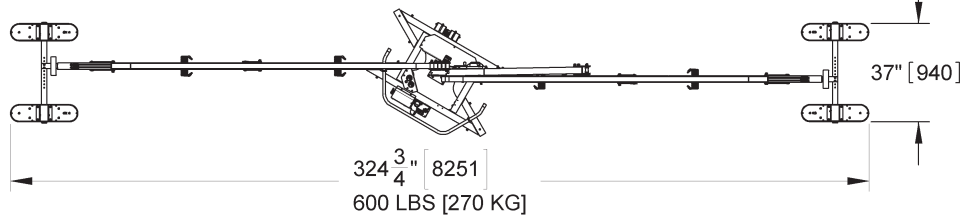

Accommodates panels over 60 ft [18.5 m] with the following options: 97463, 97464 and 97465 (note: must have second set of T-Arms in this configuration).

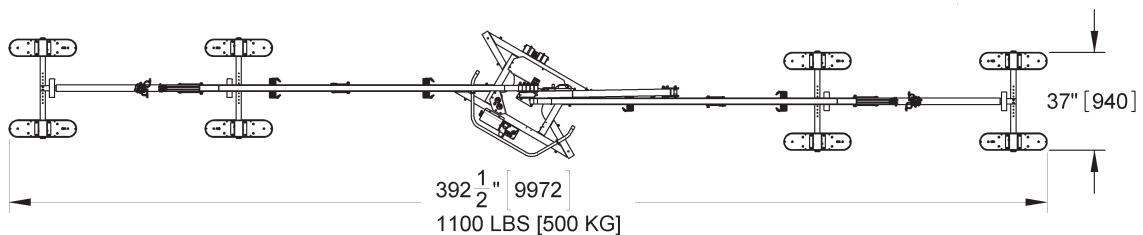
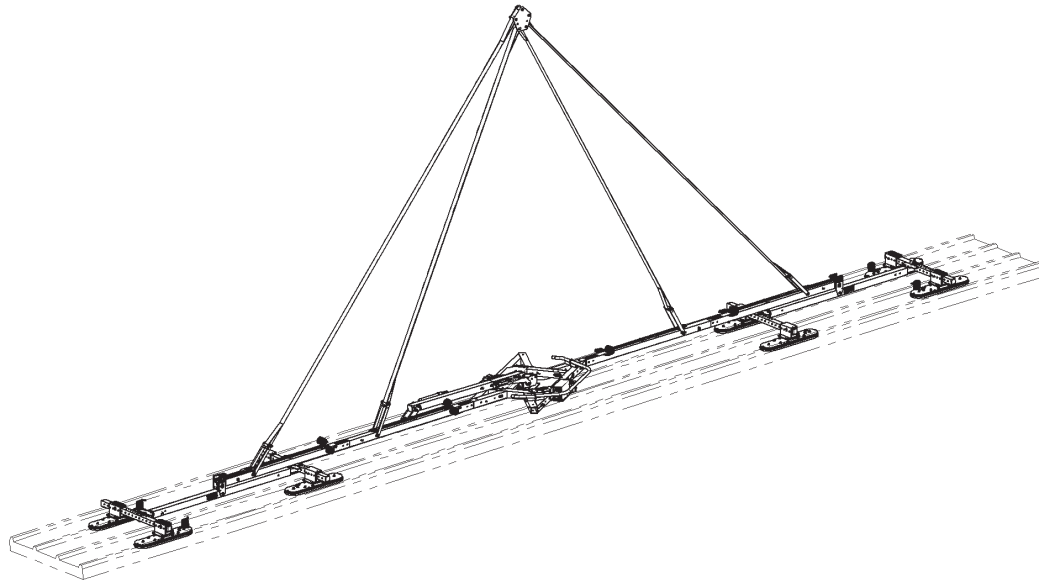

\* FOR LIFTING LOADS IN FLAT ORIENTATION ONLY.

## MRTALP410TDC3

<b>Available Options</b>	Pad frame T-arm assemblies (97465HV) Extensions for movable pad mounts (93100 & 93100AM) Alternative pad compounds for low-marking, heat resistant and coated surface applications.
<b>Standard Pad Spread</b>	Maximum: 45" x 78" [114 cm x 198 cm] Minimum: 25" x 78" [64 cm x 198 cm]
<b>Lifter Weight</b>	250 lbs [114 kg]
<b>Number / Size of Pads</b>	4 / 10" [25 cm] diameter vacuum pads with replaceable sealing rings

## OPTIONAL PAD FRAME CONFIGURATIONS & CAPACITIES WITH VPFS10T PADS

Accommodates panels over 35 ft [10.5 m] in the standard configuration (maximum size shown - narrower configurations possible)

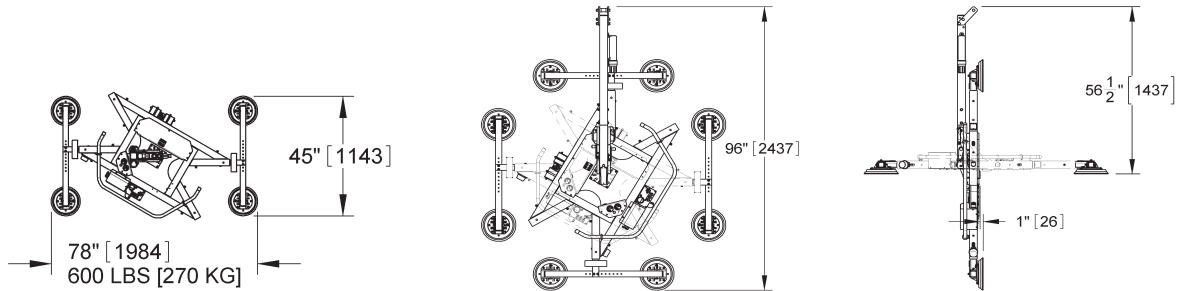

Accommodates panels over 55 ft [17 m] with option 97464 (maximum size shown - smaller configurations possible)

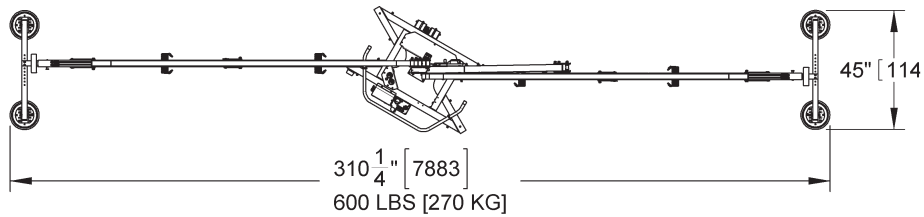

Accommodates panels over 60 ft [18.5 m] with the following options: 97463, 97464 and 97465HV  
(note: must have second set of T-Arms in this config).

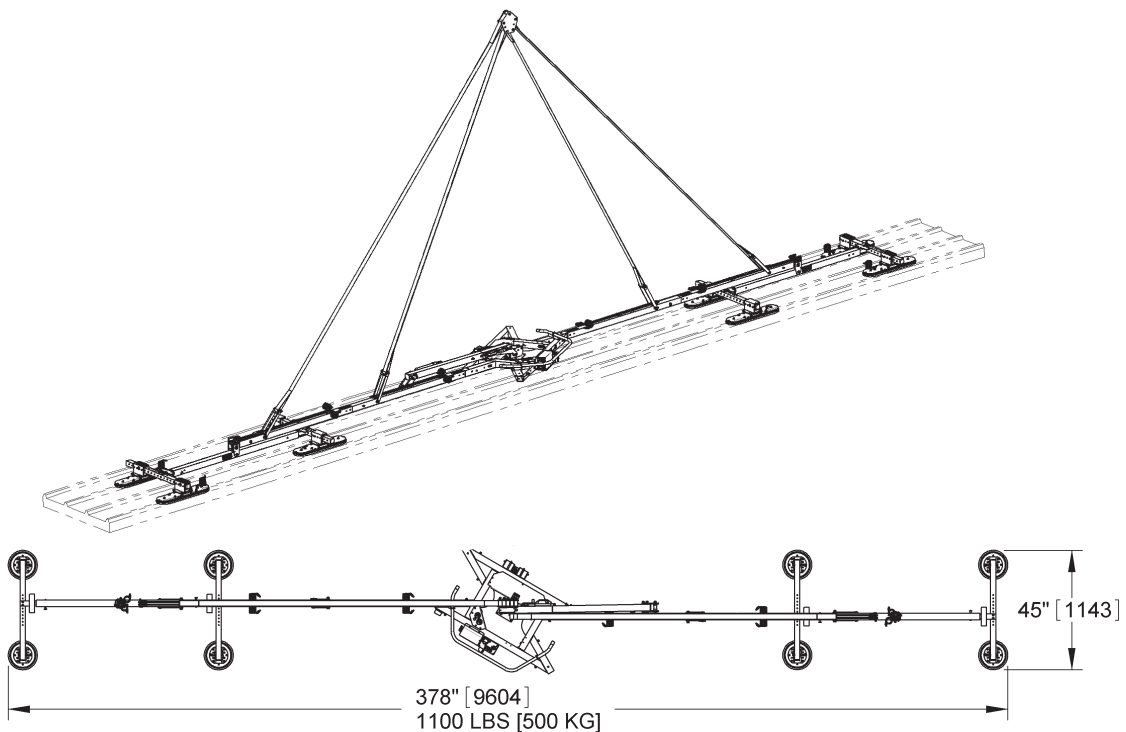

\* FOR LIFTING LOADS IN FLAT ORIENTATION ONLY.

