

KEEP FOR FUTURE REFERENCE



**908 West Main St – P.O. Box 368
Laurel, MT USA 59044
406-628-8231 (phone)
800-548-7341 (phone)
406-628-8354 (fax)**

OPERATING INSTRUCTIONS



**MODEL NUMBERS: MRTALP4625DC3,
MRTALP410TDC3**

SERIAL NUMBER: _____
(please see serial label and record number here)

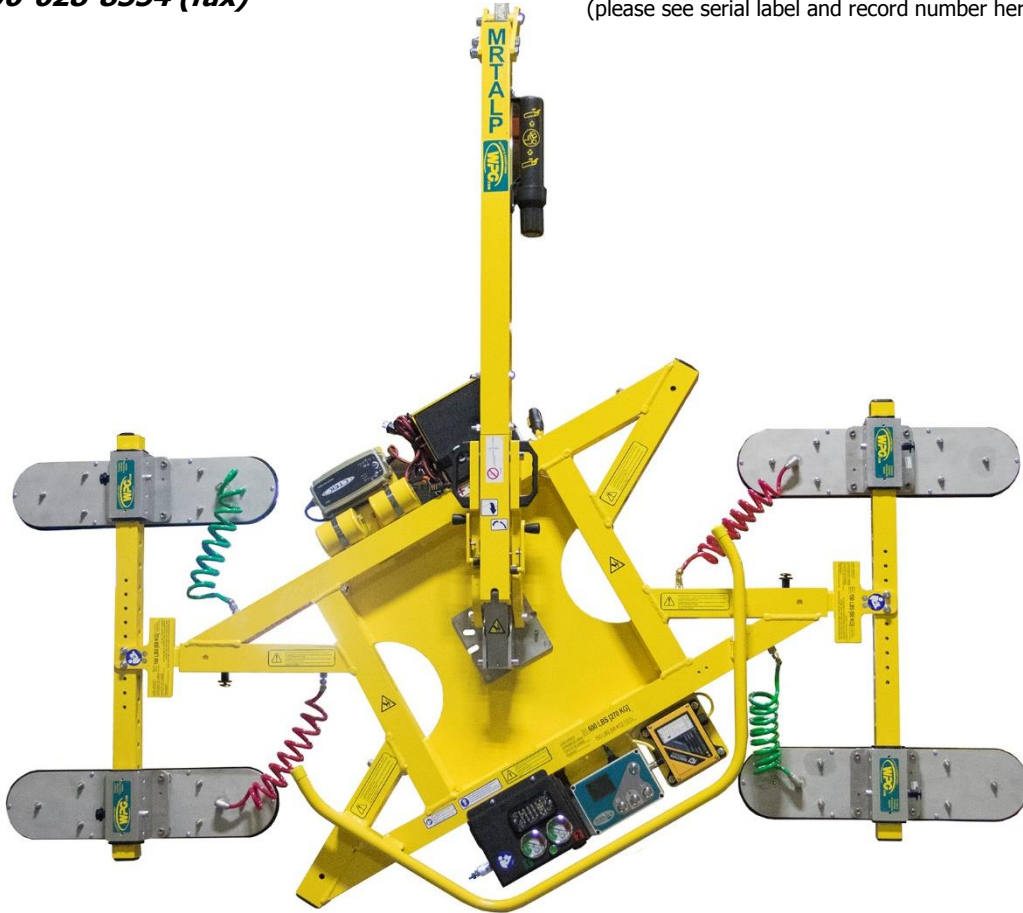

**LOW-PROFILE MANUAL ROTATOR / TILTER 600
DC-VOLTAGE, WITH INTELLI-GRIP® TECHNOLOGY
& PAD FRAME T-ARM ASSEMBLIES
(AVAILABLE WITH REMOTE CONTROL SYSTEM)**



***READ ALL INSTRUCTIONS AND SAFETY RULES
BEFORE OPERATING THIS LIFTER***



DESIGNED FOR MATERIALS HANDLING PROFESSIONALS

TABLE OF CONTENTS

SPECIFICATIONS	3
SAFETY	4
OPERATING FEATURES	5
ASSEMBLY	6
TO INSTALL/REMOVE T-ARM ASSEMBLIES	7
TO INSTALL/REMOVE VACUUM PADS	8
TO POSITION VACUUM PADS	8
TO REPOSITION THE T-ARM CROSS MEMBERS	8
Connecting/Disconnecting Vacuum Hoses.....	9
INTENDED USE	10
LOAD CHARACTERISTICS	10
OPERATING ENVIRONMENT	10
DISPOSAL OF THE LIFTER	11
OPERATION	12
BEFORE USING THE LIFTER	12
Taking Safety Precautions	12
Selecting a Screen Language	12
Performing Inspections and Tests	13
Preparing to Use the Remote Control System	13
TO ATTACH THE PADS TO A LOAD	14
Positioning the Lifter on the Load	14
Powering up the Lifter.....	15
Sealing the Pads on the Load	16
Reading the Vacuum Gauges.....	16
Vacuum Level on Optimal Surfaces.....	17
Vacuum Level on Other Surfaces	17
TO LIFT AND MOVE THE LOAD	18
About the Tilt Linkage	18
Interpreting the Lift Light	18
Watching Vacuum Indicators	18
Controlling the Lifter and Load.....	19
In Case of Power Failure	19
TO ROTATE THE LOAD	20
TO TILT THE LOAD	21
TO RELEASE THE PADS FROM THE LOAD	22
AFTER USING THE LIFTER	23
Storing the Lifter.....	23

MAINTENANCE 24

INTELLI-GRIP® DIAGNOSTIC CODES.....24

INSPECTION SCHEDULE28

 Infrequent Use 29

TESTING30

 Operational Tests 30

 Load Test 30

12-VOLT BATTERY ASSESSMENT30

12-VOLT BATTERY RECHARGE31

NOTIFICATION BUZZER BATTERY TEST31

VACUUM PAD MAINTENANCE32

 Pad-to-Load Friction Coefficient 32

 Pad Inspection..... 32

 Pad Cleaning..... 32

VACUUM TEST33

REMOTE CONTROL SYSTEM TEST33





















TO REPLACE SEALING RING IN VPFS10T PADS34

TO REPLACE PAD INSERTS IN VPFS625 PADS35

REPLACEMENT PARTS LIST 37

LIMITED WARRANTY 38

SAFETY

-  Wear personal protective equipment that is appropriate for the load material. Follow trade association guidelines.
-  Use the lifter only in an approved OPERATING ENVIRONMENT (see INTENDED USE).
-  Do not use a lifter that is damaged, malfunctioning, or missing parts.
-  Do not use a lifter if the sealing edge of any vacuum pad is cut or otherwise damaged.
-  Do not remove or obscure safety labels.
-  Do not use a lifter if the Maximum Load Capacity or any safety label appears to be missing or obscured. 
-  Make sure the contact surfaces of the load and vacuum pads are clean before attaching the lifter (see MAINTENANCE).
-  Do not exceed the Maximum Load Capacity or lift loads the lifter is not designed for (see INTENDED USE). 
-  Do not lift cracked or broken glass.
-  Position the vacuum pads correctly on the load before lifting (see OPERATION).
-  Do not lift a load if any vacuum indicator shows inadequate vacuum (see OPERATION).
-  Do not touch the vacuum release controls during a lift.
-  Do not allow people to ride on the lifter or the load.
-  Do not lift a load higher than necessary or leave suspended loads unattended.
-  Do not position a loaded or unloaded lifter over people.
-  Keep unauthorized personnel away from the lifter, to avoid injury in case of an unintended load release.
-  Before servicing the lifter, place the power control in the inactive position and, when possible, disconnect the power source (only applicable to powered lifters).
-  Do not make any modifications to the lifter (see LIMITED WARRANTY).

OPERATING FEATURES

Features shown here are underlined> on their first appearance in each section following.

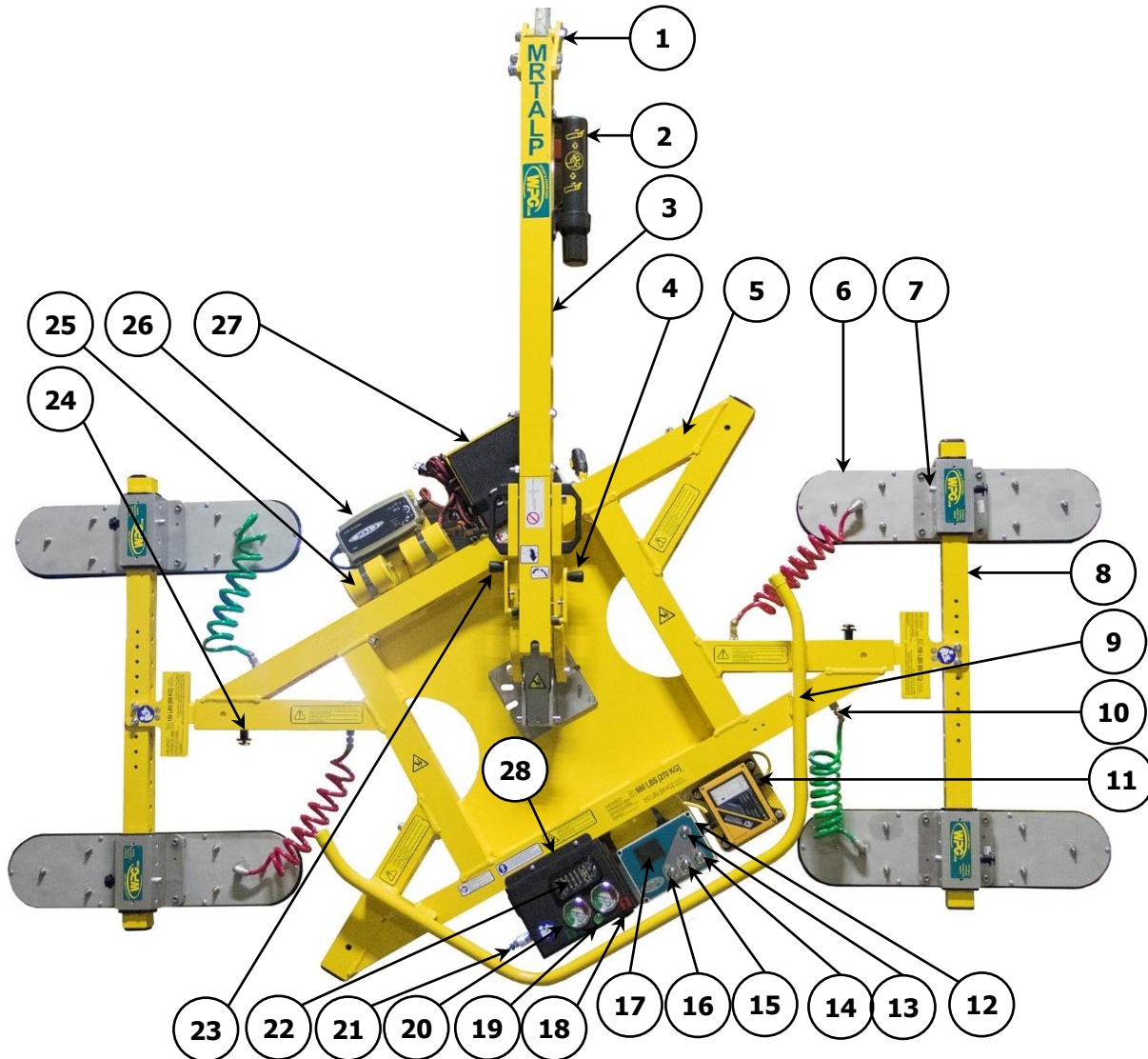

- | | | |
|-----------------------------|----------------------------------|--|
| 1 LIFT POINT | 11 RADIO RECEIVER (optional) | 21 AIR FILTERS |
| 2 INSTRUCTIONS CANISTER | 12 INTELLI-GRIP® CONTROL UNIT | 22 STROBE LIGHT |
| 3 LIFT BAR | 13 "POWER" BUTTON | 23 TILT RELEASE LEVER |
| 4 ROTATION RELEASE LEVER | 14 "RELEASE" BUTTON | 24 COTTERLESS HITCH PIN |
| 5 PAD FRAME | 15 "ATTACH" BUTTON | 25 VACUUM RESERVE TANKS |
| 6 VACUUM PAD | 16 "FUNCTION" BUTTON | 26 BATTERY CHARGER |
| 7 SLIDING/MOVABLE PAD MOUNT | 17 LCD SCREEN with BATTERY GAUGE | 27 BATTERY |
| 8 PAD FRAME T-ARM ASSEMBLY | 18 NOTIFICATION BUZZER | 28 Cover for VACUUM PUMP,
CIRCUIT BOARD and
VACUUM SENSORS |
| 9 CONTROL HANDLE | 19 VACUUM LIFT LIGHT | |
| 10 QUICK CONNECTOR | 20 VACUUM GAUGES | |

Note: Although some of the following photos do not show this specific lifter, they all illustrate how this kind of lifter functions.

ASSEMBLY

- 1) Remove all vacuum lifter restraints and save them with the shipping container for future use.
- 2) If necessary, assemble the lift bar as shown. Tighten both bolts (2) securely.

- 3) Adjust the lift point to optimize the lifter's hang angle:
 - 3.1) Remove the retaining bolt (3) and loosen the pivot bolt (4).
 - 3.2) Move the lift point to the appropriate position.
 - 3.3) Reinstall the retaining bolt and tighten both bolts securely.

Note: Position the lift point to avoid contact with long configurations of the pad frame during rotation.

- 4) Suspend the lifter from appropriate hoisting equipment:

- 4.1) Select a crane and/or hoist rated for the Maximum Load Capacity plus the Lifter Weight.

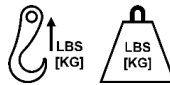

Note: Any lifter use must comply with all statutory or regulatory standards for hoisting equipment in your region.

- 4.2) Disengage the tilt latch and raise the lift bar.



- 4.3) Attach the hoisting hook to the lift point.



Make sure hook has restraining latch (circled).

Note: Make sure the hook does not interfere with the load, using rigging as needed.



Only use rigging rated for Maximum Load Capacity plus Lifter Weight.



- 4.4) Use the hoisting equipment to remove the lifter from the shipping container. Avoid damaging the vacuum pads.

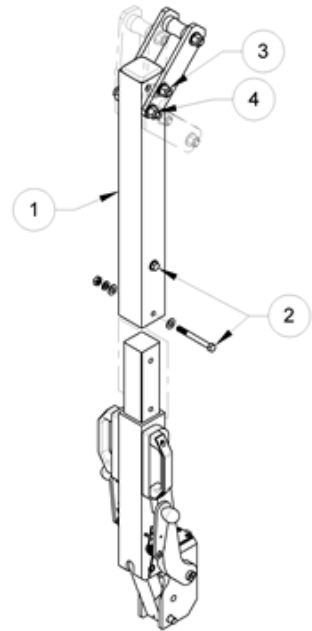

5) Connect the electrical connectors.

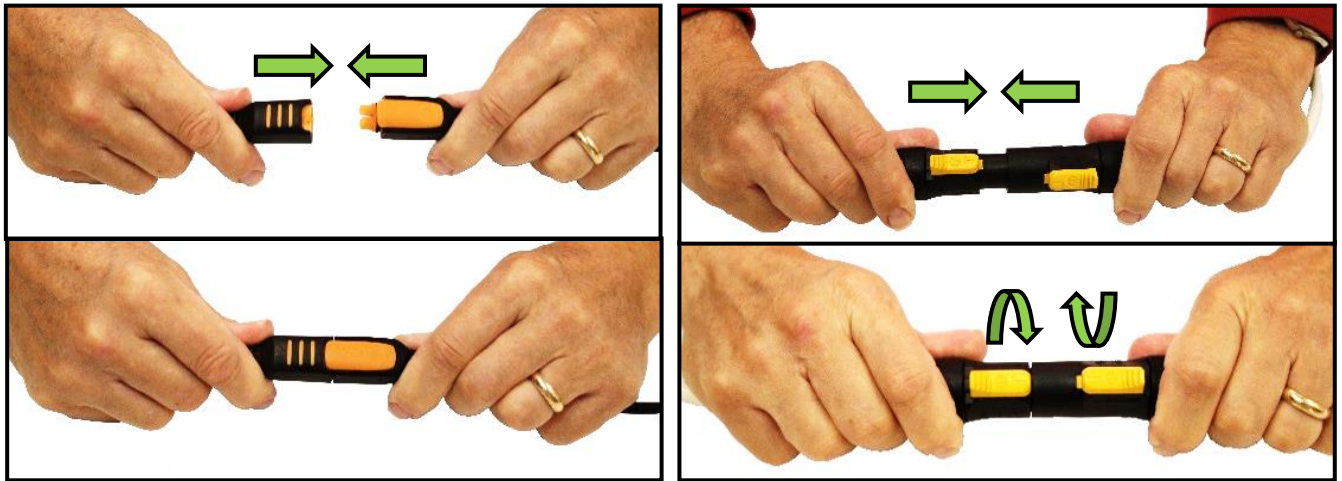

Install the 9-volt battery for the notification buzzer as directed in the NOTIFICATION BUZZER BATTERY TEST (see MAINTENANCE).

6) Assemble the pad frame for optimal load support (see next section). Remove the pad covers and save them for future use (if applicable).



7) Before you place the lifter in service, perform Operational and Load Tests (see MAINTENANCE).

TO INSTALL/REMOVE T-ARM ASSEMBLIES

- 1) Insert a T-arm assembly into the pad frame.
- 2) Use a cotterless hitch pin to secure the T-arm.
- 3) Install the second T-arm assembly likewise.

Note: Always position T-arms as shown in OPERATING FEATURES.

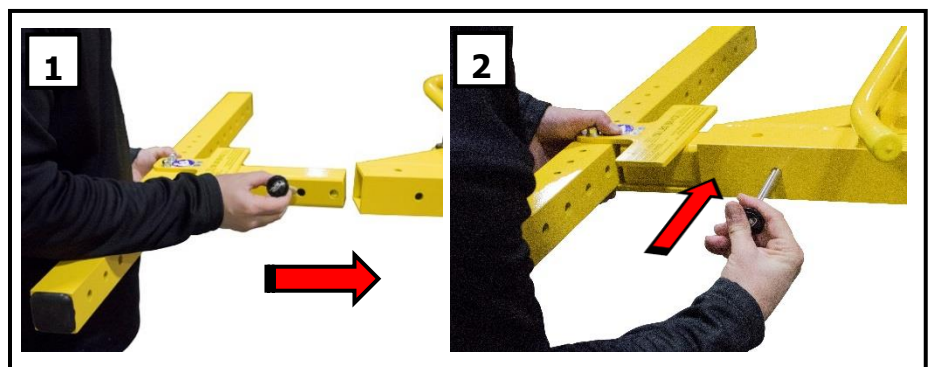

To remove the T-arm assemblies, reverse these steps. Store removed components in a clean, dry location.

To INSTALL/REMOVE VACUUM PADS

- 1) Position a sliding/movable pad mount on the T-arm assembly.
- 2) Use the cotterless hitch pin to secure the pad mount.
- 3) Install the other pad mounts likewise.

Notes: Use only 2 pads on each T-arm assembly. Pads must be arranged symmetrically, to keep the lifter balanced.

To remove vacuum pads, reverse these steps. Store removed components in a clean, dry location.

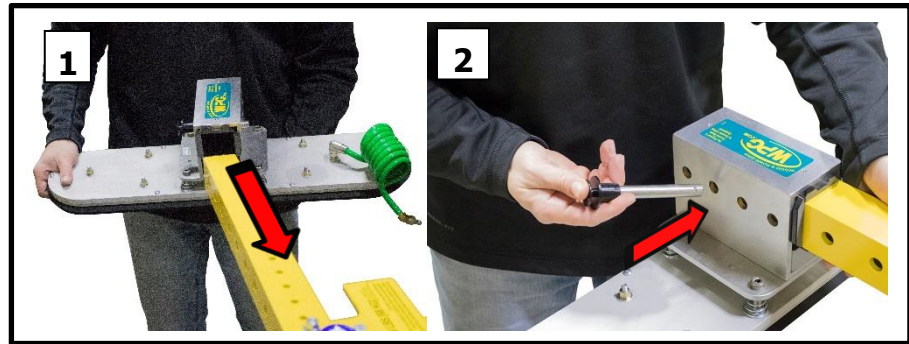

To POSITION VACUUM PADS

- 1) Remove the cotterless hitch pin that secures a sliding/movable pad mount to the pad frame.
- 2) Position the pad mount as required on the T-arm assembly.

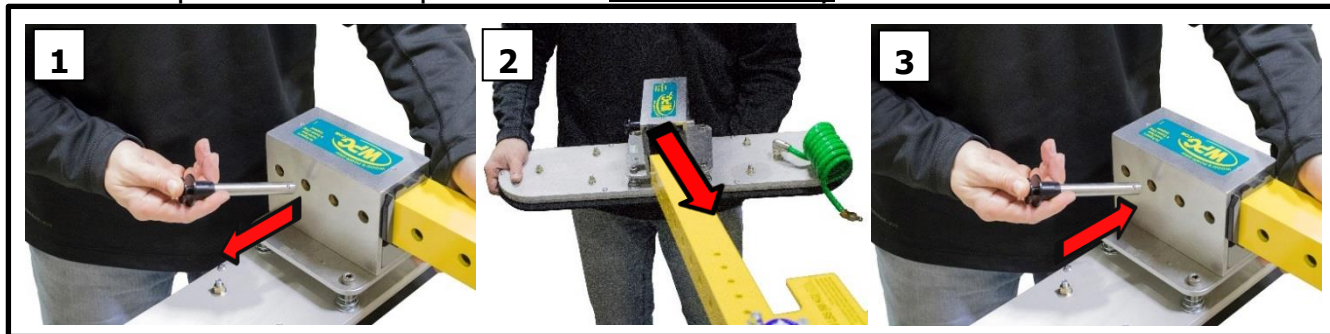

- 3) Use the cotterless hitch pin to secure the pad mount.
- 4) Repeat these steps to position other pad mounts as needed.

Note: Use only 2 pads on each T-arm assembly. Pads must be arranged symmetrically, to keep the lifter balanced.

To REPOSITION THE T-ARM CROSS MEMBERS

To adjust the pad alignment more precisely, reposition the cross members of the T-arm assemblies:

- 1) Remove the bolts connecting a cross member.
- 2) Move the cross member to the appropriate position.
- 3) Reinstall the bolts and tighten them securely.
- 4) Repeat these steps to reposition the other cross member.

Connecting/Disconnecting Vacuum Hoses

- To connect a vacuum hose, push the male and female ends of the quick connector together until they lock.



Make sure quick connectors seal completely and all vacuum hoses function correctly.

- To disconnect the vacuum hose, move the release ring on the female end until the quick connector separates.

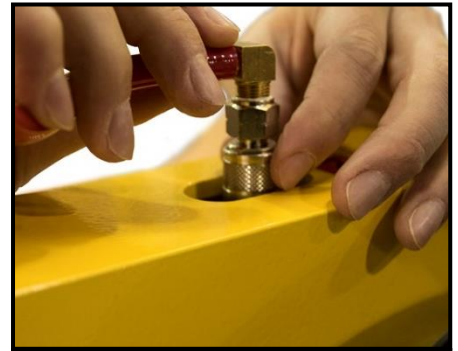

Make sure the hoses are connected correctly (green to circuit "1" and red to circuit "2").



Note: The 2 vacuum circuits correspond with their matching vacuum gauges.





INTENDED USE

LOAD CHARACTERISTICS

 **Do NOT lift explosives, radioactive substances or other hazardous materials.**

Make sure the vacuum lifter is intended to handle each load, according to these requirements:

- The load weight must not exceed the Maximum Load Capacity. 
- The load must be a single piece of relatively nonporous material with a flat and relatively smooth contact surface. Flexible sealing rings can accommodate some surface relief, provided contour changes are not too abrupt. To determine whether the load is too porous or rough, perform a Load Suitability Test as directed in To Attach the Pads to a Load (see OPERATION).
- The load's contact surface must be able to obtain a friction coefficient of 1 with the lifter's vacuum pads, or capacity should be derated appropriately (see MAINTENANCE).
- The load's surface temperature must not exceed the Operating Temperatures.⁵ 
- The load's *minimum* length and width are determined by the Pad Spread (see SPECIFICATIONS).
- The load's *maximum* length and width are determined by the allowable overhang.⁶
- 8" [20 cm] is the allowable thickness of loads at the Maximum Load Capacity.⁷ 

Note: Standard vacuum pads can stain or deform load surfaces with light colors or soft coatings. Test such surfaces for damaging effects before using the lifter on them.⁸

OPERATING ENVIRONMENT

Make sure the vacuum lifter is intended for use in each work environment, given the following restrictions:

 **Never use lifter in dangerous environments.**

- This lifter is not intended for any environment that is dangerous to the operator or damaging to the lifter. Avoid environments containing explosives, caustic chemicals and other dangerous substances.

⁵ Vacuum pads made from a heat-resistant rubber compound can enable you to lift loads with higher surface temperatures. Contact Wood's Powr-Grip or an authorized dealer for more information.

⁶ The allowable overhang is the amount of load material that can extend sideways beyond the vacuum pads without breaking or otherwise being damaged. This depends on the load material, its thickness, and the angle of handling (if any). Since every material has different physical properties, the allowable overhang must be evaluated separately for each load type. Contact Wood's Powr-Grip or an authorized dealer for more information.

⁷ However, the allowable thickness increases as load weight decreases. Contact Wood's Powr-Grip for more information.

⁸ Alternative rubber compounds are available for these purposes. Contact Wood's Powr-Grip or an authorized dealer for more information.

- The work environment is limited by the Maximum Operating Elevation and Operating Temperatures.

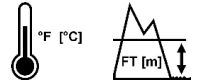

Metal particles and similar environmental contaminants could result in vacuum pump failure.

- The lifter is not designed to be watertight: Do not submerge the lifter or use it in unsuitable weather.



By reducing slip resistance of vacuum pads, moisture can result in reduced lifting capacity.

DISPOSAL OF THE LIFTER

After the Service Life of the vacuum lifter has ended (see SPECIFICATIONS), dispose of it in compliance with all local codes and applicable regulatory standards.

Note: Special disposal regulations may apply to the battery.

OPERATION

BEFORE USING THE LIFTER

Determine whether the vacuum lifter is capable of each intended task (see SPECIFICATIONS and INTENDED USE). Then complete the following preparations:

Taking Safety Precautions



Read all directions and safety rules before using lifter.

- Be trained in all industry and regulatory standards for lifter operation in your region.



Always wear appropriate personal protective equipment.

- Follow trade association guidelines about precautions needed for each load material.

Selecting a Screen Language

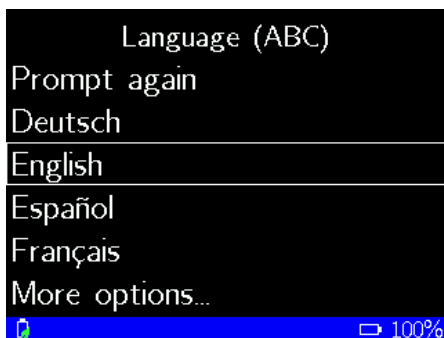

When the lifter is powered up for the first time, the Intelli-Grip® Control Unit prompts the operator to select a language for the LCD screen.

To scroll down, press the “release” button (|→|).

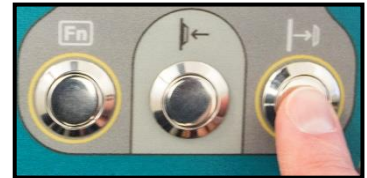

To scroll up, press the “attach” button (|←|).



To select a language, press the “function” button (Fn).⁹



Note: A similar process is used to navigate all menus.

⁹ To change the language again, refer to the INTELLI-GRIP® OPERATOR MENUS section of the *SERVICE MANUAL*.

Performing Inspections and Tests

 **Always check battery energy before using lifter**
(see MAINTENANCE).

- Follow the INSPECTION SCHEDULE and TESTING (see MAINTENANCE).
- Always perform a VACUUM TEST before placing a lifter in service (see MAINTENANCE).
- **Examine air filters regularly and service when needed.**

Service the 2 air filters whenever a bowl contains liquid or other contaminants, or an element appears dirty (see AIR FILTER MAINTENANCE in *SERVICE MANUAL*).

 **Make sure notification buzzer can be heard over noise at operator position.**

- Make sure the notification buzzer is clearly audible at the maximum distance between the operator and the lifter, despite any barriers or obstacles.¹⁰ The VACUUM TEST provides a convenient opportunity to check this (see MAINTENANCE).

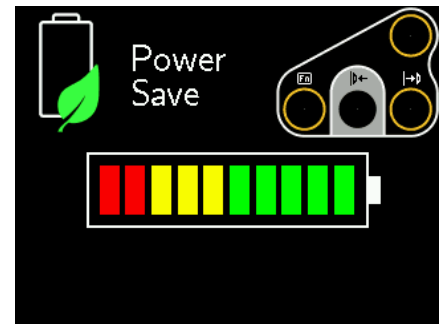

Preparing to Use the Remote Control System

 This optional radio receiver and radio transmitter enable you to activate the lifter's "attach" and "release" functions at distances up to 250' [76 m], provided you have a clear and direct view of the lifter and its status indicators.

To operate a lifter remotely, follow these safety rules:

- Visually verify the status of the lifter and load before lifting.

 **Make sure nearby personnel are aware of intended remote control actions.**

- Monitor the lifter at all times to make sure it is functioning as intended.¹¹
- Be sure the load is landed and supported correctly before releasing it (see following sections).

Note: To prevent any radio transmission, press the emergency transmitter disconnect button.¹²



- 1 EMERGENCY TRANSMITTER DISCONNECT
- 2 TRANSMISSION INDICATOR LIGHT
- 3 "RELEASE" BUTTON
- 4 TRANSMITTER POWER/"FUNCTION" BUTTON
- 5 "ATTACH" BUTTON

¹⁰ Maximum buzzer volume is 95 dBA at 2' [60 cm]. If applicable, consult EN 7731 to make sure the notification buzzer complies with CE Standards.

¹¹ The Remote Control System is designed to prevent multiple lifters from responding. Nevertheless, radio controlled lifters should be tested to make sure each transmitter controls only one lifter.

¹² To reset the emergency disconnect, twist the button clockwise and allow it to spring outward to its original position.

TO ATTACH THE PADS TO A LOAD

Positioning the Lifter on the Load

- 1) Make sure that the contact surfaces of the load and the vacuum pads are clean (see MAINTENANCE).



Attach lifter to load as directed below. Failure to follow instructions can result in load damage or personal injury.



- 2) Attach the lifter to the load "on center" or "above center", as required:
 - To rotate and tilt loads normally, center the pad frame on the load ("on center").¹³



- To tilt loads lengthwise from the flat to upright orientation, center the pad frame from left to right on the load, and position the vacuum pads toward what will be the top end when upright ("above center"). The load will automatically tilt to the upright position when lifted.

- 3) Make sure all vacuum pads will fit on the load and will be loaded evenly. When applicable, consult the Per-Pad Load Capacity.
- 4) Place the vacuum pads in contact with the load surface.



¹³ The lifter is designed to handle the maximum load weight when the load's center of gravity is positioned within 2" [5 cm] of the lifter's rotation axis. Off-center loads may rotate or tilt unexpectedly.

Powering up the Lifter

Press the lifter's power button (⏻).

The vacuum pump will run for a few seconds, as a normal function of the Intelli-Grip® self-diagnostics.



 To use the Remote Control System, hold the transmitter power button (⏻) briefly to activate the radio transmitter.¹⁴

Note: When you hold any button on the transmitter, the transmission indicator light flashes green if the transmitter is activated or red if it is not activated.



¹⁴ The radio transmitter turns off automatically, after a period of inactivity.

Sealing the Pads on the Load

Press the "attach" button (↵←) on the lifter.



Keep "attach" function activated throughout lift.



To use the Remote Control System, press the "attach" button (↵←) on the radio transmitter.



The vacuum pump will run until the vacuum pads seal completely. If the lifter takes too long to attach, the notification buzzer chirps and the LCD screen displays "Vacuum not increasing normally", along with a diagnostic code (see MAINTENANCE). In this case, press the lifter firmly against the load to help the pads begin to seal.¹⁵

Reading the Vacuum Gauges

Two vacuum gauges show the current vacuum level in positive inches of Hg and negative kPa for the dual vacuum system:

- **Green** range: Vacuum level is sufficient to lift the maximum load weight (figure B1).
- **Red** range: Vacuum level is **not** sufficient to lift the maximum load weight (figure B2).

If it takes more than 5 seconds for the vacuum level to reach 5" Hg [-17 kPa] on either vacuum gauge, press on any vacuum pad that has not yet sealed.



¹⁵ Although a vacuum pad may become distorted during shipping or storage, this condition should correct itself with continued use.

Vacuum Level on Optimal Surfaces

When the lifter is attached to *clean, smooth, nonporous* surfaces, it should be able to maintain sufficient vacuum for lifting, except when used above the Maximum Operating Elevation.

If it does not, check for faults in the vacuum generating system (see MAINTENANCE: VACUUM TEST).



Vacuum Level on Other Surfaces

When the lifter is attached to *contaminated, rough or porous* surfaces, it may not be able to maintain sufficient vacuum for lifting, due to leakage at the vacuum pads.¹⁶ In this case:

- Thoroughly clean the load surface and the vacuum pads (see MAINTENANCE).
- When necessary, perform a Load Suitability Test:
 - 1) Make sure the vacuum generating system is functioning correctly (see MAINTENANCE).
 - 2) Attach the vacuum pads to the load as previously directed.
 - 3) After the vacuum pump stops running, hold the "function" button (**Fn**) and the "power" button (⏻) for at least 5 seconds to power down the lifter.

Note: During this time the LCD screen displays "WARNING! Is load attached?", the notification buzzer chirps rapidly and the strobe light flashes.
 - 4) Raise the load a minimal distance, to make sure it is supported by the lifter.



Take precautions in case load should fall during test.

- 5) Watch each vacuum gauge for 5 minutes: ***The lifter must maintain a minimum vacuum level of 10" Hg [-34 kPa].*** If not, the load is not suitable for this lifter.¹⁷
- 6) Lower the load after 5 minutes or whenever the vacuum level is less than 10" Hg [-34 kPa].

¹⁶ Contaminated loads can also cause the vacuum pump to run frequently or continuously. Since excessive pumping quickly reduces battery energy, clean the load whenever possible.

¹⁷ Certain load materials are too rough or porous to pass this test. However, where CE Standards do not apply, the lifter may be allowed to lift such loads. Contact Wood's Powr-Grip for more information.

TO LIFT AND MOVE THE LOAD

 ***Lift bar must be vertical to lift load.***

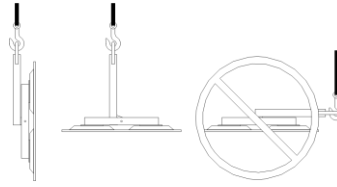

About the Tilt Linkage

 ***Unbalanced loads may tilt unexpectedly during lifter operation.***

The tilt linkage minimizes operator effort and automatically holds a balanced load in either the upright or the flat position. However, an unbalanced load may tilt unexpectedly, resulting in load damage or personal injury.

 ***Make sure load is positioned correctly on lifter.***

To minimize these risks, make sure **before lifting any load** that it has appropriate LOAD CHARACTERISTICS (see INTENDED USE) and is attached correctly to the lifter as previously directed.

Interpreting the Lift Light

 When the vacuum lifter is ready to lift the Maximum Load Capacity, the vacuum lift light turns *on* automatically and the vacuum pump turns *off* temporarily, to conserve battery energy.



 ***Never lift load unless lift light is illuminated, because premature lifting could result in load release and personal injury.***

Watching Vacuum Indicators

Watch the vacuum lift light and both vacuum gauges throughout the entire lift.

 ***Make sure vacuum indicators remain completely visible.***

The vacuum pump turns on and off to overcome any leakage. However, if the leak rate is greater than normal, the notification buzzer chirps and the LCD screen displays "Vacuum decrease on circuit #", along with a diagnostic code.¹⁸ Such leaks can cause the battery to be discharged more quickly, reducing the lifter's operating time. To prevent this, review the section TO ATTACH THE PADS TO A LOAD: Vacuum Level on Other Surfaces.



If the vacuum level decreases to less than 16" Hg [-54 kPa] on either gauge, the notification buzzer sounds continuously, the lift light turns off, and the LCD screen displays "INSUFFICIENT VACUUM!", along with a diagnostic code (see MAINTENANCE). If this happens:

1) Keep everyone away from a suspended load until it can be safely lowered to a stable support.

 ***Stay clear of any suspended load while indicators warn of low vacuum.***

¹⁸ Automatic leak detection is **not** a substitute for performing the VACUUM TEST, as required by the INSPECTION SCHEDULE and TESTING (see MAINTENANCE).

- 2) Stop using the lifter until the cause of the vacuum loss is identified:
 - Inspect the vacuum pads for damage and perform the VACUUM TEST (see MAINTENANCE).
 - When necessary, inspect the entire vacuum generating system.
- 3) Correct any faults before resuming normal operation of the lifter.

Controlling the Lifter and Load

When the lifter is ready, use the hoisting equipment to raise the lifter and load as needed.

Use a control handle to keep the lifter and load in the required position.

Once there is enough clearance, you may reposition the load as required (see OPERATION).



In Case of Power Failure

In the event of a failure in the battery or electrical system, the notification buzzer sounds continuously.



Stay clear of any suspended load during power failure.

Although the vacuum reserve tanks are designed to support the load for at least 5 minutes without power, this depends on many factors, including the condition of the vacuum pads and the LOAD CHARACTERISTICS (see MAINTENANCE and INTENDED USE).

If a power failure occurs, keep everyone away from a suspended load until it can be lowered safely to a stable support. Correct any faults before resuming normal operation of the lifter.

TO ROTATE THE LOAD



Never disengage rotation and tilt latches at the same time, because this could result in load damage or personal injury.



Make sure load is positioned correctly on lifter (as previously directed).



Never rotate load that is oriented in flat position.



Never rotate load when lifter is attached "above center" (see To ATTACH).

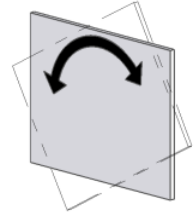

- 1) Latch the pad frame in the vertical position (see next section).
- 2) Make sure the load has enough clearance to rotate without contacting anyone or anything.
- 3) Use the control handle to keep the load under control at all times.



Unbalanced loads may rotate unexpectedly when latch is disengaged.

- 4) Pull the rotation release lever to disengage the rotation latch, and rotate the load as required.



- 5) To stop load motion, let go of the rotation release lever and guide the load to the next appropriate stop.

Note: Whenever rotation is not required, keep the rotation latch engaged, to prevent load damage or personal injury.

TO TILT THE LOAD

 **Never disengage rotation and tilt latches at the same time, because this could result in load damage or personal injury.**

 **Make sure load is positioned correctly on lifter** (as previously directed).

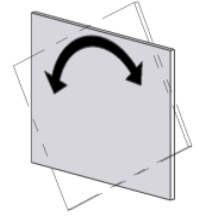

- 1) Make sure the load has enough clearance to tilt without contacting anyone or anything.
- 2) Use the control handle to keep the load under control at all times.



Unbalanced loads may tilt unexpectedly when latch is disengaged.

- 3) If the pad frame is latched, pull the tilt release lever to disengage the tilt latch.

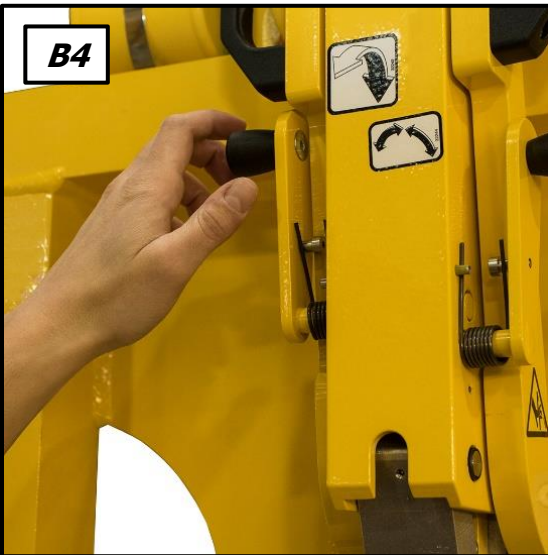

 **Always keep hands and fingers away from bars of tilt linkage.**

- 4) Lift upward or press downward on the control handle to tilt the load as required.¹⁹

Note: See INTENDED USE: LOAD CHARACTERISTICS about allowable overhang.

A load with overhang may force you to release the handle as the load approaches the flat position. In this case, use hand cups or other appropriate means to control the load.



Note: The pad frame automatically latches in place when it returns to the vertical position.

¹⁹ Due to the tilt linkage design, load force on the control handle changes direction during the tilt.

TO RELEASE THE PADS FROM THE LOAD



Make sure load is at rest and fully supported before releasing vacuum pads.

- 1) Hold the “function” button (**Fn**) and the “release” button (**|→**) to break the vacuum seal. If not, follow the directions on the LCD screen.



- To use the Remote Control System, hold the “function” button (**|→**) and the “release” button (**|→**) on the radio transmitter, to break the vacuum seal.

Note: The strobe light flashes while the “function” or “release” button is held, to show the operator that signals are being transmitted and to warn others that the operator is releasing the load.

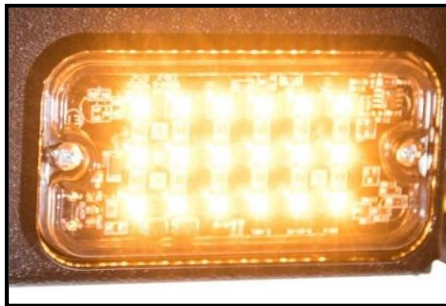

- 2) Continue to hold the “function” and “release” buttons until the vacuum pads release the load completely. Otherwise, the lifter will automatically revert to “attach” mode.²⁰





Do not move lifter until pads release completely, because such movement could result in load damage or personal injury.

After the load is successfully released, the lifter activates the “power save” mode automatically.

- 3) Before you lift another load, perform the Every-Lift Inspection (see MAINTENANCE).

²⁰ A “Timed Release” function can be used to help separate the lifter from the load: Hold the “function” and “release” buttons until a yellow arrow appears on the LCD screen. Then tap the “function” button 2 or more times. This extends the release mode for 5 seconds per each additional tap.

AFTER USING THE LIFTER

- 1) Press the power button () and the "function" button () to power down the vacuum lifter.

Caution: Do not set lifter on surfaces that could soil or damage vacuum pads.

- 2) Use the hoisting equipment to lower the lifter gently onto a stable support. Then detach the hoisting hook from the lift point.
- 3) To transport the lifter, secure it in the original shipping container.



Storing the Lifter

- 1) Use the covers supplied to keep the vacuum pads clean.

!!-CE-!! To prevent the lifter from tipping over on relatively horizontal surfaces, place the vacuum pads face-down on a clean, smooth, flat surface. Then lower the lift bar and place a support under the lift point.

- 2) Charge the battery completely and repeat every 6 months (see MAINTENANCE).
- 3) Disconnect the electrical connectors to prevent battery discharge.

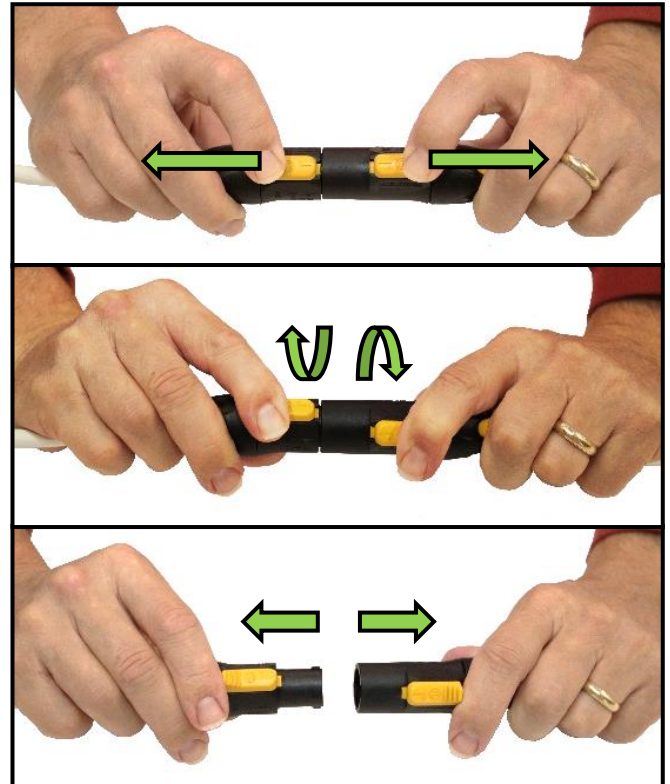
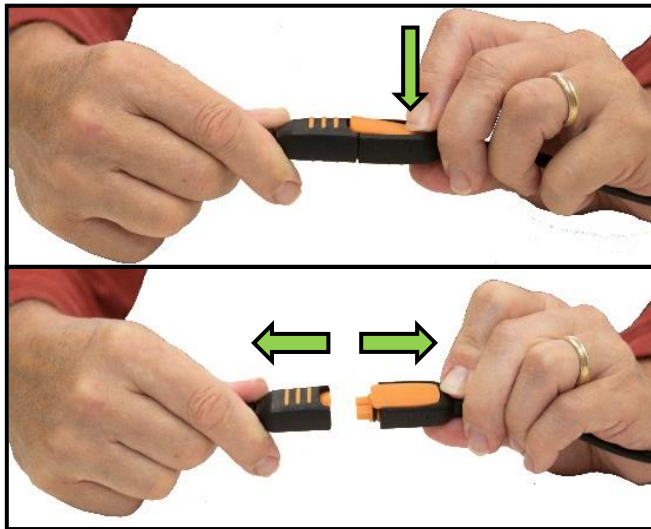

- 4) Store the lifter in a clean, dry location.

Store the battery between 32° and 70° F [0°–21° C]. Avoid storage above 100° F [38° C].

MAINTENANCE





Disconnect battery before servicing lifter.

Note: Refer to **SERVICE MANUAL #36105** when applicable. See final section for wiring diagrams.

INTELLI-GRIP® DIAGNOSTIC CODES

Refer to the following table whenever a diagnostic code appears on the LCD screen. Codes are listed in alphanumeric order. If the Explanations/Directions do not resolve the issue, refer fault(s) to qualified service personnel. Relevant parts are listed in REPLACEMENT PARTS.

Key:  = buzzer sounds  = buzzer sounds continuously  = strobe light flashes

Code	On-Screen Message	Buzzer Pattern	Strobe Light Activity	Explanations/Directions
B00	"Low 12V Battery (#)"	1 chirp every 2 seconds	(none)	Charge 12V <u>battery</u> or, if necessary, replace it (see 12-VOLT BATTERY RECHARGE to follow). Cold battery may need to be warmed and/or charged more often.
B01	"Lockout (low 12V battery) (#)"	continuous	(none)	Once "Power Save" mode is activated, "attach" and "release" functions are prevented because 12V <u>battery</u> energy is insufficient. Charge battery before next lift (see 12-VOLT BATTERY RECHARGE to follow).
B02	"Replace 12V battery?"	1 chirp per minute	(none)	Check condition of 12V <u>battery</u> (see 12-VOLT BATTERY ASSESSMENT and 12-VOLT BATTERY RECHARGE to follow). Since cold battery may prematurely activate this notification, warm battery and retest when appropriate. Replace battery as needed. Note: This notification can be activated in error if <u>battery charger</u> is plugged into power source while lifter is powered up. If so, power down lifter, disconnect charger from power source, and power up again. If code persists, check battery condition as directed above.
B03	"Charge 12V battery soon"	1 chirp per minute	(none)	Charge 12V <u>battery</u> (see 12-VOLT BATTERY RECHARGE to follow).
B09	"Replace 9V battery?"	1 chirp per minute	(none)	Replace 9V battery for <u>notification buzzer</u> as needed (see NOTIFICATION BUZZER BATTERY TEST to follow).
C00	"Fail-safe on module"	continuous	on	Modular <u>circuit board</u> has activated fail-safe mode, to prevent potential injury. Service is required.
C011	"Communication failure, module 1"	fast chirp	(none)	Fault is detected in connection between modular <u>circuit board</u> and <u>control unit</u> . If code does not clear automatically, service is required.
C021	"Internal error, module 1"	continuous	(none)	Fault is detected in modular <u>circuit board</u> . If code does not clear automatically, service is required.
C03	"Firmware updater detected (#)"	(none)	(none)	Service tool is connected. Remove it before resuming lifter use and contact WPG.

Code	On-Screen Message	Buzzer Pattern	Strobe Light Activity	Explanations/Directions
C04	"Module revision not compatible"	1 chirp every 2 seconds	(none)	Make sure lifter is used within Operating Temperatures (see SPECIFICATIONS). Then power lifter down and up again. If code persists, the modular <u>circuit board</u> is incompatible or it has failed. Service is required.
C05	"Module revision lockout"	continuous (while button is held)	(none)	Once "Power Save" mode is activated, "attach" and "release" functions are prevented in connection with Code C04. Service is required.
C06	"Control head revision not compatible"	1 chirp every 2 seconds	(none)	Incompatible version of software was installed or <u>control unit</u> has failed. Service is required.
C07	"Control head revision lockout"	continuous (while button is held)	(none)	Once "Power Save" mode is activated, "attach" and "release" functions are prevented in connection with Code C06. Service is required.
E00 E01 E02 E03 E04	"EEPROM error, cell #"	occasional chirp	(none)	Memory error detected. Service is required.
I000	"I2C error (#)"	single chirp	(none)	Fault(s) detected in cable connecting to modular <u>circuit board</u> . If code does not clear automatically, service is required.
N00	"Automatic attach"	(none)	(none)	System activated "attach" mode as precaution because significant vacuum was detected, even though no one initiated "attach" function. No corrective action is necessary.
N01	"Automatic attach"	(none)	(none)	System activated "attach" mode as precaution because operator failed to release load completely. No corrective action is necessary.
N02	"Automatic attach"	(none)	(none)	System activated "attach" mode as precaution when lifter was powered up because power was previously lost while load was attached. No corrective action is necessary.
N03	"Unable to turn module power off"	1 chirp every 2 seconds	(none)	Modular <u>circuit board</u> failed to power down. Remove 9V battery. Disconnect connector between 12V <u>battery</u> and vacuum generating system. Charge battery completely (see 12-VOLT BATTERY RECHARGE to follow). Then reconnect battery and try to power down again. If code persists, disconnect connector. Service is required.
N04	"Failed to turn controls power off"	1 chirp every 2 seconds	(none)	<u>Control unit</u> failed to power down. Remove 9V battery. Disconnect connector between 12V <u>battery</u> and vacuum generating system. Charge battery completely (see 12-VOLT BATTERY RECHARGE to follow). Then reconnect battery and try to power down again. If code persists, disconnect connector. Service is required.
N05	"Unable to turn module power on"	1 chirp every 2 seconds	(none)	Modular <u>circuit board</u> failed to power up. Charge 12V <u>battery</u> (see 12-VOLT BATTERY RECHARGE to follow). Then power lifter up again. If code persists, service is required.

Code	On-Screen Message	Buzzer Pattern	Strobe Light Activity	Explanations/Directions
N06	"Power-down reminder"	2 chirps	on briefly	Power down to prevent 12V <u>battery</u> discharge when lifter is not in use.
N07	"Auto power-down disabled"	(none)	(none)	Automatic power-down is prevented. Power down lifter and power up again. If code persists, service is required.
N08	"Powering down in # seconds"	1 chirp per minute	(none)	Lifter will automatically power down in number of seconds shown. Press any button to cancel action.
N10	"App-support hardware fault"	(none)	(none)	Fault is detected in hardware that enables communication with mobile app. Power down lifter and power up again. If code persists, service is required.
U00	"WARNING! Is load attached?"	fast chirp	on	Attempt was made to power down lifter while load was still detected. Lower load onto stable support and release load <i>before</i> powering down lifter.
U01	"Also hold [Fn] to power down"	(none)	(none)	Hold " <u>function</u> " <u>button</u> and " <u>power</u> " <u>button</u> at same time to power down lifter.
U02	"Turn off? Let go of buttons"	(none)	(possible)	Use only " <u>function</u> " <u>button</u> and " <u>power</u> " <u>button</u> to power down lifter. Lifter cannot be powered down while any other button is pressed.
U03	"Timed release: # seconds"	1 chirp per button press	on	Timed release function is activated for number of seconds shown (see OPERATION: TO RELEASE THE PADS FROM THE LOAD). Press " <u>function</u> " <u>button</u> to cancel action or press " <u>attach</u> " <u>button</u> to override. No corrective action is necessary.
U04	"Also hold [Fn] to release"	(none)	(none)	Hold " <u>function</u> " <u>button</u> and " <u>release</u> " <u>button</u> at same time to release load.
U06	"Let go of [Fn] and Release"	(none)	on	Use only " <u>attach</u> " <u>button</u> to attach load. While " <u>attach</u> " <u>button</u> is pressed, lifter does not respond to pressing any other button. Release all buttons and press button(s) again to activate different function.
U08	"Menu not available in Attach"	(none)	(none)	Operator Menus cannot be accessed while lifter is attached to load.
U09	"Counterweight not retracted"	continuous	on	"Release" function is prevented because counterweight is not positioned correctly. Reposition counterweight as directed (see <i>OPERATING INSTRUCTIONS</i>).
U10	"Use POWER button for Live Stats"	(none)	(none)	"Power" <u>button</u> (not " <u>function</u> " <u>button</u>) is now used to access Live Stats. No corrective action is necessary.
U11	"Testing battery - wait to attach"	(none)	(none)	"Attach" function is prevented because <u>battery</u> test is currently in process. Wait until <u>vacuum pump</u> stops running and try again.
V000	"INSUFFICIENT VACUUM!"	continuous	on	Immediately lower load onto stable support until adequate vacuum can be obtained. Check load and <u>vacuum pads</u> for damage. Consult relevant ASSEMBLY, OPERATION and MAINTENANCE topics.
V001 V002 V003 V004	"INSUFFICIENT VACUUM #!" (# indicates relevant vacuum circuit)	continuous	on	Immediately lower load onto stable support until adequate vacuum can be obtained in vacuum circuit indicated. Check load and <u>vacuum pads</u> for damage. Consult relevant ASSEMBLY, OPERATION and MAINTENANCE topics. This Code can be activated in connection with Code N00.

Code	On-Screen Message	Buzzer Pattern	Strobe Light Activity	Explanations/Directions
V011 V012 V013 V014 V015	"Vacuum decrease on circuit #" (# indicates relevant vacuum circuit)	3 chirps	(none)	Vacuum decreased at a greater rate than expected in circuit(s) indicated. Possible causes include bouncing or landing load, as well as use on rough or porous loads and other sources of vacuum leaks. Consult relevant ASSEMBLY, OPERATION and MAINTENANCE topics to eliminate leaks when possible. When appropriate, you can also adjust sensitivity to vacuum level reductions (see INTELLI-GRIP® OPERATOR MENUS: TO CHANGE THE LEAK RATE THRESHOLD in SERVICE MANUAL).
V020	"Vacuum not increasing normally"	1 chirp every 2 seconds	on	Although lifter began to attach, vacuum level did not increase at normal rate. Make sure all <u>vacuum pads</u> seal securely (see OPERATION). This Code can be activated by use at high elevation. If so, contact WPG for directions.
V03A V03B	"Pump running excessively"	1 chirp every 2 seconds	(none)	<u>Vacuum pump</u> is running more often than normal. Likely causes include significant vacuum leak or difficulty achieving minimum vacuum level due to high elevation. In case of suspected leak, check for fault(s) in vacuum system (see relevant ASSEMBLY, OPERATION and MAINTENANCE topics). In case of high elevation, contact WPG for directions.
V040	"Lockout (vacuum sensor error)"	continuous	(none)	Once "Power Save" mode is activated, "attach" and "release" functions are prevented due to a <u>vacuum sensor</u> malfunction. Make sure sensor connectors are correctly plugged into <u>circuit board</u> .
V050	"DANGER! INSUFFICIENT VACUUM!"	continuous	on	Vacuum levels in BOTH circuits are insufficient for lifting. Keep everyone away from suspended load until it can be safely lowered to a stable support. Service is required.
V081 V082 V083 V084	"Sensor #_error (low)" (# indicates relevant vacuum circuit)	continuous in "attach" mode; 1 chirp every minute in "power save" mode	(none)	<u>Vacuum sensor</u> malfunction in vacuum circuit indicated. Make sure sensor connector is correctly plugged into <u>circuit board</u> .
V091 V092 V093 V094	"Sensor #_error (high)" (# indicates relevant vacuum circuit)	continuous in "attach" mode; 1 chirp every minute in "power save" mode	(none)	<u>Vacuum sensor</u> malfunction in vacuum circuit indicated. Make sure sensor connector is correctly plugged into <u>circuit board</u> .

INSPECTION SCHEDULE

Perform inspections according to the following frequency schedule.²¹ If any fault is found, correct it and perform the next most frequent inspection before using the vacuum lifter.

Action	Every Lift	Frequent ²² (20-40 hours)	Periodic ²³ (250-400 hours)
Examine <u>vacuum pads</u> for contaminates or damage.	✓	✓	✓
Examine load surface for contaminates or debris.	✓	✓	✓
Examine controls and indicators for damage.	✓	✓	✓
Check <u>battery</u> for adequate charge.	✓	✓	✓
Examine lifter's structure for damage.		✓	✓
Examine vacuum system for damage (including <u>vacuum pads</u> , fittings and hoses).		✓	✓
Examine <u>air filters</u> for conditions requiring service.		✓	✓
Perform VACUUM TEST.		✓	✓
Check for unusual vibrations or noises while operating lifter.		✓	✓
 If lifter has Remote Control System, perform REMOTE CONTROL SYSTEM TEST.		✓	✓
Examine the entire lifter for evidence of: <ul style="list-style-type: none"> • looseness, excessive wear, excessive corrosion • deformation, cracks, dents to structural or functional components • cuts in vacuum pads or hoses • any other hazardous conditions 			✓

²¹ Details about these inspections can be found in the following sections (eg, VACUUM PAD MAINTENANCE, 12-VOLT BATTERY ASSESSMENT, VACUUM TEST) or the *SERVICE MANUAL*.

²² The Frequent Inspection is also required whenever the lifter is out of service for 1 month or more.

²³ The Periodic Inspection is also required whenever the lifter is out of service for 1 year or more. Keep a written record of all Periodic Inspections. If necessary, return the lifter to Wood's Powr-Grip or an authorized dealer for repair (see LIMITED WARRANTY).

Action	Every Lift	Frequent²² (20-40 hours)	Periodic²³ (250-400 hours)
Inspect entire electrical system for damage, wear or contamination that could be hazardous, in compliance with all local codes and regulatory standards. <i>Caution: Use appropriate cleaning methods for each electrical part, as specified by codes and standards. Improper cleaning can damage parts.</i>			✓

Infrequent Use

If a lifter is used less than 1 day in a 2-week period, perform the Periodic Inspection *before each use*.

TESTING

Perform the following tests when you place the lifter in service *initially* and *following any repair*.²⁴ Correct any fault and retest before using the lifter.

Operational Tests

- Perform the VACUUM TEST to follow.
- Test all features and functions of the lifter (see OPERATING FEATURES, OPERATION and MAINTENANCE).

Load Test

Confirm the lifter can lift the Maximum Load Capacity:²⁵

- 1) Place a test load with appropriate LOAD CHARACTERISTICS (see INTENDED USE) in the upright position on a stable support.²⁶
- 2) Attach the vacuum pads to the load as previously directed.
- 3) After the vacuum pump stops running, hold the “function” button (Fn) and the “power” button (⏻) for at least 5 seconds to power down the lifter.²⁷



 **Take precautions in case load should fall during test.**

- 4) Raise the load a minimal distance, to make sure it is supported by the lifter for 5 minutes. The load must not slip or fall during this time. If it does, inspect each vacuum pad (see VACUUM PAD MAINTENANCE) and perform a VACUUM TEST. Correct any fault found and retest the lifter.
- 5) After the test has been completed, lower and release the load as previously directed.

12-VOLT BATTERY ASSESSMENT

While the lifter is powered up, a battery gauge on the LCD screen displays the current energy level.²⁸

Check the battery energy before every lift and after each day's use, to decide whether a charge is needed.²⁹

If battery energy is in the red range, discontinue lifter use and charge the battery (see next section). If battery energy continues to decrease, the lifter controls will become locked out until the battery is charged again.

Note: If the battery loses power, the notification buzzer sounds an alarm (see NOTIFICATION BUZZER BATTERY TEST to follow).

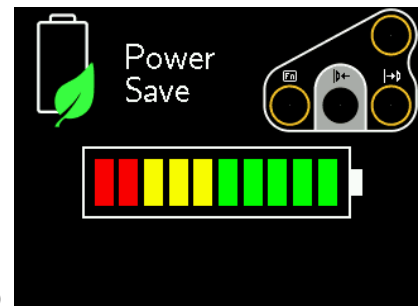

²⁴ Details about these tests can be found in the following sections (eg, 12-VOLT BATTERY ASSESSMENT, VACUUM TEST) or the *SERVICE MANUAL*.

²⁵ An equivalent simulation may also be used. Contact Wood's Powr-Grip for more information.

²⁶ Flat Lifters are exempt from this requirement.

²⁷ During this time the LCD screen displays "WARNING! Is load attached?", the notification buzzer chirps rapidly and the strobe light flashes.

²⁸ If the lifter remains in "power save" mode for a long time, the pump will run periodically to test the battery.

²⁹ If the battery charger is connected to an AC power source, the reading on the battery gauge will not be accurate.

12-VOLT BATTERY RECHARGE³⁰

Charge the battery whenever the battery gauge shows reduced energy (see previous section).³¹

Caution: Make sure the lifter is powered down.

 **Make sure power source has ground fault circuit interrupter.**

Identify the input voltage marked on the battery charger and plug it in to an appropriate power source.³²

Press the "MODE" button to select "NORMAL" mode. Lights 1-4 indicate the charging level attained.³³ When the battery is fully charged, light 4 (green) turns on and the charger switches to maintenance mode.

The battery should take no more than 8 hours to charge completely.³⁴ After reaching level 3, the charger analyzes the battery condition. If the battery needs to be replaced, the charger's red error light (!) turns on (see REPLACEMENT PARTS).

Before you return the lifter to service, recheck the battery as previously directed.

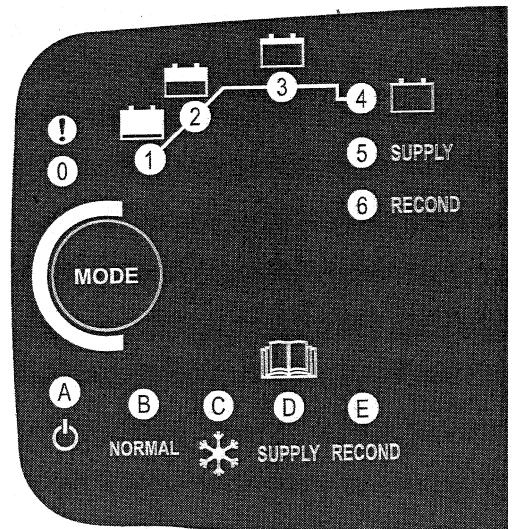

NOTIFICATION BUZZER BATTERY TEST

The lifter automatically tests the 9-volt battery for the notification buzzer each time during power-up. If this battery wears out, the LCD screen displays "Replace 9V battery?" and the buzzer chirps once per minute. Replace the battery as follows:

- 1) Power down the lifter.
- 2) Release the buzzer battery holder by pressing inward.
- 3) Slide the battery tray out, as shown.
- 4) Install a new 9-volt battery according to the polarity markings.
- 5) Slide the battery tray back into position.
- 6) Power up the lifter again, to test the replacement battery.



³⁰ You may use a battery charger other than the one supplied, provided that it is designed for 12-volt DC, AGM type, lead-acid batteries. If so, disconnect the battery from the vacuum generating system before charging.

³¹ To maximize the battery's lifespan, charge it promptly after each use.

³² Any external power supply must conform to all applicable local codes. **Caution: Do not operate the lifter while the charger is connected to an AC power source.**

³³ If none of the charging level lights turns on, the battery connection or the battery itself may be faulty. If the red error light (!) turns on immediately, the battery leads may be reversed or the charger terminals may be short-circuited; once the problem has been corrected, the charger should function normally. The red error light can indicate other problems, depending on the mode selected and level of charging; if necessary, contact Wood's Powr-Grip for assistance.

³⁴ The charger is designed to automatically sense the energy level of the battery and reduce the charging rate when the battery is fully charged. Accordingly, the charger does not need to be unplugged until the lifter is going to be used again.

VACUUM PAD MAINTENANCE

Pad-to-Load Friction Coefficient

 The friction coefficient represents the lifter's ability to resist load slippage.³⁵ The Maximum Load Capacity assumes a friction coefficient of 1, based on testing of clean, new, standard rubber vacuum pads on clean, dry, regular glass. ***If the lifter is used under other conditions, a qualified person must first determine the effective lifting capacity.***³⁶

Long-term exposure to heat, chemicals or UV light can reduce the friction coefficient of vacuum pads. Replace vacuum pads, along with replaceable inserts or sealing rings, every 2 years or more often, when necessary.

Pad Inspection

Inspect each vacuum pad according to the preceding INSPECTION SCHEDULE and TESTING, and correct the following faults before using the lifter (see REPLACEMENT PARTS when applicable):

- Contaminates on the face (1) or sealing edges (2) (see below).
- Filter screen (3) missing from face.
- Nicks, cuts or abrasions in sealing edges.

 ***Replace any pad insert or sealing ring that has damaged sealing edges.***³⁷

- Wear, stiffness or glaze.

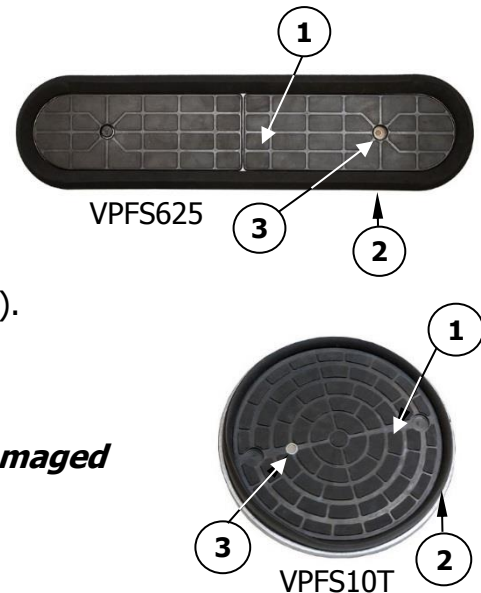

Pad Cleaning

- 1) Regularly clean the face of each vacuum pad, using soapy water or other mild cleansers to remove oil, dust and other contaminants.

 ***Never use harsh chemicals on vacuum pad.***

Solvents, petroleum-based products (including kerosene, gasoline and diesel fuel) or any harsh chemicals can damage vacuum pads.

 ***Never use rubber conditioners on vacuum pad.***

Many rubber conditioners can leave a hazardous film on vacuum pads.

- 2) Prevent liquid from entering the vacuum system through the suction hole on the pad face.
- 3) Wipe the pad face clean, using a clean sponge or lint-free cloth to apply the cleanser.³⁸
- 4) Allow the pad to dry completely before using the lifter.



³⁵ Flat Lifters are exempt from this requirement.

³⁶ If necessary, contact Wood's Powr-Grip for help in conducting a friction test.

³⁷ See TO REPLACE PAD INSERTS IN VPFS625 PADS or TO REPLACE SEALING RINGS IN VPFS10T PADS to follow.

³⁸ A brush with bristles *that do not harm rubber* can help remove contaminants clinging to sealing edges. If these cleaning methods are not successful, contact Wood's Powr-Grip or an authorized dealer for assistance.

VACUUM TEST

Test the vacuum system for leakage according to the preceding INSPECTION SCHEDULE and TESTING.

- 1) Clean the face of each vacuum pad as previously directed.
- 2) Use a test load with weight equal to the Maximum Load Capacity, a clean, smooth, nonporous surface and other appropriate LOAD CHARACTERISTICS (see INTENDED USE).³⁹ 
- 3) Attach the lifter to the test load as previously directed. After the vacuum pump stops running, the vacuum level should appear in the green range on each of the vacuum gauges.
- 4) Raise the load a minimal distance, to make sure the vacuum pads are loaded to capacity. Then hold the "function" button (**Fn**) and the "power" button (**⏻**) for at least 5 seconds to power down the lifter.⁴⁰



Take precautions in case load should fall during test.

- 5) Watch the vacuum gauges: *The vacuum level should not decrease by more than 4" Hg [-14 kPa] in 5 minutes.* Lower the load after 5 minutes or whenever a lifter fails the test.



Never use a lifter that has failed VACUUM TEST.

- 6) Correct any deficiency in the vacuum system before using the lifter.

REMOTE CONTROL SYSTEM TEST



If the lifter has a Remote Control System, test it where the lifter is normally used. Use the radio transmitter to activate each of the remote functions.⁴¹ Vary the transmitter's direction and distance from the lifter, to make sure transmissions are effective.⁴²

If the Remote Control System is not functioning correctly, ...

- the battery for the radio transmitter may need to be replaced;
- metal or other electrically conductive surfaces may be causing radio interference. Reposition the transmitter to transmit signals effectively.

If the problem persists, vary the test conditions, to determine whether there is transmission interference in the work environment or the Remote Control System is not functioning. Correct any fault before using the Remote Control System.

³⁹ The load should have either a flat surface or no more curvature than the lifter is designed for (if any).

⁴⁰ During this time the LCD screen displays "WARNING! Is load attached?", the notification buzzer chirps rapidly and the strobe light flashes.

⁴¹ Use a test material with appropriate LOAD CHARACTERISTICS (see INTENDED USE) to test the "attach" and "release" functions.

⁴² This may require assistance from someone near the lifter, to verify functions are working as intended.

TO REPLACE SEALING RING IN VPFS10T PADS

If the lifter has VPFS10T vacuum pads, replace sealing rings as follows:

- 1) Remove the old sealing ring.
Make sure the entire vacuum pad is clean, including the mounting groove.
- 2) Place the inside edge of a new sealing ring against the inside edge of the mounting groove.
- 3) Push the sealing ring into the mounting groove, beginning in 4 locations.
- 4) Push gently and firmly on the outside edge of the sealing ring until the flat side fits flush against the bottom of the mounting groove. A pad ring installation tool helps (see REPLACEMENT PARTS).
- 5) Make sure the sealing ring seats securely in the mounting groove, all the way around the vacuum pad.

Note: If any part of the sealing ring comes out of the mounting groove, inspect the sealing ring for damage and reinstall an undamaged sealing ring.

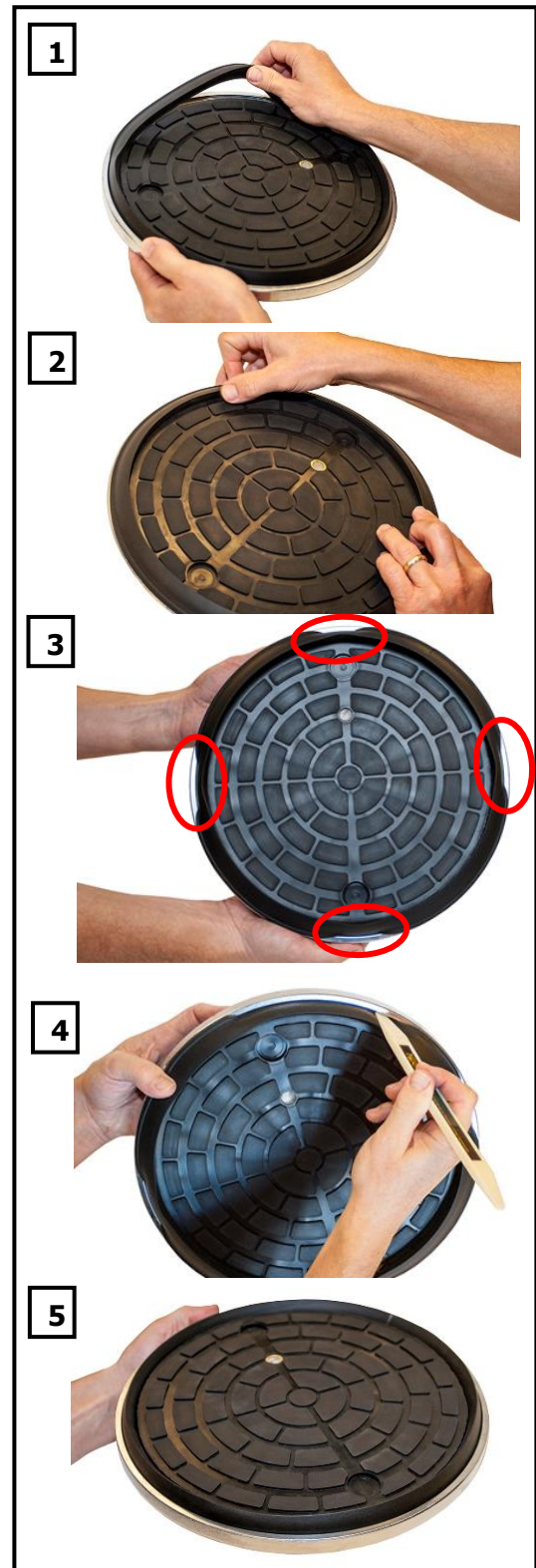

To REPLACE PAD INSERTS IN VPFS625 PADS

If the lifter has VPFS625 vacuum pads, replace pad inserts as follows:

1) Remove the lock nuts and washers that secure the top plate to the face plate of the pad assembly.

2) Remove the top plate.

3) Remove the old pad insert.

Note: Save the filter screen (circled).

4) Install the new pad insert. Make sure the hole for the filter screen is positioned correctly.

Note: The new insert will compress to take on the form of the old one.

5) Match the holes in the top plate with the holes in the face plate. Make sure to place the air-line connector (circled) over the filter screen hole (circled).

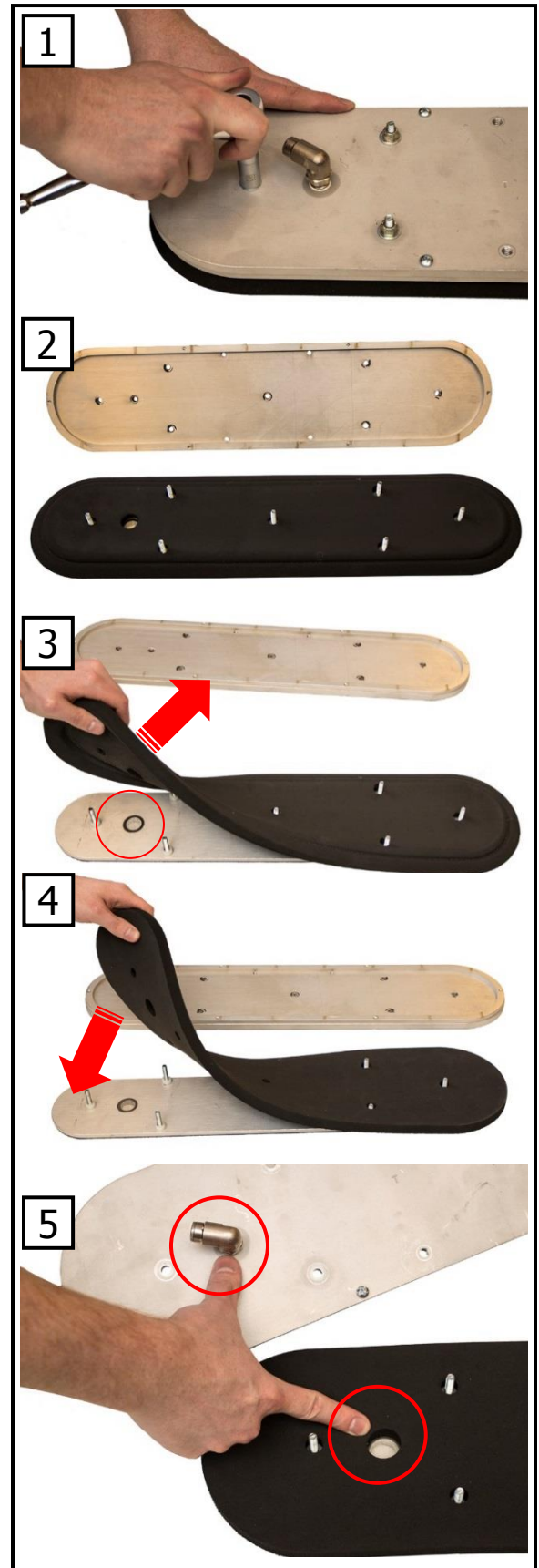

6) Reinstall the top plate, washers and lock nuts.

7) Tighten all lock nuts securely.
Note: Replace worn nuts as needed.

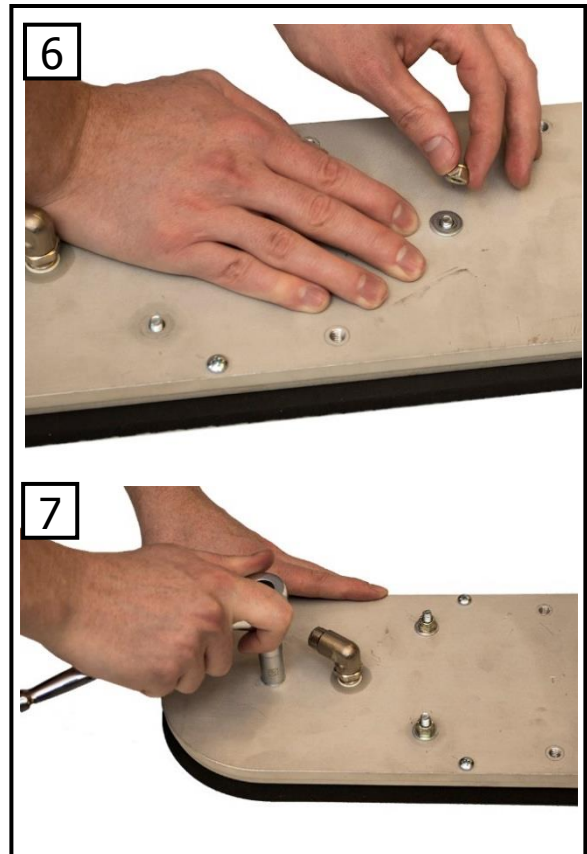

REPLACEMENT PARTS LIST

Stock No.	Description	Qty.
97465HV	Pad Frame T-Arm Assembly w/VPFS10T Vacuum Pads (optional)	2
97465	Pad Frame T-Arm Assembly w/VPFS625 Vacuum Pads (optional)	2
97464	Pad Frame Extension Kit for Roof Panels (optional)	1
97463	Pad Frame Rocker Arms Set for Roof Panels (optional)	1
65442CC	Vacuum Hose – 0.160" ID x 1/4" OD x 8" Length – Coiled – Red	4
65442CA	Vacuum Hose – 0.160" ID x 1/4" OD – Red	*
65442AM	Vacuum Hose - 0.245" ID x 3/8" OD x 48" Length - Coiled - Green	2
65441	Vacuum Hose - 0.245" ID x 3/8" OD x 48" Length - Coiled - Red	2
65440	Vacuum Hose – 0.245" ID x 3/8" OD – Red	*
65439BM	Vacuum Hose – 3/32" ID x 5/32" OD – Green	*
65439AM	Vacuum Hose – 3/32" ID x 5/32" OD – Red	*
65437	Vacuum Hose – 0.245" ID x 3/8" OD – Green	*
65429BM	Vacuum Hose – 0.160" ID x 1/4" OD – Green	*
65429BK	Vacuum Hose – 0.160" ID x 1/4" OD x 8" Length – Coiled – Green	4
65025	Pad Spring – Tapered Type (for VPFS625 pads)	16
65010	Pad Spring – Coil Type (for VPFS10T pads)	4
64713AU	Battery Charger – 7 Amp – 220 / 240 V AC – Australian Type (optional)	1
64712US	Battery Charger – 7 Amp – 100 / 115 V AC	1
64711EU	Battery Charger – 7 Amp – 220 / 240 V AC (optional)	1
64665	Battery – 12 V DC – 18 Amp-Hours	1
59906	Remote Control System Retrofit Kit (optional)	1
59086NC	Battery Connector – Twin Lead	1
58383	Vacuum Pad – Model VPFS625 / 6" x 25" [15 cm x 64 cm]	4
54107	Movable Pad Mount – 2" Tubing Size (for VPFS10T pads)	4
54384NC	Power Lead	1
53124	Pad Fitting – Elbow – 5/32" ID – Long Stem (for VPFS10T pads)	4
49726	Vacuum Pad Insert – Model VIFS625 / 6" x 25" [15 cm x 64 cm] (for VPFS625 pads)	4
49724TT	Sealing Ring Insert – Model VIFS10T2 – Closed Cell Foam (for VPFS10T pads)	4
49724RT	Sealing Ring Insert – Model VIFS10T3 – Heat-Resistant Rubber (for VPFS10T pads)	4
49672FT	Vacuum Pad – Model VPFS10T / 10" [25 cm] Diameter – w/Replaceable Sealing Ring	4
49150	End Plug – 2-1/2" x 2-1/2" x 1/4" Tubing Size	3
49122	End Plug – 2" x 2" x 1/4" Tubing Size	4
36105	Service Manual – 12 V DC – Dual Vacuum System – Intelli-Grip®	1
29353	Pad Cover (for VPFS10T pads)	4
20050	Pad Ring Installation Tool (for VPFS10T pads)	1
93022	Quick Connector – 1/8 FNPT – Male End – w/45° Barb	4
57348AM	Quick Connector – 1/8 FNPT – Female End – w/Fittings	8
15310AM	Pad Fitting – Push-In Swivel Elbow – 1/4 MNPT to 3/8" OD Hose Size (for VPFS625 pads)	4
13530	Cotterless Hitch Pin – 1/2" x 3 1/2"	6
11712	Clamp Collar – 1.25-12 Thread – 1-Piece	1
10906PM	Shoulder Bolt – Socket Head – 3/8" x 1" x 5/16-18 Thread (for mounting VPFS625 pads)	16
10900	Shoulder Bolt – Socket Head – 5/16" x 1/2" x 1/4-20 Thread (for mounting VPFS10T pads)	24

* Length as required; vacuum hose is sold by the foot (approx. 30.5 cm).

See **SERVICE MANUAL #36105** for additional parts.

**SERVICE ONLY WITH IDENTICAL REPLACEMENT PARTS,
AVAILABLE AT WPG.COM OR THROUGH AN AUTHORIZED WPG DEALER**

LIMITED WARRANTY

Wood's Powr-Grip® (WPG) products are carefully constructed, thoroughly inspected at various stages of production, and individually tested. They are warranted to be free from defects in workmanship and materials for a period of one year from the date of purchase.

If a problem develops during the warranty period, follow the instructions hereafter to obtain warranty service. If inspection shows the problem is due to defective workmanship or materials, WPG will repair the product without charge.

WARRANTY DOES NOT APPLY WHEN:

- modifications have been made to the product after leaving the factory;
- rubber portions have been cut or scratched during use;
- repairs are required due to abnormal wear and tear; and/or
- the product has been damaged, misused, or neglected.

If a problem is not covered under warranty, WPG will notify the customer of costs prior to repair. If the customer agrees to pay all repair costs and to receive the repaired product on a C.O.D. basis, WPG then will proceed with repairs.

TO OBTAIN REPAIRS OR WARRANTY SERVICE

For purchases in *North America*:

Contact the Technical Service Department at Wood's Powr-Grip. When factory service is required, ship the complete product – prepaid – along with your name, address and phone number to the street address hereafter.

For purchases in *all other localities*:

Contact your dealer or the Technical Service Department at Wood's Powr-Grip for assistance.

Wood's Powr-Grip Co., Inc.
908 West Main St
Laurel, MT USA 59044

406-628-8231 (phone)
800-548-7341 (phone)
406-628-8354 (fax)

TYPE: STANDARD	FILE DIRECTORY: FILE (SHEET): 713K-W01 [K-W01]
WIRE LEGEND: CONTROLLED BY WIRING SYMBOLS DRAWING EXCEPT AS NOTED AND BELOW. LINE STYLES AND WIDTHS FOR WIRE UNLESS NOTED OTHERWISE. N/A 22 AWG N/A 18 AWG N/A N/A N/A N/A	
PRODUCT MANAGER: GARY B.	DATE: 12/01/2017
CHECKED: <i>CR</i>	02-26-18
APPROVED: <i>Chen</i>	2-27-18
THIS DRAWING IS THE PROPERTY OF WOOD'S POWR-GRIP CO., INC. , LAUREL, MONTANA U.S.A. IT IS LOANED WITH THE UNDERSTANDING THAT NEITHER IT NOR ANY INFORMATION CONTAINED THEREIN WILL BE COPIED, PUBLISHED OR TRANSMITTED TO OTHERS WITHOUT EXPRESS WRITTEN PERMISSION.	
RADIO REMOTE CONTROL MRT4-DC3 RADIO RECEIVER WIRING SCHEMATIC, FCC & CE D713K-W01 [K-W01]	
SIZE: SCALE: A NONE	REVISION: ECN NUMBER: ECN DATE: ECN BY: EST. WEIGHT: 02.A 4541 02/21/2018 CCH N/A

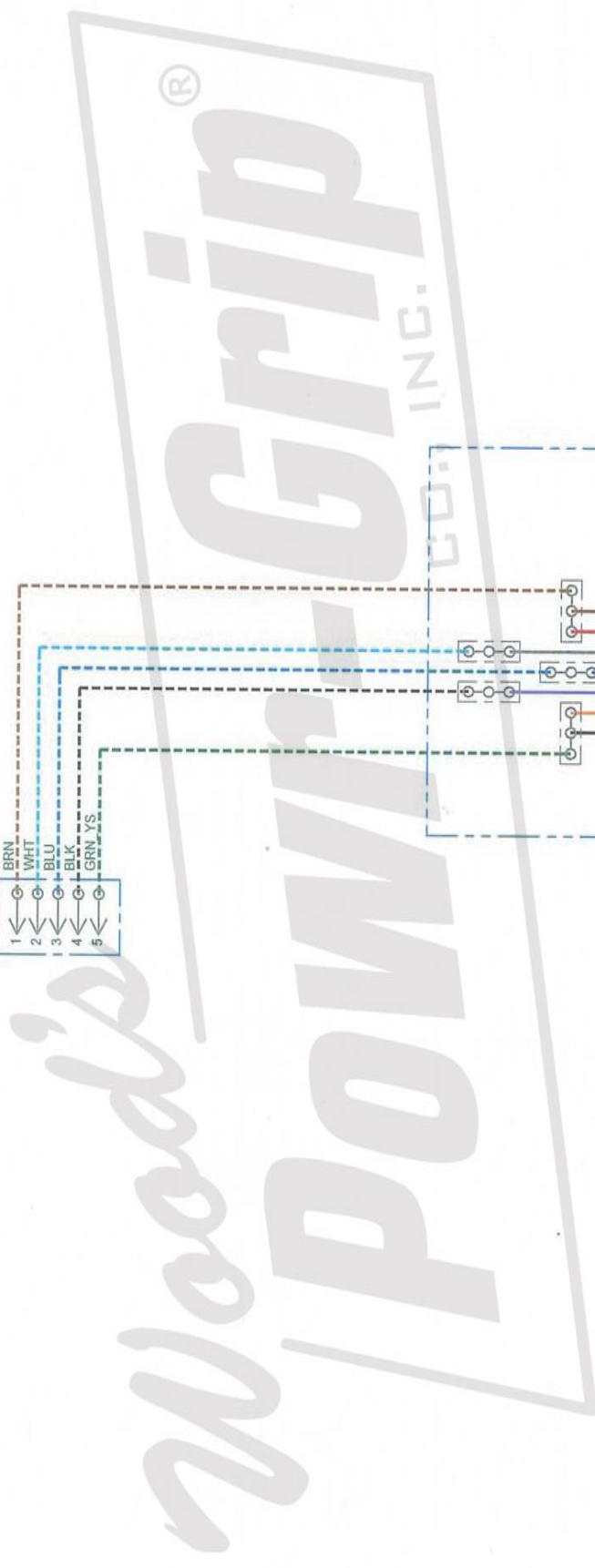
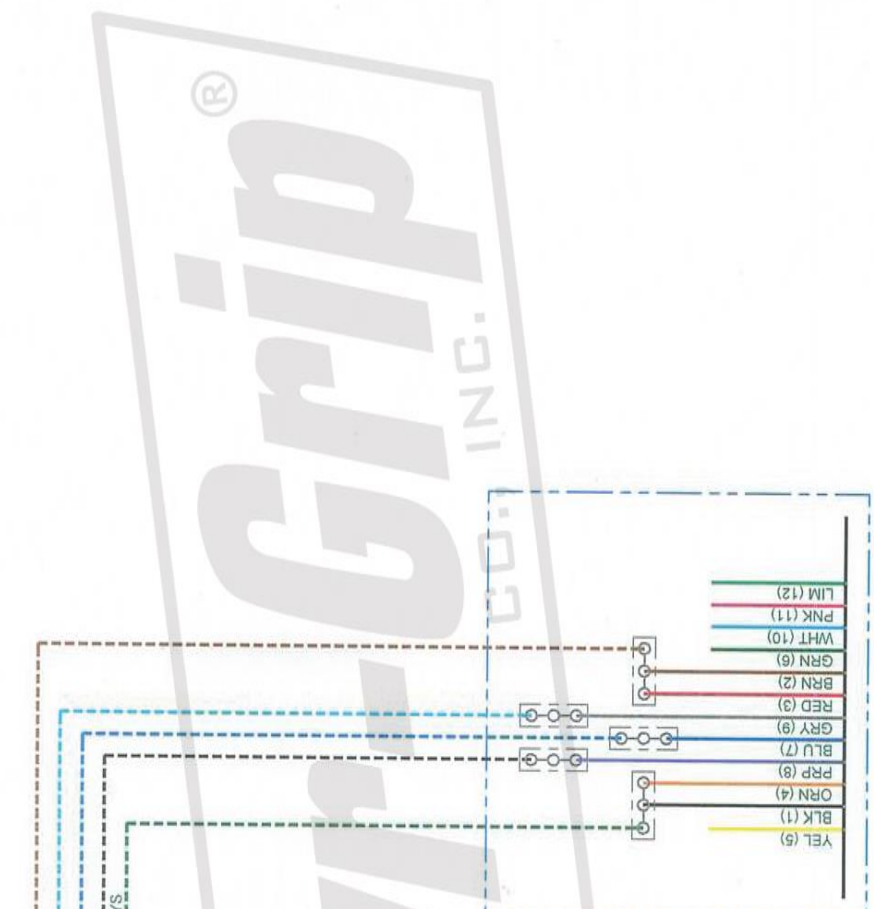
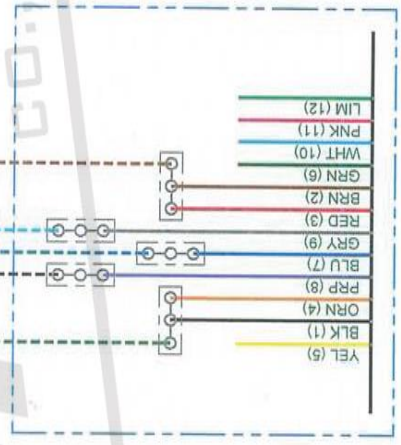
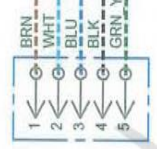

WIRE LEGEND: CONTROLLED BY WIRING SYMBOLS DRAWING EXCEPT AS NOTED AND BELOW. LINE STYLES AND WIDTHS FOR WIRE UNLESS NOTED OTHERWISE: --- 18 AWG - - - 16 AWG ----- N/A ----- N/A		TYPE: STANDARD	FILE DIRECTORY: 714 FILE (SHEET): 714-W01 [W01]
PRODUCT MANAGER: NATHAN G. DATE: 10/21/2009		3 SCFM DC POWER UNIT	
CHECKED: <i>CP</i>	DATE: 01-19-15	BATTERY CHARGER WIRING DIAGRAM	
APPROVED: <i>Chen</i>	DATE: 2-16-15	SIZE: SCALE: A NONE	REVISION: ECN NUMBER: 01.A 3623
		ECN DATE: 01/07/2015	EST. WEIGHT: 0 LBS

