



TYPHOON INTAKE SYSTEMS



INSTALLATION INSTRUCTIONS

69-9504

VOLKSWAGEN / AUDI

2009-10 Passat, GLi

2009-12 CC, GTi, EOS

2008-12 A3

L4-2.0L Turbo

TOOLS NEEDED:

- Ratchet
- Extension
- 10mm socket
- T25 Torx
- Phillips screw driver
- Flat blade screw driver
- Knife
- Pliers
- 10mm wrench
- 4mm allen
- 3mm allen
- 8mm allen

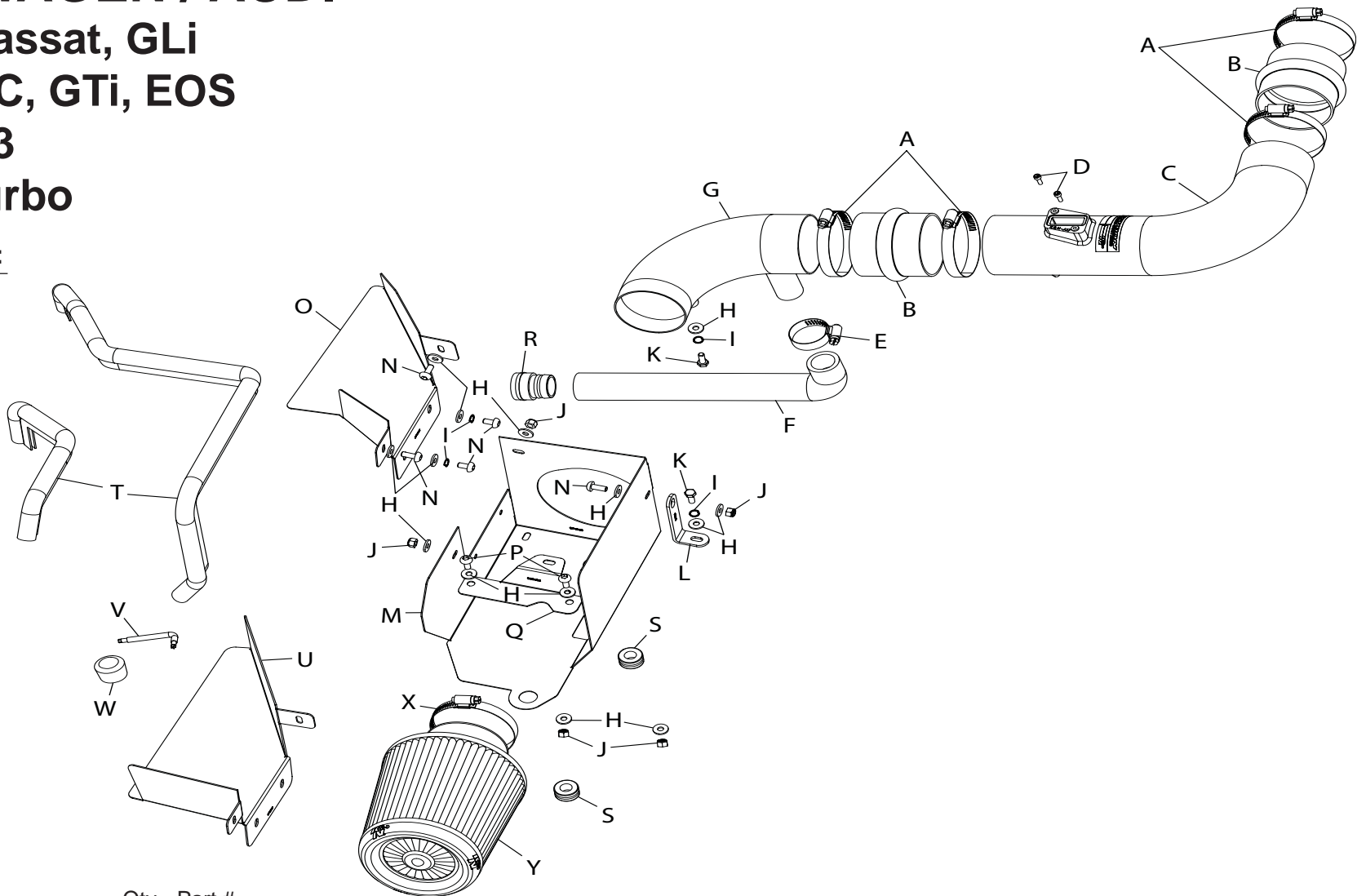

PARTS LIST:

Description	Qty.	Part #	Description	Qty.	Part #	Description	Qty.	Part #
A Hose Clamp #44 Stainless	4	08560	J Nut; 6mm Nylock, Hexhead	5	07512	S Grommet; 1"OD, 1/2"ID, 1/2"thk	2	08064
B Hose; 3" ID X 3" L Hump	2	08696	K Bolt; 6mm-1.00X16mm,	2	07812	T Edge Trim (61")	1	102492
C Intake Tube	1	27469	L Bracket; "L" STL, TK/PC	1	010051	U Heat Shield; Scoop B,	1	074063
D Bolt; M4-0.07 8mm, A/H Cap	2	07733	M Heat Shield	1	074060	V Wrench; Torx T20 T/R, L-Key	1	69801
E Hose Clamp #20	1	08436	N Bolt; M6x1.00x16mm, Bttnhd	5	07730	W Cap Plug; 15/16" ID, 3/4" L,	1	08246
F Hose; 1" id X 11" L W/ 1" L 90°	1	08479	O Heat Shield; Scoop A,	1	074062	X Hose Clamp #48	1	08601
G Intake Tube	1	27468	P Bolt; M6X1.00" 12mm Bttnhd	2	07794	Y Air Filter	1	RX-4730XD
H Washer; 1/4" id X 5/8" od-sae	14	08275	Q Bracket; "Z", Mild STL, TK/PC	1	083132			
I Washer; 1/4" Lock, ZN	4	08198	R Adaptor; 1-1/8" OD	1	088012			

NOTE: FAILURE TO FOLLOW INSTALLATION INSTRUCTIONS AND NOT USING THE PROVIDED HARDWARE MAY DAMAGE THE INTAKE TUBE, THROTTLE BODY AND ENGINE.

TO START:

1. Turn off the ignition and disconnect the negative battery cable.

NOTE: Disconnecting the negative battery cable erases pre-programmed electronic memories. Write down all memory settings before disconnecting the negative battery cable. Some radios will require an anti-theft code to be entered after the battery is reconnected. The anti-theft code is typically supplied with your owner's manual. In the event your vehicles' anti-theft code cannot be recovered, contact an authorized dealership to obtain your vehicles anti-theft code.



2. Disconnect the mass air sensor electrical connection.



3. On vehicles equipped with an air injection system, release the air injection hose coupler from the upper air box half.



4. Loosen the eight screws securing the upper air box to the lower air box.



5. Release the spring clamp securing the factory intake hose to the factory intake tube and then unhook the intake hose.



6. Remove the upper air box assembly from the vehicle as shown.



7. Release the three retaining clips securing fresh air intake lid and then remove the lid from the vehicle.



8. Disengage the fresh air intake duct from the lower air box and then remove the duct from the vehicle.



9. Loosen the bolt securing the lower air box to the vehicle.



10. Lift the air box up to dislodge it from the mounting grommets and then remove it from the vehicle. **NOTE: K&N Engineering, Inc., recommends that customers do not discard factory air intake.**



11. Remove the two screws which secure the fresh air inlet duct to the core support and then remove the duct from the vehicle.

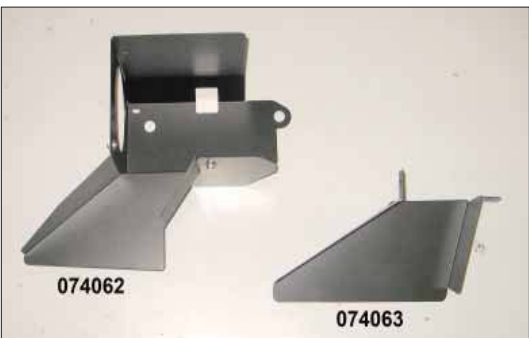

12. Install the appropriate fresh air scoop (074062 or 074063) for your vehicle onto the heat shield using the provided hardware. #074062 will fit VW models GLI and GTI and Audi models A3, 074063 will fit VW models Passat, CC, & EOS

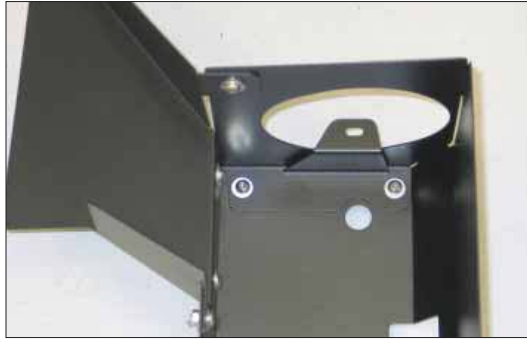

13. Install the tube mounting bracket onto the heat shield and secure it with the provided hardware.

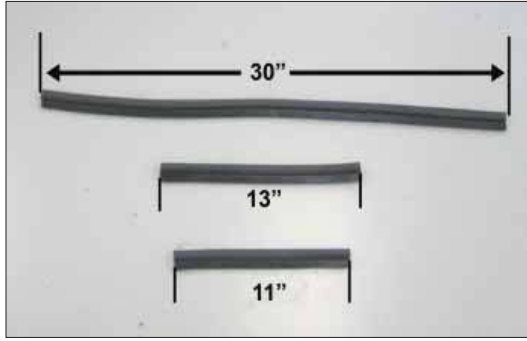

14. Cut the provided edge trim into three sections as shown. One section should be 30", one section should be 13" and the last section should be 11" long.



15. Install the 30" length of edge trim onto the heat shield assembly as shown.



16. Install the 11" length of edge trim onto the heat shield assembly as shown.



17. Install the 13" length of edge trim into the hole of the heat shield as shown.



18. Install the two grommets into the base of the heat shield as shown.



19. Install the heat shield mounting bracket (010051) onto the heat shield using the provided hardware.



20. Set the heat shield into position on the air box mounting studs as shown and secure the mounting bracket with the provided hardware.



21. Install the provided silicone hump hose (08696) onto the factory intake tube and secure with the provided hose clamp.



22. Remove the screws securing the mass air sensor and then remove the mass air sensor from the factory air box.



23. Install the mass air sensor into the K&N secondary intake tube and secure with the provided hardware.



24. Install the K&N secondary intake tube into the silicone hose at the factory intake tube and secure with the provided hose clamp.

NOTE: Do not completely tighten at this time.

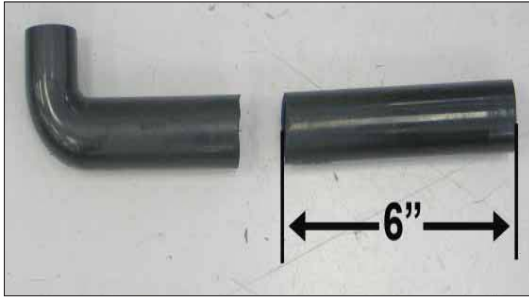

25. On vehicles equipped with an air injection system, cut 6" off of the provided air injection hose as shown.



26. On vehicles equipped with an air injection system, install the provided coupler into the cut piece of air injection hose.



27. Install the air injection hose assembly onto the K&N primary intake tube as shown and secure with the provided hose clamp. On vehicles not equipped with air injection, install the provided cap plug onto tube and secure with the provided hose clamp.



28. Install the provided silicone hump hose (08696) onto the K&N primary intake tube and then install the primary intake tube into the heat shield. Secure the intake tube with the hose clamps and hardware provided to the mounting bracket and then connect the air injection hose to the factory air injection hose if equipped.



29. Install the K&N air filter onto the primary intake tube, adjust the filter for adequate clearance and then tighten all of the hose clamps and tube mounting bracket.



30. Reconnect the mass air sensor electrical connection.



31. Reconnect the vehicle's negative battery cable. Double check to make sure everything is tight and properly positioned before starting the vehicle.

32. It will be necessary for all K&N® high flow intake systems to be checked periodically for realignment, clearance and tightening of all connections. Failure to follow the above instructions or proper maintenance may void warranty.

ROAD TESTING:

1. Start the engine with the transmission in neutral or park, and the parking brake engaged. Listen for air leaks or odd noises. For air leaks secure hoses and connections. For odd noises, find cause and repair before proceeding. This kit will function identically to the factory system except for being louder and much more responsive.
2. Test drive the vehicle. Listen for odd noises or rattles and fix as necessary.
3. If road test is fine, you can now enjoy the added power and performance from your kit.
4. K&N Engineering, Inc., suggests checking the air filter element periodically for excessive dirt build-up. When the element becomes covered in dirt (or once a year), service it according to the instructions on the Recharger® service kit, part number 99-5050 or 99-5000

STREET LEGAL IN MOST STATES

**NOT LEGAL FOR USE IN CA & OTHER STATES
ADOPTING CA EMISSIONS STANDARDS**

See our catalog or knfilters.com for CARB status on each part for a specific vehicle

* FREE K&N® decal To register your warranty, please see us online at knfilters.com/register. FREE K&N® decal *

• 1455 CITRUS ST., P.O. BOX 1329, RIVERSIDE, CA., U.S.A. 92502 • TECH SERVICE 800-858-3333 • FAX 951-826-4001
• e-mail: tech@knfilters.com • WWW: <http://www.knfilters.com>

19019c
12/12/11