



Ultrasonics.Steam.Ultraclean.

## Operating manual



**Elmasolvex® VA**

**Watches / small parts cleaning machine**

• English •

## Contents

1	General.....	5
2	Important safety instructions.....	5
2.1	Notes for using this manual.....	5
2.1.1	Information signs / symbols in the manual / on the cleaning machine.....	5
2.1.2	Signal words in this manual .....	6
2.2	Safety instructions for use of the cleaning machine..	6
3	Product description.....	9
3.1	How it Works.....	9
3.2	Product Features .....	10
3.3	Scope of delivery .....	11
3.4	Optional accessories.....	11
3.5	CE conformity .....	12
3.6	Technical Data.....	13
3.7	Cleaning machine front side description.....	14
3.8	Cleaning machine rear side description .....	15
3.9	Control panel description .....	16
3.10	Handling of the control panel .....	17
3.11	Description of the menu icons.....	18
3.12	Cleaning chamber description.....	19
3.13	Media tanks description .....	20
3.13.1	Suction filter functionality .....	20
4	Before the initial commissioning .....	21
4.1	Unpacking and installing the cleaning machine.....	21
4.2	Attaching protective grilles .....	22
4.3	Connecting activated carbon unit or exhaust air tubes .....	23
4.4	Filling media tank.....	25
4.4.1	Checking shut-off valves of the quick couplings...28	
5	Initial commissioning .....	30
5.1	Connecting cleaning machine to mains power supply .....	30
5.2	Switching on cleaning machine.....	30
5.3	Selecting language in the display.....	30
6	Daily cleaning operation .....	31
6.1	Checking filling levels of the media tanks.....	31
6.2	Loading and inserting basket holder .....	32
6.3	Selecting and starting cleaning program .....	35
6.3.1	Special Programs .....	39
6.4	Interrupting / aborting cleaning program.....	40

7	Settings .....	42
7.1	Cleaning machine Settings .....	42
7.1.1	Date / Time .....	43
7.1.2	Administrator PIN.....	44
7.1.3	Event List.....	46
7.1.4	Changing user language.....	48
7.1.5	Visible cleaning programs.....	49
7.1.6	Reminders .....	50
7.1.7	Display Operating Hours.....	55
7.1.8	Setting signal tone for program end .....	57
7.2	Creating your own cleaning programs.....	58
7.2.1	Create new cleaning program.....	59
7.2.2	Create cleaning program from copy .....	62
7.2.3	Modifying existing cleaning program.....	63
7.2.4	Delete cleaning program.....	64
8	Media (cleaning / rinsing solutions) .....	65
8.1	Recommended media .....	66
8.2	Technical limitations.....	67
8.3	Limitations for solvent-based media .....	67
8.3.1	Flammable, solvent-based media .....	67
8.3.2	Non-flammable, solvent-based media.....	67
8.3.3	Environmental hazard from solvent-based media .....	68
9	Care and maintenance tasks.....	69
9.1	Daily maintenance actions .....	69
9.1.1	Filling level check of the media tanks.....	69
9.1.2	Cleaning the cleaning chamber.....	70
9.1.3	Cleaning of the drain sieve .....	71
9.1.4	Cleaning the filling level sensors.....	71
9.1.5	Leak checks.....	71
9.2	Continuous maintenance actions .....	72
9.2.1	Change of cleaning and rinsing media .....	72
9.2.2	Inspect media tanks, covers, suction filters.....	73
9.2.3	Basket holder.....	75
10	Maintenance actions / service intervals .....	77
10.1	2-5 years service interval by user.....	77
10.1.1	Replace seal for cleaning chamber cover .....	78
10.2	5 years service interval by Service staff .....	79
10.2.1	Prescribed parts to be replaced (mandatory) .....	79
10.2.2	Recommended parts to be replaced .....	80
10.3	Service intervals according to display message .....	82
10.3.1	Replace seal of the basket rotation unit .....	82
10.4	Extended safety test .....	83

---

11	Operating faults .....	85
11.1	Fault messages on the display.....	85
11.2	Cleaning machine faults without indication on the display.....	100
11.3	Fault clearance by user.....	100
11.3.1	Cleaning deflagration protection .....	101
11.3.2	Manual venting of the cleaning chamber.....	103
11.4	Repairs .....	104
11.5	Shipment of the machine .....	104
12	Decommissioning and disposal.....	105
13	Manufacturer address / contact address .....	105
14	Appendix 1: Activated carbon unit .....	106
14.1	Description.....	106
14.2	Filling / Installation / Commissioning .....	108
14.3	Maintenance .....	110
14.3.1	Emptying condensate separator .....	110
14.3.2	Replacing activated carbon granulate .....	110
14.3.3	Changing PE filter.....	111
15	Appendix 2: Pager .....	113
16	Appendix 3: Procedure and parameter recommendations using Expert Mode .....	115
16.1	Cleaning parameters recommendations in Expert Mode .....	119
16.2	Rinsing parameters recommendations in Expert Mode .....	120
16.3	Drying parameters recommendations in Expert Mode .....	121
16.3.1	Spinning .....	121
17	Appendix 4: Expert Mode .....	128
17.1	Elmasolvex VA Expert Mode.....	128
17.2	Creating your own cleaning programs.....	129
17.3	Creating a new cleaning program .....	130
17.4	Creating a cleaning program from a copy .....	133
17.5	Modifying an existing cleaning program .....	134
17.6	Deleting a cleaning program .....	135

# 1 General

The present Operating Instructions are part of the delivered equipment. They must be ready for use at any time and remain with the cleaning machine in case of resale. We reserve the right to carry out technical modifications on the cleaning machine due to advanced development. An operating manual cannot take account of every conceivable use. An operating manual cannot take account of every possible use. Contact your dealer or the manufacturer for further information or in the event of problems which are not covered or not sufficiently covered in this operating manual.

## 2 Important safety instructions

### Strictly observe the following before start-up

Read through this manual carefully before use and only use this cleaning machine in accordance with the instructions included here. In addition to the instructions in this operating manual, also observe the country-specific safety regulations.

### Exclusion of liability

The manufacturer shall not accept any liability in the event of injuries to persons, damage to the cleaning machine or product to be cleaned which has been caused by improper use contrary to the instructions in this operating manual and non-observance of the maintenance intervals.

The owner shall be responsible for the instruction of the operating personnel.

### 2.1 Notes for using this manual

#### 2.1.1 Information signs / symbols in the manual / on the cleaning machine



This symbol warns about the risk of injury from electricity.



This symbol warns about the risk of injury from flammable substances.



This symbol warns that a potentially explosive atmosphere can occur in the indicated area.



This symbol warns about injuries from hot surfaces and liquids.



This symbol provides a general warning about the risk of injury.



This symbol prohibits the use of any kind of ignition source in this area.



This symbol indicates the check of the quick coupling connections (correct seating, shut-off valves).



This symbol indicates a risk of property damage.



This symbol indicates supplementary information.

## 2.1.2 Signal words in this manual

- Danger** The "danger" signal word warns about severe injuries with risk of fatal injury.
- Warning** The "warning" signal word warns about severe injuries.
- Caution** The "caution" signal word warns about slight to medium injuries.
- Attention** The "attention" signal word warns about property damage.

## 2.2 Safety instructions for use of the cleaning machine

First, strictly make yourself familiar with the safety instructions before start-up.

A summary of the safety instructions can be found here. These are shown again in this operating manual before the respective handling instructions.

**Intended use** This cleaning machine is exclusively intended for cleaning lubricants\* from mechanical precision parts such as dismantled and not dismantled watch movements using solvent-based cleaning and rinsing media (see Chapter 8).

This cleaning machine is not suitable for cleaning or separating chips!

The smallest parts placed in the cleaning basket must not be smaller than 0.355 mm! For information: Smaller particles can be rinsed into the machine through the meshes of the cleaning basket and sieve insert on the bottom of the cleaning chamber and can cause damage, e.g. to the valves.

Flammable liquids can be used as cleaning and rinsing media when used as intended. However, it is not permitted to operate the cleaning machine in an environment with potentially explosive atmosphere of gases, fumes or dusts.

\*greases, oils (also resinified), graphites etc.

**User** The cleaning machine must only be operated by trained personnel in accordance with this operating manual.

**Handling of the machine** Due to its weight the cleaning machine must be handled by 2 persons!

**Inspection for damage** Examine the cleaning machine and mains power cable for transport damage. Do not start up the cleaning machine in the event of detected damage.

**Mains power connection** For safety reasons, the cleaning machine must only be connected to a grounded socket in accordance with the regulations. The technical details of the rating plate must match the available connection conditions, particularly mains voltage and connected load.

<b>Prevention of electrical accidents</b>	<p>Keep the installation area, case and controls dry. Protect against ingress of moisture. Unplug the mains plug during filling, maintenance and care of the cleaning machine, suspicion that liquid has penetrated, operating faults and after use.</p> <p>The cleaning machine must only be opened by trained staff.</p>
<b>Installation</b>	<p>The cleaning machine must be installed at a dry and sufficiently ventilated place for the extraction of vapours of the cleaning and rinsing media from the area of the media tanks filled with these media.</p> <p>The installation surface must be smooth and flat for application-related reasons.</p>
<b>Ambient temperature</b>	<p>The maximum permitted ambient temperature is 30 °C.</p>
<b>Exhaust air equipment</b>	<p>The intended exhaust air equipment (exhaust air pipes with maximum length 5 m or activated carbon unit) for them must be installed at the ventilation openings (cleaning machine rear side) before start-up.</p>
<b>Media (cleaning / rinsing solutions)</b>	<p>Only permitted media must be used in this cleaning machine. Observe the information in <i>Chapter 8</i>.</p> <p>The cleaning machine is only permitted to be operated with the connected and correctly filled 4 original media tanks included in the scope of delivery (see <i>Chapter 4.4</i>).</p>
<b>Fire and explosion hazard</b>	<p>Ignitable solvent vapours can escape in the case of improper operation (without exhaust air connection) and during replacement of the cleaning and rinsing media.</p> <p>Smoking and open ignition sources in the cleaning machine surroundings, particularly in the immediate vicinity of the zone marked with the appropriate danger symbol are therefore prohibited.</p> <p>Strictly observe the safety instructions specified in this manual to prevent such hazards.</p> <p>In the event of liquid discharge from the cleaning machine (amount &gt; droplets), the cleaning machine must no longer be operated for safety reasons.</p> <p>Maximum one day's requirement of the solvents used is permitted to be stored in the surroundings of the cleaning machine at a minimum distance of 3 m from the cleaning machine.</p>
<b>Hazards from solvents</b>	<p>Observe the specified safety measures in the safety data sheets of the respective media used. This also applies with respect to solvent vapours.</p>
<b>Hot surfaces</b>	<p>Depending on the operating time of the cleaning machine, surfaces, particularly the inner wall of the drying chamber, can become very hot (max. approx. 65 °C).</p>
<b>Cleaning basket</b>	<p>The black Elma basket holder (Art. No. 105 3905) is delivered as standard. It is used for attaching electropolished baskets, baskets made from stainless steel, plastic-coated baskets and plastic baskets. Only electropolished baskets may be used in the blue Elma basket holder (Art. No. 105 3162 Accessories).</p>

- The maximum load weight of the cleaning basket with cleaning parts is max. 100 grams. (80 mm basket) or max. 60 grams (64 mm basket)
- Ensure even balanced loading of the cleaning basket for fast rotations around the axis of the cleaning basket.
- Pay attention when inserting the basket holder that it is attached correctly (ball pressure protection engaged).
- Reduce the spinning speed in the case of critical loading.
- Opening cleaning chamber** The cleaning chamber must not be opened during operation. Solvents can spray out!
- Shipment of the machine** Fast rotating cleaning basket!
- Risk of explosion during transport! Strictly empty the media container before shipment and also ensure that the cleaning chamber is emptied!
- Only use the original packaging to prevent transport damage.

### 3 Product description

The Elmasolvex®VA is a completely automatic cleaning machine for cleaning mechanical precision parts.

With innovative product characteristics, the Elmasolvex®VA cleaning machine provides a high standard of cleanliness with certified compliance with the EU regulations for unit and explosion safety for cleaning with flammable solvents (see Declaration of conformity, *Chapter 3.5*).

#### 3.1 How it Works

The cleaning and rinsing media are drawn into the cleaning chamber one after the other using a vacuum from the media tanks in the bottom part of the cleaning machine.

The cleaning is then performed under vacuum conditions with multiple frequency ultrasound technology using rotation or using oscillation without ultrasound technology. There are different previously programmed standard programs and cleaning programs freely programmable by the user available for the microprocessor-controlled cleaning process.

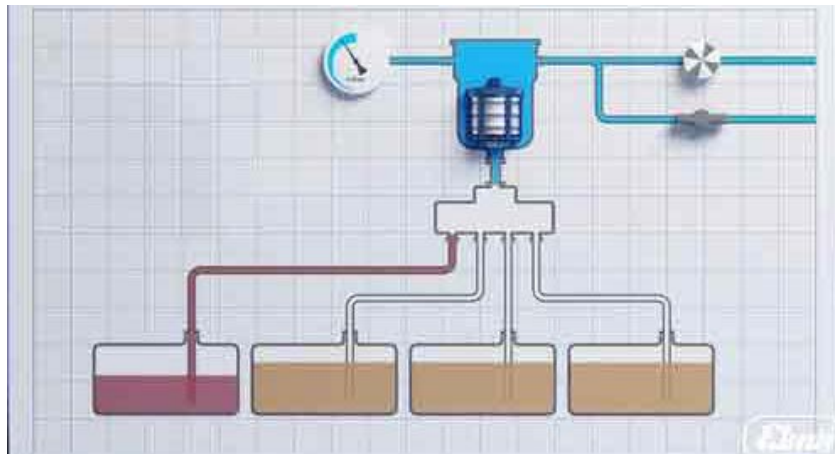

Fig. 3.1.1 Schematic diagram of the functional principle



Fig. 3.1.2 View of cleaning basket in cleaning chamber

## 3.2

### Product Features

- Safe TÜV-certified solvent-based, water-free 4-stage cleaning and rinsing, also with flammable solvents in accordance with the applicable EU safety regulations, certified by TÜV Rheinland.
- Cleaning with vacuum technology below 130 mbar absolute also enables access of the cleaning and rinsing media to otherwise not accessible or inadequately accessible areas of geometrically complicated parts.
- Cleaning and rinsing 3 times, all supported as required with multiple frequency ultrasound of the switchable frequencies 40 and 80 kHz, in Normal, Sweep or Pulse operation.
- Microprocessor-controlled and permanently monitored cleaning processes.
- Gentle vacuum drying with radiant heat below 100 mbar absolute, supported if necessary by spinning up to 1400 rpm.
- Predefined standard cleaning programs.
- Additional cleaning programs freely definable by the user are possible.
- Reliable extraction of the solvent vapours via exhaust air connections to the open air or absorption in an optional activated carbon based absorber unit.
- Suitable for solvents with flashpoint  $\geq 12$  °C.

### 3.3

#### Scope of delivery

- Elmasolvex<sup>®</sup>VA cleaning machine
- Elma basket holder for 5 basket inserts Ø 80 mm (optional accessories) (see *Chapter 6.2*)
- 4 spare suction filters for media tanks (see *Chapter 9.2*)
- Mains cable
- Funnel
- USB cable (Software update / Software Elmasolvex VA Tools)
- Allen key 1.5 mm for mounting the protective grille
- 2 plastic plugs (guiding rail see *Chapter 4.2*)
- Allen key 5 mm for mounting the connecting kit
- Connecting kit for exhaust air tubes
- Operating manual

### 3.4



#### Optional accessories

- movement holders for not dismantled watch movements for accommodation of up to 12 movements (Art. No. 104 6733)
- Holders for bridges and plates (Art. No. 104 6153)
- Basket inserts with different division and height, electro polished or plastic-coated design
- Miniature basket
- Pager – hand-held device for mobile remaining time display of the cleaning program
- Activated carbon unit for absorption of solvent vapours (alternative extraction to the discharge tubes from the scope of delivery)

### 3.5

## CE conformity

This small parts cleaning machine fulfils the CE marking criteria with regard to the Machinery Directive 2006/42/EC, the EMC Directive 2004/108/EC and the ATEX Directive 94/9/EC.

<b>EU-Konformitätserklärung / Declaration of conformity Déclaration de conformité CE / Dichiarazione di conformità / Confirmación CE</b>	
Wir / We / Nous / Noi / Nosotros:	
 Elma Schmidbauer GmbH, Gottlieb-Daimler-Str. 17, 78224 Singen / Hohentwiel Deutschland / Germany / Allemagne / Germania / Alemania	
erklären in alleiniger Verantwortung, dass das Produkt <i>declare under our sole responsibility that the product; déclarons sous notre seule responsabilité que le produit; dichiariamo sotto la nostra unica responsabilità che il prodotto; declaramos bajo la responsabilidad única que el producto</i>	
Bezeichnung / name / nom / descrizione / denominación:	<b>(Uhren-) Kleinteile-Reinigungsmaschine</b>
Typ / type / typ / tipo / tipo:	<b>Elmasolvex VA – (1xxxxx056 – 1xxxxx126)</b>
auf das sich diese Erklärung bezieht, mit den Bestimmungen der folgenden EG-Richtlinie(n) und Norm(en) oder normativen Dokument(en) übereinstimmt: <i>to which this declaration relates, is in conformity with the provisions of following EC-Directive(s) and standard(s) or normative document(s):                  auquel se réfère cette déclaration, est conforme aux dispositions de la (des) directive(s) CE et à la (aux) norme(s) ou document(s) normatif(s) suivants:                  a cui si riferisce la presente dichiarazione, è conforme alle disposizioni della/e seguente/i direttiva/e e norma/e CE o al/ai seguente/i documento/i dispositivo/i:                  al que se refiere la presente declaración cumple con las disposiciones de la(s) siguientes directiva(s) comunitaria(s) y norma(s) o con lo(s) documento(s) normativo(s):</i>	
<b>Maschinenrichtlinie</b> <b>2006 / 42 / EG (EC / EEC)</b>	<i>(machinery directive / directive aux machines / direttiva machine / directiva de máquinas)</i>
Harmonisierte Normen EN ISO 12100; EN ISO 13849-1; EN 1127-1 Abschnitt (chapter / section / sezione / párrafo) 1-5, 6.1-6.5, 7	<i>(harmonized standards / standards harmonisés / standard armonizzati / normas armonizadas)*</i>
<b>EMV-Richtlinie</b> <b>2014 / 30 / EU (EC / EEC)</b>	<i>(EMC-directive / CEM-directive / direttiva CEM / directiva CEM)</i>
Harmonisierte Normen EN 61326-1	<i>(harmonized standards / standards harmonisés / standard armonizzati / normas armonizadas)*</i>
<b>RoHS-Richtlinie</b> <b>2011 / 65 / EU (EC / EEC)</b>	<i>(RoHS-directive / directive RoHS / direttiva RoHS / directiva RoHS)</i>
Für die <b>Explosionssicherheit</b> kamen folgende Normen* zur Anwendung: <i>The safety against explosion is based on the following standards*/la sécurité contre les explosions est basé sur les normes* suivantes: / per la sicurezza contro le esplosioni sono state applicate le seguenti norme*/para la seguridad contra explosiones se han aplicado las normas* siguientes:</i>	
<b>EN 60079-0; EN 60079-26; EN 13463-1; EN 13463-5; EN 13463-6; EN 13463-8; EN 1127-1 Abschnitt (chapter / section / sezione / párrafo) 1-5, 6.1-6.4, 7; EN 60079-10-1</b>	
Zusätzlich gegeben:	<i>(Additionally tested / en outre testé / sono stati inoltre testati / comprobación adicional):</i>
<b>Sicherheitskonzept in Anlehnung an:</b>	<i>(safety concept according to: / concept de sécurité en référence à:/concetto di sicurezza in conformità a: / concepto de seguridad según:</i>
<b>ATEX-Richtlinie</b> <b>94 / 9 / EWG (EC / EEC)</b>	<i>(ATEX directive / ATEX directive / direttiva ATEX / directiva ATEX)</i>
Die Dokumentation wurde bei der benannten Stelle <b>0035 (TÜV Rheinland)</b> unter der Nummer <b>557/Ex-Ab 1901/12</b> hinterlegt. <i>The documentation has been lodged at the named organization 0035 (TÜV Rheinland) with number 557/Ex-Ab 1901/12                  La documentation a été déposée auprès de l'organisme notifié 0035 (TÜV Rheinland) sous le numéro 557/Ex-Ab 1901/12                  La documentazione è stata depositata presso l'organismo citato 0035 (TÜV Rheinland) al numero 557/Ex-Ab 1901/12                  La documentación se ha presentado al organismo notificado 0035 (TÜV Rheinland) con el número 557/Ex-Ab 1901/12</i>	
* Der verwendete Normenstand entspricht dem Stand der Ausfertigung der Konformitätserklärung <i>* The version of the standards used corresponds with the version of the issue of the declaration of conformity                  * L'état des normes utilisé correspond à l'état final de la copie de la déclaration de conformité                  * Gli standard normativi applicati corrispondono allo stato della stesura della dichiarazione di conformità                  * La versión de las normas utilizadas corresponde a la versión de la expedición de la declaración de conformidad</i>	
Name und Anschrift der Person, die bevollmächtigt ist, die relevanten technischen Unterlagen zusammenzustellen: Name and address of the person authorised to compile the relevant technical documentation: Nom et adresse de la personne autorisée pour l'inventaire des documents techniques: Nome e indirizzo della persona autorizzata a costituire la documentazione tecnica pertinente: Nombre y dirección de la persona autorizada para recopilar la documentación relevante:  Michaela Beinroth Gottlieb-Daimler-Str. 17, 78224 Singen	Singen, den 19.4.2016  COO Thomas G. Neher Geschäftsführer / Chief Operations Officer

### 3.6

## Technical Data

<b>Mechanics</b>	
Case external dim. D/H (approx. mm)	600 / 610
Cleaning machine external dim. W/D/H (approx. mm)	600 / 590 / 610
Weight incl. media tanks (approx. kg)	39
Number of media tanks (pcs.)	4
Working volume per media tank (l)	2.5
Exhaust air connections	2 x DN6 (passive)
<b>Electronics</b>	
Mains voltage variant (V AC / Hz)	230 / 50/60
Mains voltage variant (V AC / Hz)	115 / 60
Mains voltage variant (V AC / Hz)	100 / 50/60
Mains input fuse	2 x T4A / 250 V see rating plate
Mains cable cross section	3 x 1.0 mm <sup>2</sup>
Switchable ultrasound frequencies (kHz)	40 / 80
Maximum total power consumption (W)	220
Effective ultrasound power (W), can be regulated 30% - 100%	50
Power consumption in standby (W)	20
Spinning mode speed range freely adjustable up to max. (rpm)	1400
Cleaning / rinsing mode rotation speed range (rpm)	1 - 20
Oscillation / vibration frequency rate (1/s)	1 – 14
Oscillation / vibration mode deflection (°)	1 – 60
Operation sound pressure level <sup>1</sup> (LpAU)	< 70 dB
<b>Accessories</b>	
Individual basket external dimensions D/H (approx. mm)	80 / 10 or 64 / 12
Number of individual baskets in the basket holder	5 or 3
Maximum load, complete cleaning basket (all individual baskets together) (approx. g)	100 or 60
Movement holder maximum movement capacity (pcs.)	12
Activated carbon absorption unit	passive

<sup>1</sup> measured maximum sound pressure level at 1 m distance

### 3.7

## Cleaning machine front side description

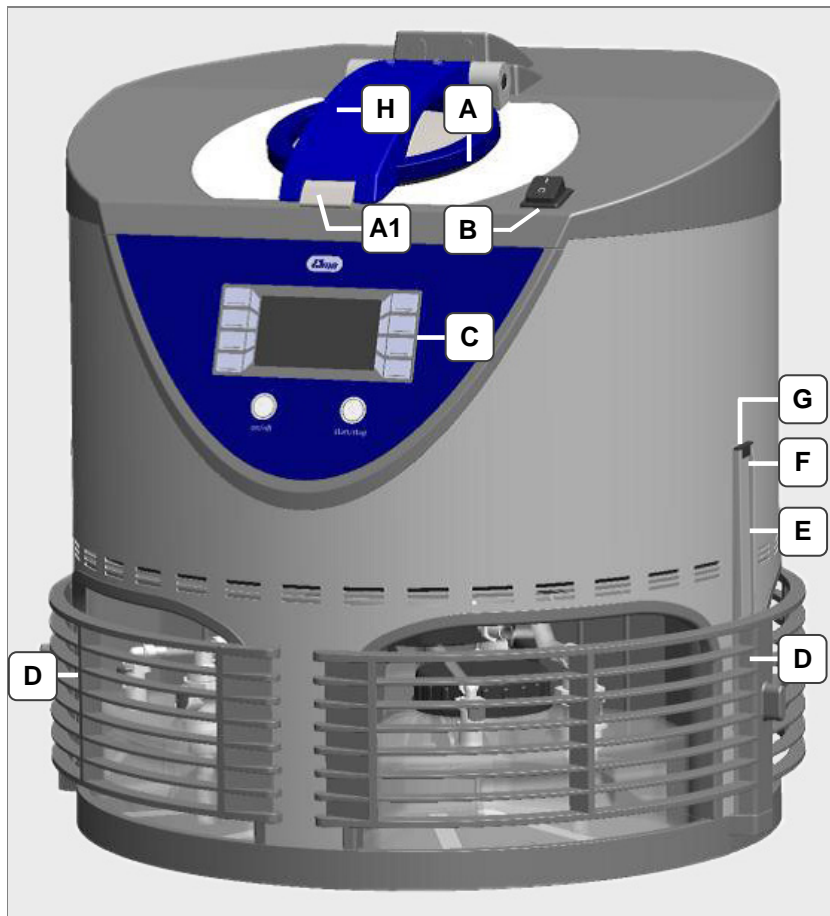

Fig. 3.7.1 View of front side

- A** **Cleaning chamber cover** with snap lock (A1) for engaging the cover
- B** **Main switch** for switching on the cleaning machine
- C** **Control panel with display** Detail description *Chapter 3.9*
- D** **Protective grille above media tanks with cleaning and rinsing liquid** - can be moved up for removal of the media tanks
- E** **Guide rail for media tanks protective grille** The protective grille is inserted here by the user before the first start-up
- F** **Screw as stop for the top end position when moving the protective grille upwards. The screw must be unscrewed by approx. 2 turns after attaching the protective grilles.**
- G** **Plastic cap** must be plugged to the end of the guiding rail
- H** **Screw for venting the cleaning chamber** in the event of a fault (*see Chapter 11.3.2*)

### 3.8

## Cleaning machine rear side description

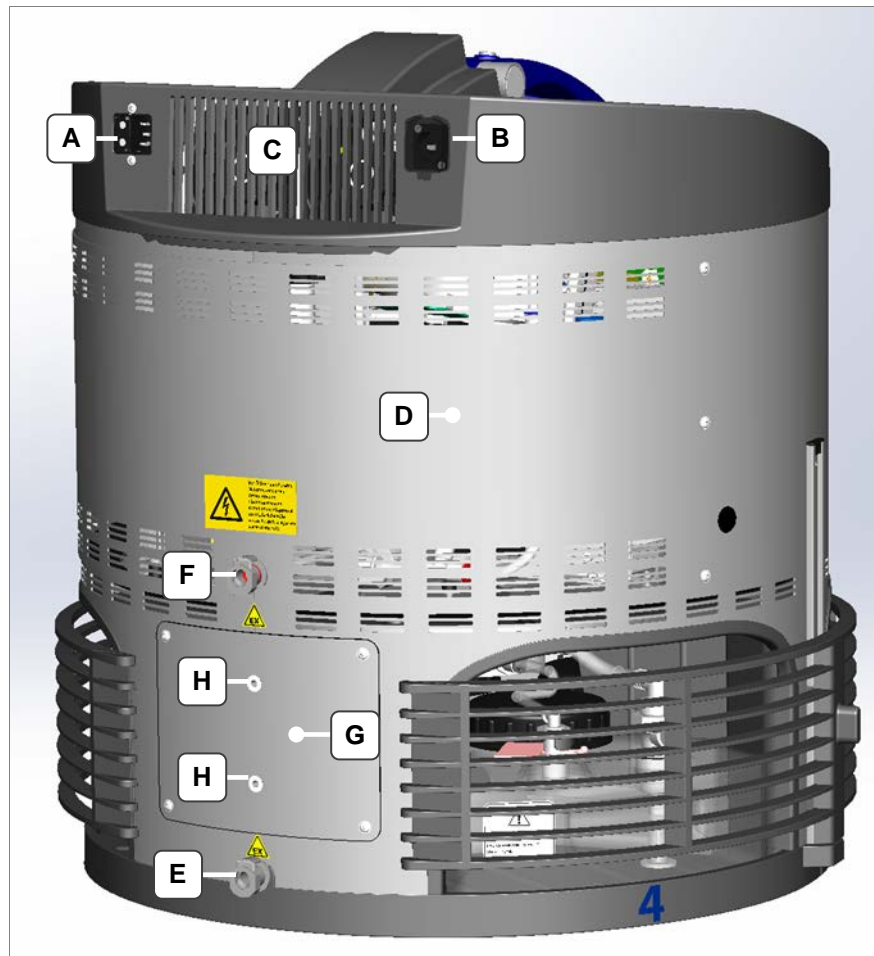

Fig. 3.8.1 View of rear side

- A Connection for mains cable** and slot for fuse
- B USB connection**
- C Fan openings** must be freely accessible for the necessary ventilation and cooling of the cleaning machine
- D Service opening "cleaning machine"**
- E Connection for venting the cleaning chamber** Instructions for use of the Elma exhaust air tube (included in the scope of delivery) or with the Elma activated carbon unit (optional accessory) (*Chapter 4.3 Connecting activated carbon unit or exhaust air tubes*)
- F Connection for venting the media tanks** Connection instructions for use of the Elma exhaust air tube or connection with Elma activated carbon unit (*Chapter 4.3 Connecting activated carbon unit or exhaust air tubes*)
- G Service opening "deflagration protection"**
- H Fastening possibility for the exhaust air tubes**

### 3.9

### Control panel description

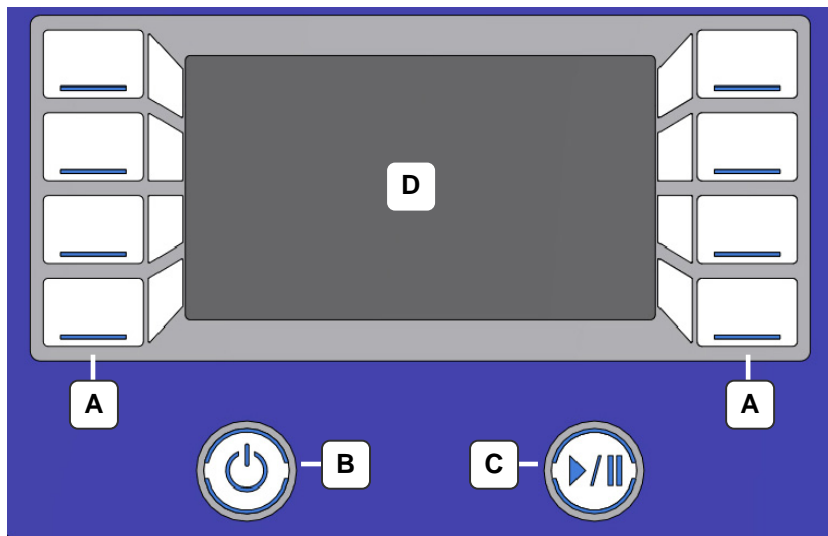

Fig. 3.9.1 View of control panel

- A** **Operating buttons** for selecting functions and settings and navigation in the software menu
- B** **On / Standby button** for switching on the control panel
- C** **Start / Pause button** for starting or interrupting the cleaning process
- D** **Display** shows the setting options and the current status of the cleaning process

### 3.10

### Handling of the control panel

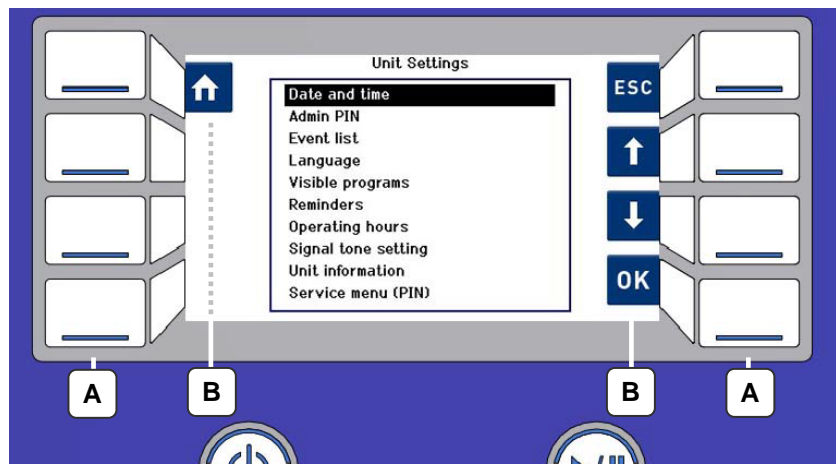

Fig. 3.10.1 Control panel with display and navigation symbols

- A Operating buttons** control the respective navigation symbols shown on the display
- B Navigation symbols** show the context-dependent functions of the appropriate operating buttons



The control panel is not a touch-sensitive user interface (touch screen).

Controls and settings on the cleaning machine are made using the respective operating button assigned to the navigation symbol.

The operating buttons only have to be pressed for a short time ( $\leq 0.5$  sec.) for the actuation.

#### Handling instructions





















Explanation of the handling instructions for operating steps in this manual:

The instruction to press an appropriate navigation symbol always refers to the respective assigned operating button.

### 3.11

## Description of the menu icons

The activation of the respective menu icons using the assigned operating button triggers the following actions:

-  Navigates back to the display *Program Select List* (home screen)
-  Navigates to the *Unit Settings* menu
-  Confirms an entry
-  Used to save the recent changes
  
-  Saves the recent input and returns to the previous display (in the case of program changes the changes must be confirmed beforehand)
-  Navigates to the previous display. Invokes a confirmation screen where the changes can be saved or discarded. 'Cancel' can be selected as option.
  
-  Navigates up by one menu item in the menu selection
-  Navigates down by one menu item in the menu selection
-  Navigates one step to the left in the screen display
-  Navigates one step to the left in the screen display
-  Navigates one step to the right in the screen display
-  Navigates one step to the right in the screen display
-  Increases the value in a selection field
-  Reduces the value in a selection field
-  Adopts an entry
-  Refers to further information
-  Indicates that the pager (optional accessory) can be initialised
-  Refers to the description of a fault
-  Editing program
-  Reset reminder / Remind again

### 3.12 Cleaning chamber description

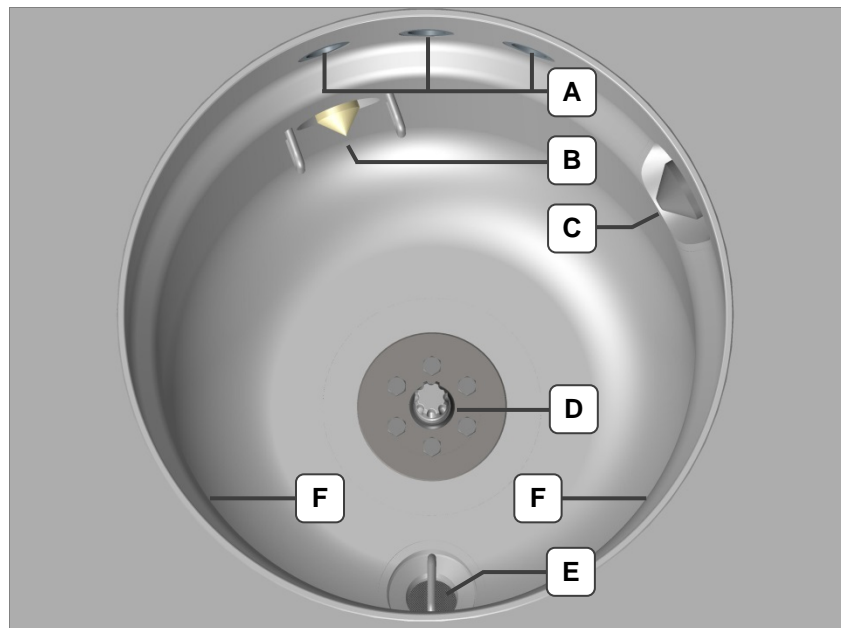

Fig. 3.12.1 View of cleaning chamber

- A Ventilation openings**
- B Filling level sensor optical** Work level with 2 guard rails
- C Filling level sensor** Overfilling level
- D Cleaning basket holder**
- E Sieve insert** (mesh size 0.36 mm) for collecting lost precision parts and coarse particles when draining the cleaning / rinsing liquid from the cleaning chamber. The sieve can be removed for cleaning.  
When reinstalling the sieve, it must be screwed in carefully as far as the stop. Check freedom of movement of the cleaning basket afterwards (collision hazard if the sieve insert has not been screwed in correctly).
- F Heating areas** / radiating surfaces of the 2 heaters with radiant heat for the drying process.



Never operate cleaning machine without sieve insert. Danger of damage in the cleaning machine!

### 3.13 Media tanks description

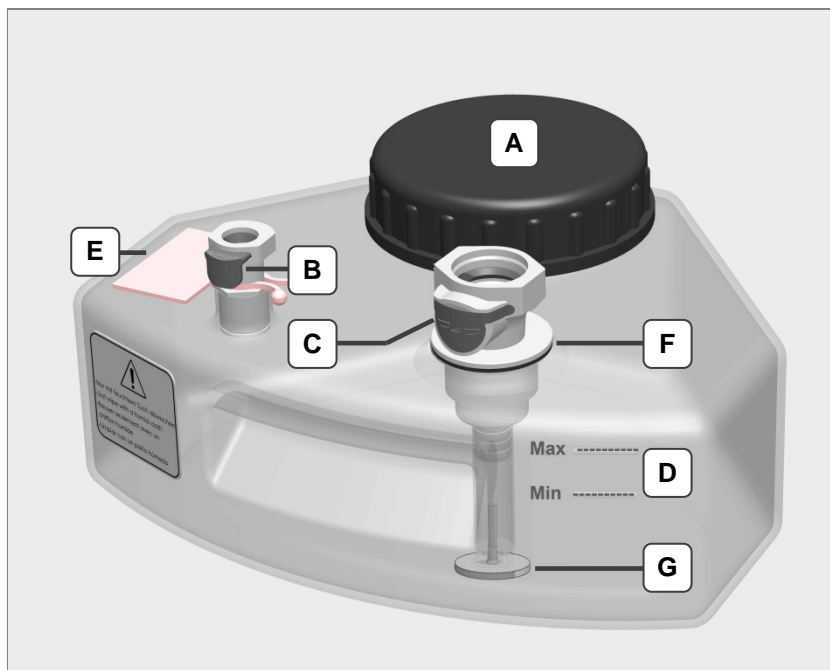

Fig. 3.13.2 Media tanks

- A Screw cap**
- B Media tank (small) venting quick-action coupling with shut-off valve**
- C Media tank (large) quick-action coupling media inlet and outlet with shut-off valve**
- D Filling level marking**
- E Label for marking the media tank**
- F Seal**
- G Suction filter (see Chapter 3.13.1)**

#### 3.13.1 Suction filter functionality

During suction of the medium, the medium must flow through the suction filter (*Fig. 3.13.1.G*) (in this way, only filtered medium reaches the cleaning chamber).

When draining the medium, the suction filter automatically sinks to the bottom of the tank so that unfiltered medium flows into the media tank.

The cleaned soiling thus gets into the canister unhindered and is kept in the media tank during the next filling of the cleaning chamber.



Observe the cleaning and replacement intervals (see *Chapter 9.2.2*).

## 4 Before the initial commissioning

### 4.1 Unpacking and installing the cleaning machine

**Packaging** Keep the packaging for possible service purposes. Any disposal must be made in accordance with the applicable disposal regulations. You can also send the packaging back to the manufacturer or supplier.

**Handling of the cleaning machine** Due to its weight the cleaning machine must be handled by 2 persons! Reach into the openings (where Media containers are placed) to lift up / carry the cleaning machine

**Inspection for transport damage** Inspect the cleaning machine for possible transport damage before the first start-up. The cleaning machine must not be put into operation in the case of recognisable damage. Contact your supplier and the carrier.

**Installation surface** Place the cleaning machine for operation on a stable, level, dry base which is resistant to the cleaning liquid. A smooth installation surface is required to be able to rotate the cleaning machine when changing the cleaning liquid.



**DANGER**

---

Danger of electric shock due to ingress of liquid!

Protect the cleaning machine against the ingress of liquid.

The interior of the cleaning machine is protected against dripping moisture from outside (IP class 20).

However, keep the installation surface and the case dry to prevent electrical accidents and damage to the cleaning machine.

---

**Ambient conditions** Provide sufficient ventilation at the location of the cleaning machine.

The following requirements must be met for safe operation of this cleaning machine:

- Permitted ambient temperature in operation: +10°C to +30 °C
- Permitted relative humidity in operation: max. 80%
- Operation is only permitted in well-ventilated areas
- The surroundings must not have high dust levels
- Operation at max. 2300 m above sea level.  
Operation at above 2300 m can lead to poor drying results.



Fire and explosion hazard!

Ignitable vapours of the cleaning and rinsing media can escape in the case of improper operation without exhaust air tubes / without activated carbon unit and when changing the cleaning liquids.

Smoking and open ignition sources are prohibited in the cleaning machine surroundings.

Maximum one day's requirement of the solvents used is permitted to be stored in the surroundings of the cleaning machine at a minimum distance of 3 m from the cleaning machine.

---

## 4.2

### Attaching protective grilles

The protective grilles in front of the media tanks are not attached when the cleaning machine is delivered.

Procedure for attaching protective grilles:

1. Insert the two protective grilles with the carriage (Fig. 4.2.1.B) in each case from above into the guide rails.
2. Unscrew the grub screws (Fig. 4.2.1.A) at the upper ends of the guide rails by approx. 2 turns.
3. Place the plastic cap (Fig. 4.2.1.C) on to the edge of the guiding rail.

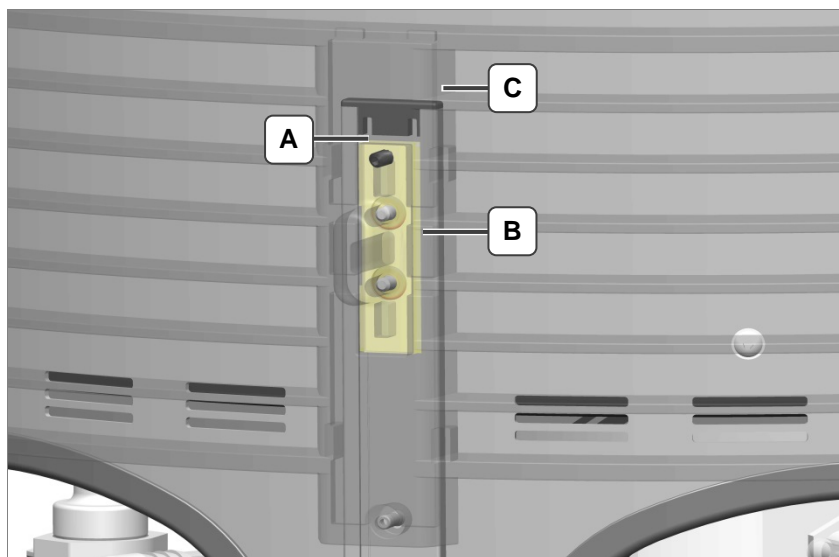

Fig. 4.2.1 Protective grilles guide mechanism

## 4.3

### Connecting activated carbon unit or exhaust air tubes



Due to the process, vapours of the cleaning and rinsing media discharge at the openings provided for them on the rear side of the cleaning machine (*Fig. 4.3.1.A/B*). This area is considered as an area with increased risk of explosion if the safety precautions are not complied with.

Two variants are provided for extracting vapours of the cleaning and rinsing media:

- Activated carbon unit (optional accessory Art. No. 105 3376)
- Exhaust air tubes (included in the scope of delivery) for connection to an authorised central extractor for this or transfer to the open air.

It is mandatory to connect the exhaust air tubes (included in the scope of delivery) to these outlets or to the activated carbon unit (optional accessory) or a permitted central extraction unit. The exhaust air tubes may also be led to the outside.



Attention! Danger from explosion / deflagration in the area of the ventilation openings of the cleaning machine.

Observe the applicable safety regulations for handling flammable media.

Keep all kinds of ignition sources away from the danger area. Prevent ignition sparks from electrostatic discharge.

Use the activated carbon unit or exhaust air tubes protection measures described in this chapter.

Strictly observe the protection measures shown here.

#### Connecting exhaust air tube variant

1. Connect the 2 exhaust air tubes (included in the scope of delivery) to the respective connections *Fig. 4.3.1.A* and *Fig. 4.3.1.B*. In doing so, the connection coupling must audibly engage in each case!

2. Fix the exhaust air tubes using the fixing clamps provided for them. *Fig. 4.3.1. C*



Attention! Danger from explosion / deflagration!

Solvent vapours discharge at the ends of the exhaust air tubes during the cleaning operation. This area is considered as a potentially explosive area.

Either place the ends of the exhaust air tubes (maximum tube length 5 metres) in the open air or connect them to an authorised central extractor.

Keep ignition sources away from the ends of the exhaust air tubes.



The danger areas are marked with the appropriate warning sticker.



Danger of damage to the cleaning machine. The ends of the exhaust air tubes (max. length 5 m) must be freely accessible to a ventilated area and must not be immersed in water!

The Elma activated carbon unit can also be connected to the exhaust air tubes if there is no on site access to the outside or if a permitted extraction unit was not installed.

When using the activated carbon unit, explosion protection is guaranteed provided the specified replacement intervals (see *Chapter 14.3.2*) are complied with. However, unpleasant odours cannot be completely ruled out.

Only use the activated carbon unit from the Elma accessories.

### Connecting activated carbon unit variant

1. Connect the 2 exhaust air tubes (included in the scope of delivery) to the respective connections *Fig. 4.3.1.A* and *Fig. 4.3.1.B*. In doing so, the connection coupling must audibly engage in each case!  
In order to prevent mix-ups for the connections, this coupling has a red marking ring and also the associated connection at the activated carbon unit.
2. Fix the exhaust air tubes using the fixing clamps provided for them. *Fig. 4.3.1.C*.
3. It is possible to fix the exhaust air tubes using the fastening material (included in the scope of delivery, *Fig. 4.3.1.D,F,G*).

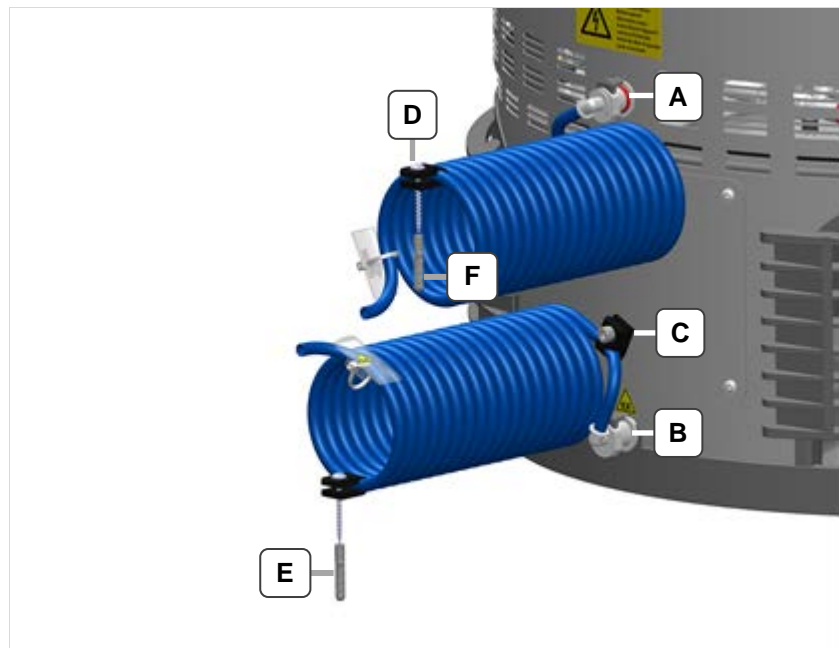

Fig. 4.3.1 Ventilation connections



For further information about connection, handling and servicing of the activated carbon unit see *Chapter 14*.

## 4.4

### Filling media tank

There are 4 media tanks for the respective cleaning and rinsing media located in the bottom area of the cleaning machine.

Fill the media tanks with the cleaning and rinsing media recommended for them (*Chapter 8*).

The individual media tanks must be filled with cleaning or rinsing solution according to the position in the cleaning machine.

Removable labels are attached to the media tanks for individual assignment and recognition of the filled media (*Fig. 4.4.3.E*).

#### Positions of the media tanks

For recognition of the respective position, there are markings on the case and the support surface under the media tanks (1-2-3-4).

Media tank in position #1: **Cleaning medium**

Media tank in position #2: **Rinsing medium**

Media tank in position #3: **Rinsing medium**

Media tank in position #4: **Rinsing medium**

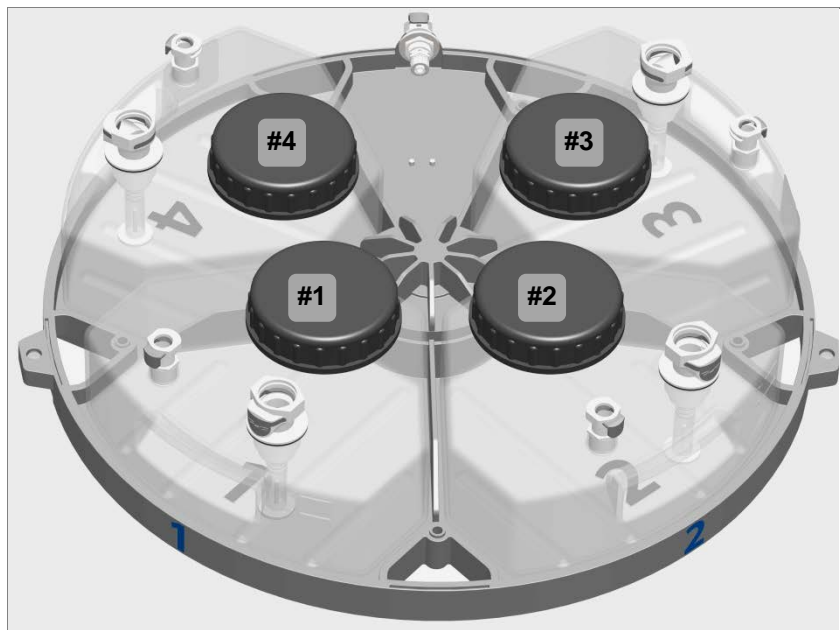

Fig. 4.4.1 Illustration of the positions of the media tanks

**Never operate with unfilled or missing media tanks!**

All 4 media tanks must be filled with suitable operating materials to be able to put the cleaning unit into operation. Operation with unfilled or missing media tanks results in unsatisfactory cleaning results or automatic abortion of the cleaning process.

**Only use permitted operating materials.**

Only permitted operating materials must be used for safety reasons and to prevent cleaning machine damage.

**Do not remove during operation.**

The media tanks must only be removed when the cleaning machine is switched off (empty cleaning chamber) for safety reasons.

Observe the instructions for recommended operating materials and restrictions for operating materials (*Chapter 8*).

---



Fire and explosion hazard!

When handling flammable materials, observe the applicable safety regulations according to the safety data sheet of the respective solvent.

Keep all kinds of ignition sources away.

Prevent ignition sparks from electrostatic discharge. Discharge possible electrostatic charges (body charge) by touching any grounded equipment before handling flammable materials: e.g. water tap, metal surface of the case of the cleaning machine or use ESD protective equipment (ESD arm band).

If liquid escapes while replacing the media tank, this must only be removed using a dry cloth (to prevent electrostatic charging).

---

**Procedure for filling media tank**

Start with the media tank #1 (*Fig. 4.4.1.#1*):

1. Push up the covers for the media tanks (*Fig. 4.4.2.A/A*).
2. Unlock the shut-off valves for the tube connections:  
Press the respective unlocking button on the shut-off valve of the media tank (*Fig. 4.4.3.B/C*) and pull the tube connection upwards out of the shut-off valve at the same time.
3. Remove the media tank from the cleaning machine using the recessed handle.
4. Open the screw cap and fill the media tank with the suitable cleaning medium up to a filling level between the *Min – Max* markings (*Fig. 4.4.3.D*).

**!**  
**ATTENTION**

The filling level of the operating materials must always be between the markings (*Fig. 4.4.3.D*) to guarantee proper operation of the cleaning machine and an optimal cleaning result.

Too low a filling level (below the *Min* marking) causes errors in the cleaning program with unsatisfactory results.

Overfilling (above the *Max* marking) can result in liquid discharging at the case outlet at the bottom and possibly destroying the activated carbon unit.

**i**

The volume above the *Max* marking is also used as reserve for possible liquid entrainments.

5. Check the shut-off valves of the quick couplings on the media tank and the media tubes for correct function (*Chapter 4.4.1*).
6. Replace the tank in the cleaning machine.
7. Reconnect the tube couplings to the media tanks. The tube couplings must audibly engage in the shut-off valves. Also visually inspect the secure seating of the tube couplings.

**Attention!** After the engagement, the push buttons on the tube couplings (B and C) must be completely disengaged. Check by shaking and pulling on the tube coupling whether it is correctly connected.

8. Proceed in the same way with the media tanks #2 - #3 - #4 for the rinsing media.

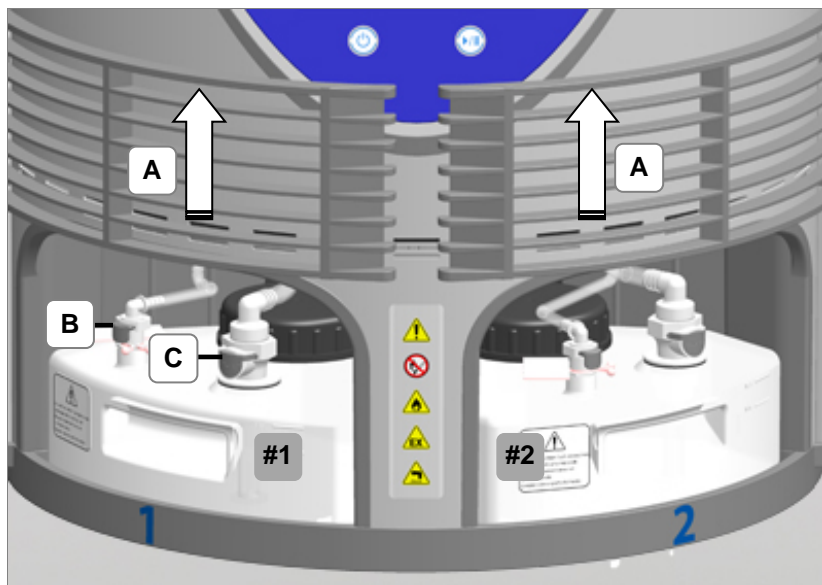

Fig. 4.4.2 Media tank cover opened

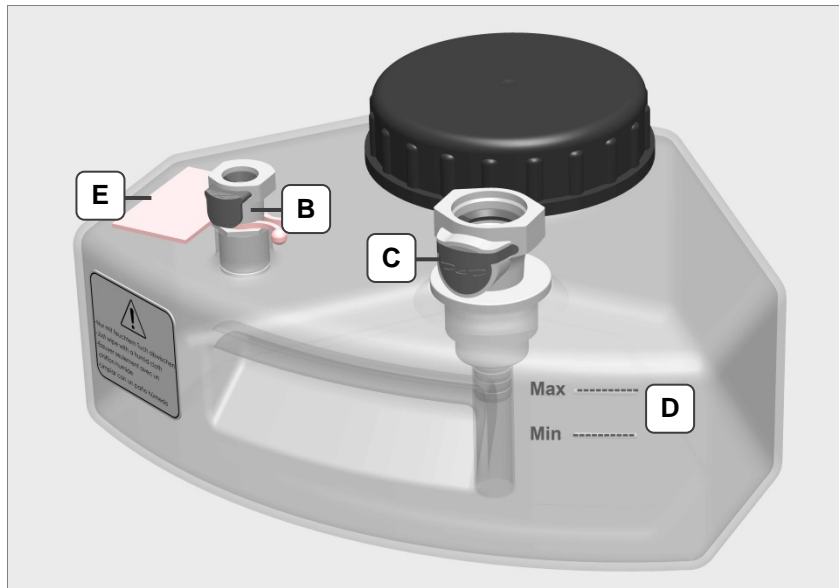

Fig. 4.4.3 Media tanks

#### 4.4.1 Checking shut-off valves of the quick couplings



The shut-off valves of the quick couplings automatically seal the media tanks and the media tubes if both quick coupling parts are not connected to each other. Check the correct function of the shut-off valves at every media change.

##### Procedure

Press the nipple of the shut-off valve a few millimetres into the coupling to check the shut-off function. After releasing, the shut-off valve must spring back outside to the "closed" position (arrow direction).

##### Media tank quick coupling

The shut-off valve (Fig. 4.4.1.1.F) is moveable and in the not connected state must be flush with the guide bar (Fig. 4.4.1.1.G).

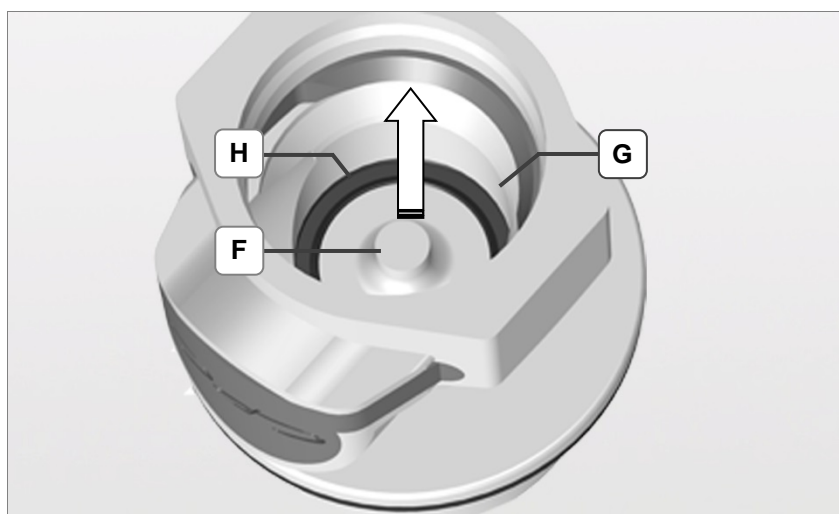

Fig. 4.4.1.1 Media tank quick coupling "closed"

**Media tube quick coupling**

The shut-off valve is moveable. The nipple of the shut-off valve (*Fig. 4.4.1.2.J*) in the not connected state must protrude over the edge of the quick coupling.

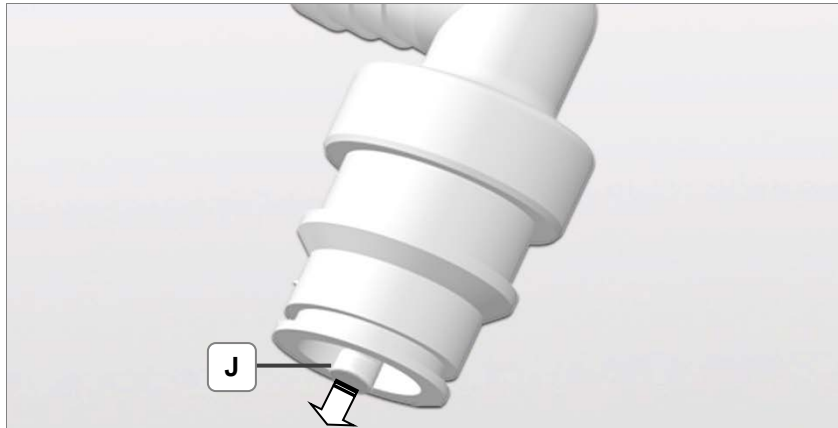

Fig. 4.4.1.2 Media tube quick coupling "closed"

**Checking seal in the quick coupling of the media tube**

Check the seal is seated correctly: *Fig. 4.4.1.3.H* correct seating. *Fig. 4.4.1.4.H* incorrect seating!

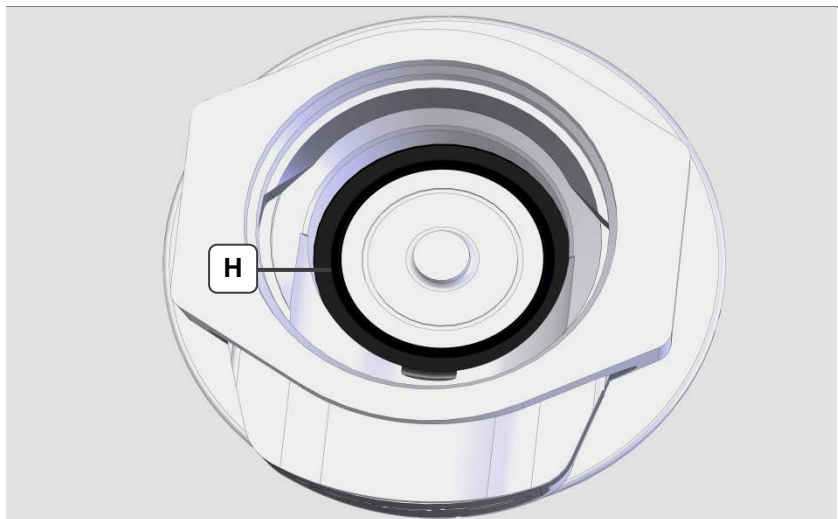

Fig. 4.4.1.3 Seal OK

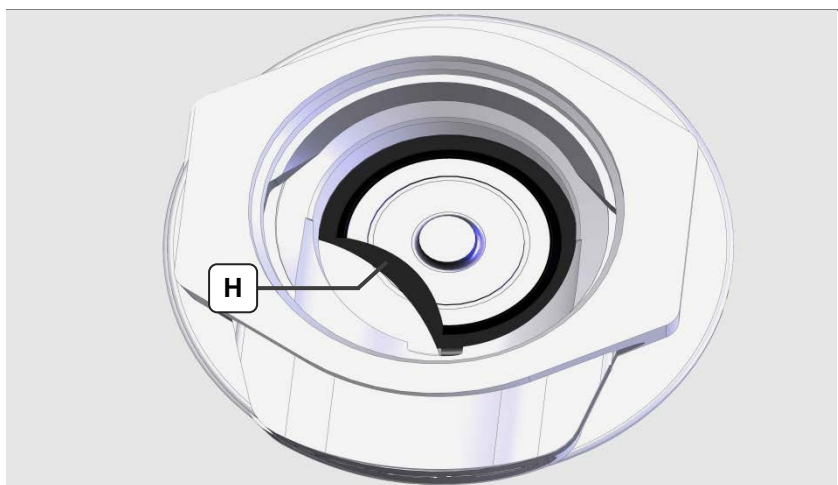

Fig. 4.4.1.4 Seal not OK!

## 5 Initial commissioning

### 5.1 Connecting cleaning machine to mains power supply

- Required grid conditions** The connection conditions must match the information on the rating plate.
- Connecting mains cable** Connect the mains cable (included in the scope of delivery).  
The cleaning machine must only be connected to a grounded power socket.  
The mains plug must only be connected to an easily accessible power socket as it is considered as a disconnecter!

### 5.2 Switching on cleaning machine

- Switching on main switch** Switch on the cleaning machine at the main switch (*Fig. 3.7.1.B*).  
The internal fans are started (fan noise audible).

### 5.3 Selecting language in the display



A language must initially be selected when first switching on (for handling see *Chapter 3.10*). The display does not change to the next step until then.

The language in the display set at the factory is German. Confirm or change the language by pressing the appropriate operating button.

The selected language is shown on the display (*Fig. 5.3.1.A*).



Fig. 5.3.1 Display user language

The display now automatically changes to the interrogation of the filling of the media tanks (*Fig. 6.1.1 Chapter 6.1*).

## 6 Daily cleaning operation

**Switching on main switch** Switch on the cleaning machine at the main switch (Fig. 3.7.1.B).  
The internal fans are started (fan noise audible).

### 6.1 Checking filling levels of the media tanks

**Checking media tank filling level** The retrieval of the filling levels of the media tanks is shown on the display (Fig. 6.1.1).  
Check the filling levels and fill or empty the media tanks if required to the correct filling level (Chapter 4.4).  
Confirm the correct filling levels with **OK**.



**Filling levels of media containers OK?**



**OK**

Fig. 6.1.1 Display *Check filling level of the media tanks*

The display automatically switches to the Start menu with display of the cleaning programs (Fig. 6.3.1).

## 6.2

### Loading and inserting basket holder

The cleaning machine is equipped with a basket holder at the factory.



Note the following instructions before operation of the basket holder in order to prevent damage to the product to be cleaned and cleaning machine.

Only use the original Elma basket holder.

The maximum load weight of the basket holder is 100 grams.

Do not clean parts or clean off dirt particles whose diameter is smaller than 0.355 mm!

#### Opening cleaning chamber

Open the cover of the cleaning chamber by slightly lifting the snap connector at the front end of the cover handle (Fig. 3.7.1.A1).

#### Removing cleaning basket

The basket holder mounting shaft is only placed in the coupling of the basket holder (locking by engaging in a ball gripper).

Remove the basket holder by pulling upwards.

#### Opening cleaning basket

Press the basket holder locking down (Fig. 6.2.1.A1) and simultaneously turn (Fig. 6.2.1.A2) anticlockwise to open the basket holder (bayonet connection).

The individual basket inserts (Fig. 6.2.2.B) can now be removed from the basket holder (Fig. 6.2.2.C).

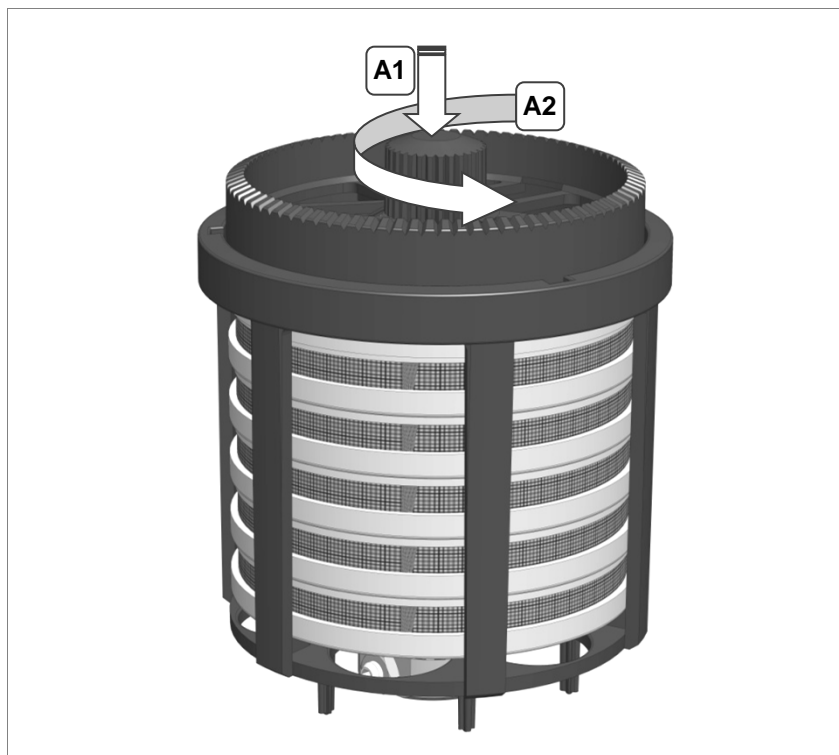

Fig. 6.2.1 Opening basket holder

### Loading basket inserts

The baskets are designed differently for accommodation of the various parts to be cleaned. Pay attention during the loading that sensitive parts are placed with appropriate care in the suitable basket compartments.

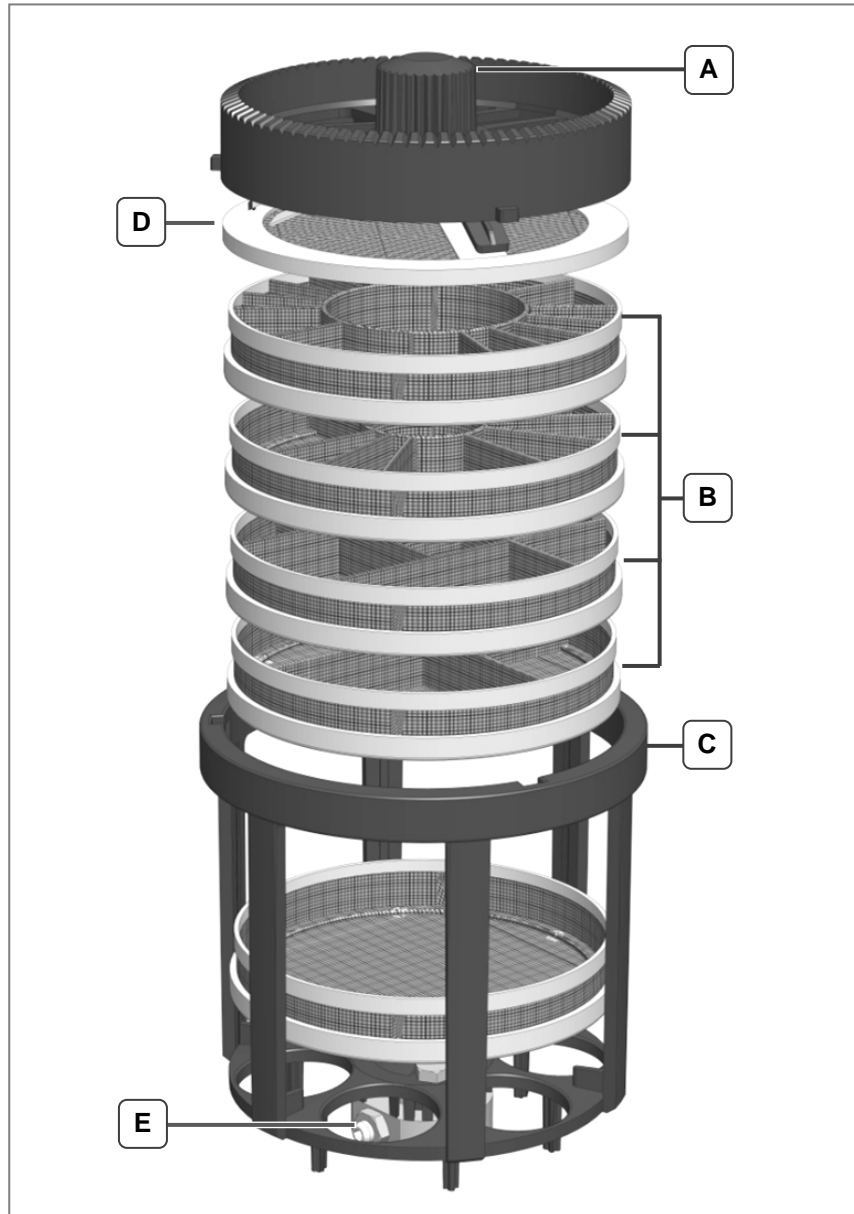

Fig. 6.2.2 Basket holder structure

### Loading and closing cleaning basket

Stack the loaded baskets back into the basket holder.

**Attention!** All baskets must strictly be replaced in the basket holder to be able to securely close the basket holder again. In doing so, it is not important whether all baskets are loaded.

Place the basket lid (*Fig. 6.2.2.D*) in the top position.

Lock the basket holder with the basket locking.

**Placing basket holder in cleaning chamber**

**Attention!** Check that the basket holder locking (*Fig. 6.2.2.A*) is correctly locked before placing in the cleaning chamber.

When using third party baskets, check the bottom of the basket holder regularly for signs of wear due to the increased risk of wear (see *Chapter 9.2.3*).

Position the basket holder on the shaft of the rotation seal (*Fig. 6.2.3.A*) at the floor of the cleaning chamber

A ball gripper in the collar bushing fixes the basket holder in the cleaning chamber.

Check the correct fixing of the basket holder: When slightly pulled, the basket holder must remain connected to the shaft of the rotation seal.

Check the seating of the basket holder: If the basket holder can be removed very easily, it was not fixed correctly. Position it again.

If the basket holder is no longer correctly mounted after longer use of the cleaning machine, check the wear on the tothing of the collar bushing (see *Basket holder Chap. 9.2.3*)

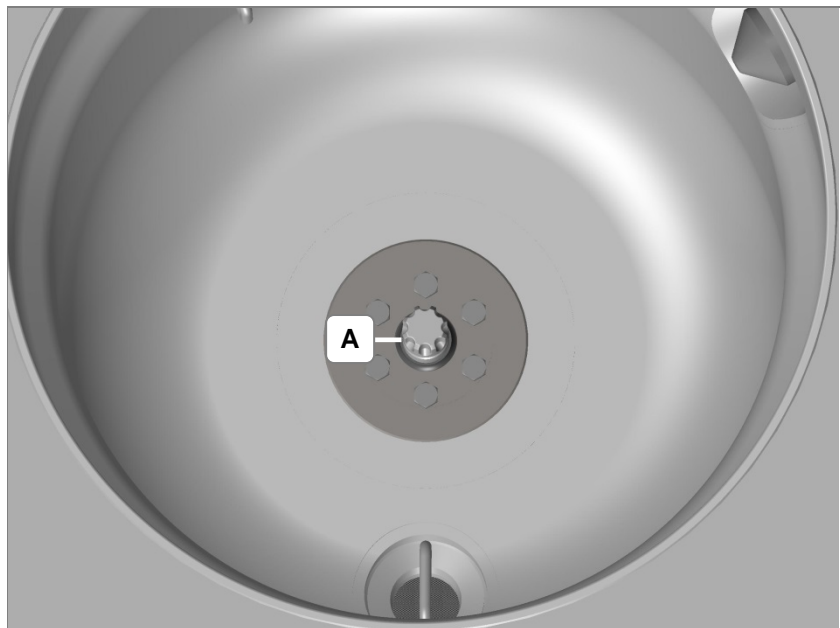

Fig. 6.2.3 Shaft of the rotation seal

**Closing cleaning chamber**

Close the cover of the cleaning chamber. In doing so, the cover must audibly engage.



If the cover is not correctly sealed and therefore the cleaning chamber cannot be deflated, an appropriate error message is shown on the display at the start of the cleaning process.

## 6.3 Selecting and starting cleaning program



Three predefined cleaning programs are stored at the factory and are displayed in the program selection (Fig.6.3.1).

These are differentiated by the duration of individual cleaning and rinsing times and by different ultrasound modes:

- Standard** Cleaning program for normal soiling of the parts to be cleaned.
- Short** Cleaning program for normal soiling of the parts to be cleaned.
- Intensive** Cleaning program for normal soiling of the parts to be cleaned.



Four special programs for particular applications are also stored (description Chap. 6.3.1). These are displayed in the *Visible Cleaning Programs* display setting and can be displayed in the program selection if required (see Chap. 7.1.5).

### Selecting cleaning program

Select the required cleaning program by navigating with / .

### Confirming selection

Confirm the selection with .



Fig. 6.3.1 Display *Program Select List* (home screen)

### Insert basket holder, close cover

The instruction to insert the basket holder and close the cover is shown on the display (Fig. 6.3.2).

If the basket holder has not yet been inserted, now load and insert the basket holder in the cleaning chamber (for procedure, see Chapter 6.2).

Close the cover of the cleaning chamber.



Fig. 6.3.2 Display *Insert basket holder and close lid*

**Starting cleaning program**

Press the now flashing Start/Pause button to start the cleaning program (Fig. 3.9.1.C).

The blue LED in the Start/Pause button lights.

**Safety test**

An automatic safety test is performed here during first start-up of the cleaning machine.

This safety test is also performed the first time any cleaning program is started after disconnection of the cleaning machine from the mains power supply (e.g. switching off using main switch).

The safety test takes approx. 1-2 minutes. The progress is shown on the display (Fig. 6.3.3).

The safety test can be aborted with the button **ESC**. The *Cancel safety test?* dialogue box is displayed.

The *Program Select List* display is shown when the button **OK** is pressed. The specified cleaning program is not started.

The safety test is continued by pressing the button **ESC**.



The safety test cannot be bypassed!

After completion of the cleaning program, this safety test is no longer performed for the next program start.

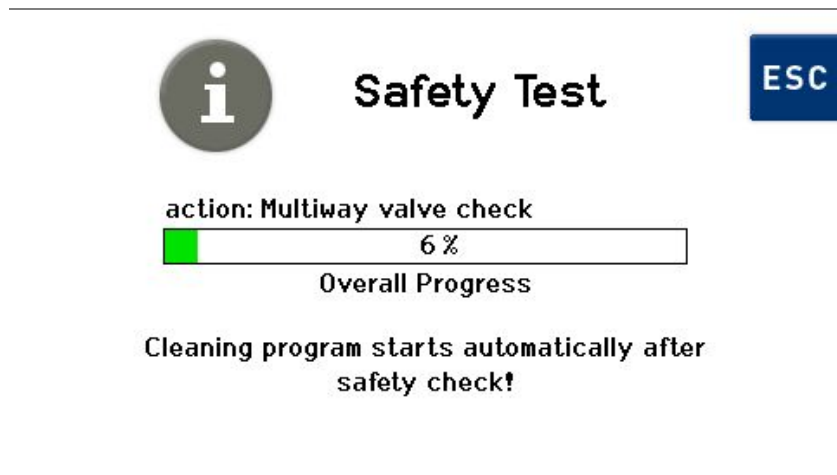

Fig. 6.3.3 Display *Safety test progress*

**Initialisation phase**

After performing the safety test, the cleaning machine automatically continues with the selected cleaning program. After a short initialisation phase of 30 seconds, the cleaning machine starts filling the cleaning chamber by the resulting vacuum.

This process is shown on the display (*Fig. 6.3.4*).



Fig. 6.3.4 Display *Status of the program progress*

**Start of the cleaning program**

After completion of the initialisation phase, the corresponding notification in the display is cleared and the cleaning program is started.

The remaining time until the end of the cleaning program is displayed.

**Initialising pager (optional accessory)**

If you have a pager, you can initialise this now (for description, see *Chapter 15 Appendix 2: Pager*).

**Progress display of the cleaning program**

The detailed progress of the cleaning program can be shown on the display (*Fig. 6.3.5*): Press the corresponding operating button **i** (*Fig.6.3.4*) to display this function.

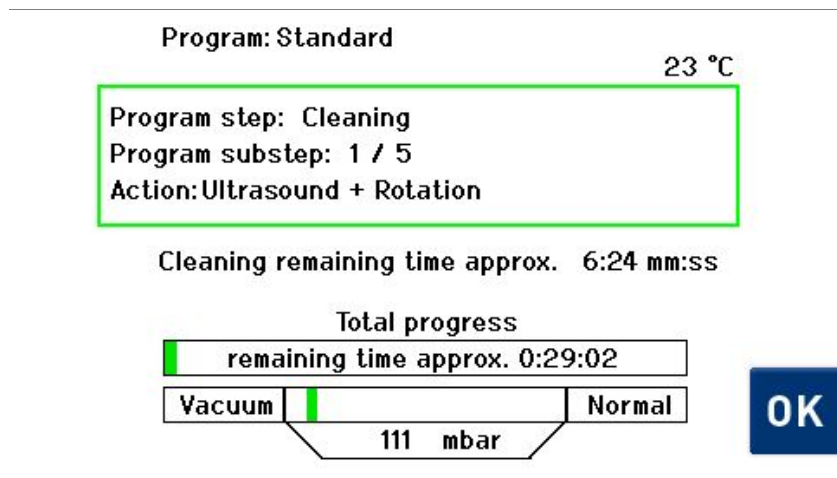

Fig. 6.3.5 Display *Detail information for the program progress*

**Cleaning program end**

Press **OK** (Fig. 6.3.5) to return to the previous display.

The end of the cleaning program is notified by an ascending tone audible signal sequence.

The corresponding indication is shown on the display.

Press **OK** to confirm this notification and switch off the signal tone (Fig. 6.3.6).

The display for selection of the cleaning program (Fig. 6.3.1) is shown on the display again.



Fig. 6.3.6 Display *Program finished*

Now you can open the cover of the cleaning chamber and remove the basket holder.



**CAUTION**

Depending on the program duration, the cleaning chamber interior wall is still hot (<60 °C) and the basket holder is still warm (<45 °C) immediately after the program end.

If necessary let the basket holder cool down for some time in the cleaning chamber.

## 6.3.1 Special Programs

In addition to the 3 predefined cleaning programs for all usual applications, 4 predefined programs for special applications are also available. These can be displayed as described in *Chap. 7.1.5*.

<b>Standard Drying</b>	Program for drying (complete drying step) in the event of cancellation of the cleaning program (cleaning basket wet).
<b>Movement holder V2 Prg</b>	Special cleaning program when using the W2V movement holder (without spinning).
<b>Epilamisation_Episorf</b>	Special program for epilamisation according to the method of the company Surfactis (on request).
<b>After Drying</b>	Program for additional drying if the standard drying was not sufficient (cleaning basket moist).

## 6.4

### Interrupting / aborting cleaning program



Risk of injury from fast rotating cleaning basket!

Never open the cover of the cleaning chamber during the cleaning process!

Never reach into the rotating cleaning basket!

If required, cancel the cleaning program in a controlled way.

#### Interruption of the cleaning program

Press the Start / Pause operating button (*Fig. 3.9.1.C*) if the cleaning program has to be interrupted for any reason. The display with the pause information (*Fig. 6.4.1*) is shown on the display.

Press the Start / Pause operating button (*Fig. 3.9.1.C*) if you would like to continue with the cleaning program.

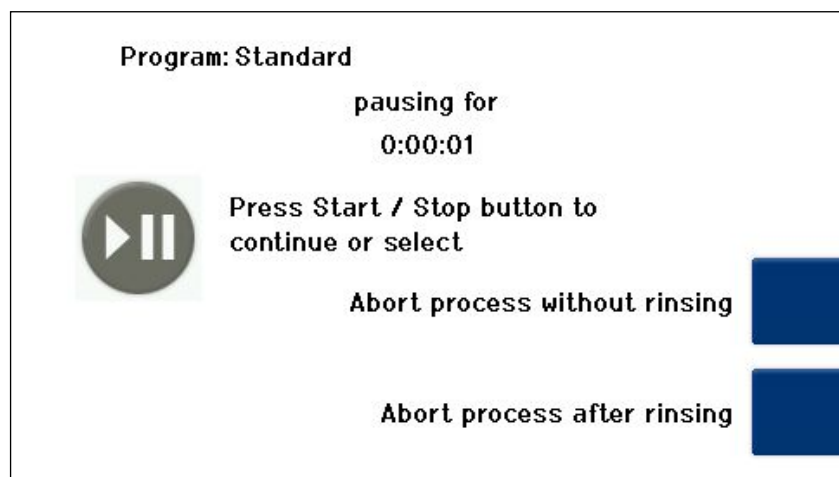



Fig. 6.4.1 Display *Pause*

#### Abortion of the cleaning program

If you would like to definitively abort the cleaning program, there is a selection option whether a rinsing process should still be performed or not.

Press *Abort process without rinsing*  or *Abort process after rinsing*  (*Fig. 6.4.1*).

Information about the abortion of the cleaning program (*Fig. 6.4.2*) is displayed during the abortion process.

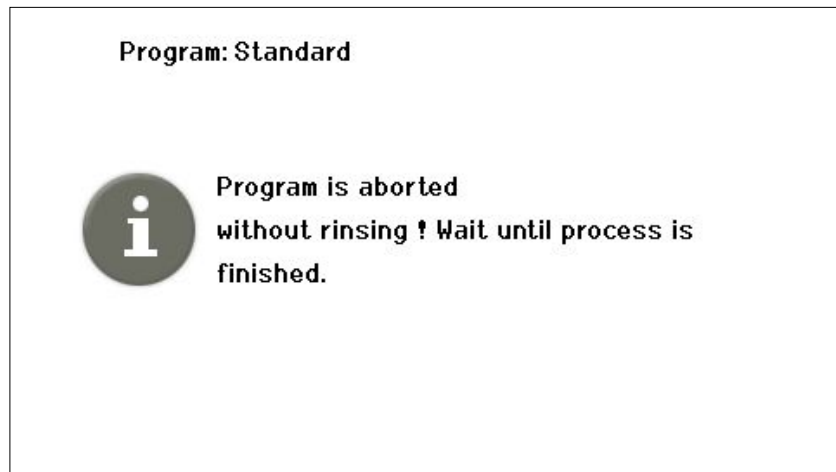

Fig. 6.4.2 Display *Program is aborted*

### Cleaning program end

The end of the cleaning program is notified by an ascending tone audible signal sequence.

The corresponding indication is shown on the display.

Press **OK** (Fig. 6.4.3) to confirm this notification and switch off the signal tone.

The display for selection of the cleaning program (Fig. 6.3.1) is shown on the display again.



Fig. 6.4.3 Display *Program finished*

Now you can open the cover of the cleaning chamber and remove the basket holder.



Depending on the program duration, the cleaning chamber interior wall is still hot (<60 °C) and the basket holder is still warm (<45 °C) immediately after the program end.

If necessary let the basket holder cool down for some time in the cleaning chamber.

## 7 Settings

**i** If an Administrator PIN has been stored by the user (*Chapter 7.1.2*), a request for the Admin PIN is shown on the display. Entries / changes for the cleaning machine settings and cleaning programs are not possible without input of the valid Administrator PIN.

### 7.1 Cleaning machine Settings

It is possible to make various cleaning machine and program settings. These options are described in the following chapters.

The procedure for the operating steps starts in each case from the display *Program Select List* (*Fig. 7.1.1*) and then *Unit Settings* (*Fig. 7.1.2*).



Fig. 7.1.1 Display *Program Select List*

Press  in the Program Selection display to open the Machine Settings display.

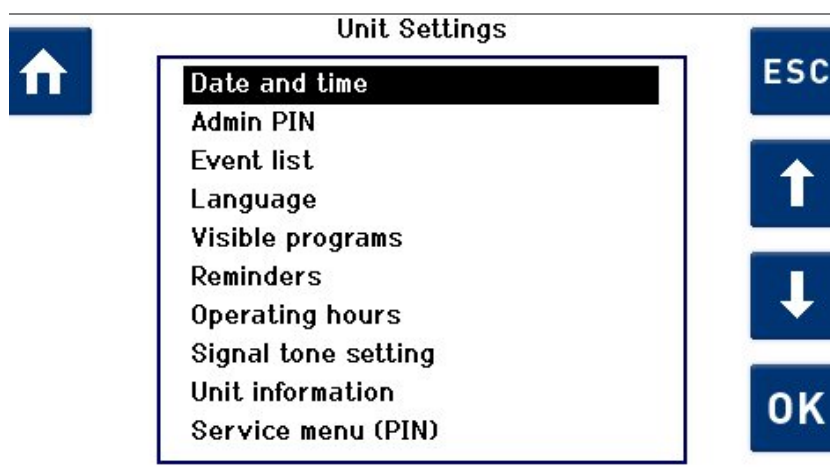

Fig. 7.1.2 Display *Unit Settings*

## 7.1.1

### Date / Time





Date and time are not required for operation of the cleaning machine. However, in the event of cleaning machine faults, date and time are needed to be able to better evaluate faults.

We therefore recommend checking the factory settings and adjusting if necessary during the commissioning.







**Procedure** Starting from the display *Program Select List* (Fig.7.1.1):

1. Press .

The display *Unit Settings* (Fig. 7.1.2) is shown.

2. Using  /  select *Date and time* in the selection list and confirm with .

The *Date and time* (Fig. 7.1.1.1) display is shown.

3. Check whether the settings match the local time and date. If no changes are required, exit from the *Date and time* display using  or .
4. For changes, navigate using  /  to the relevant input fields (black background).
5. Adjust the values using  / .
6. Press  to apply the changes.

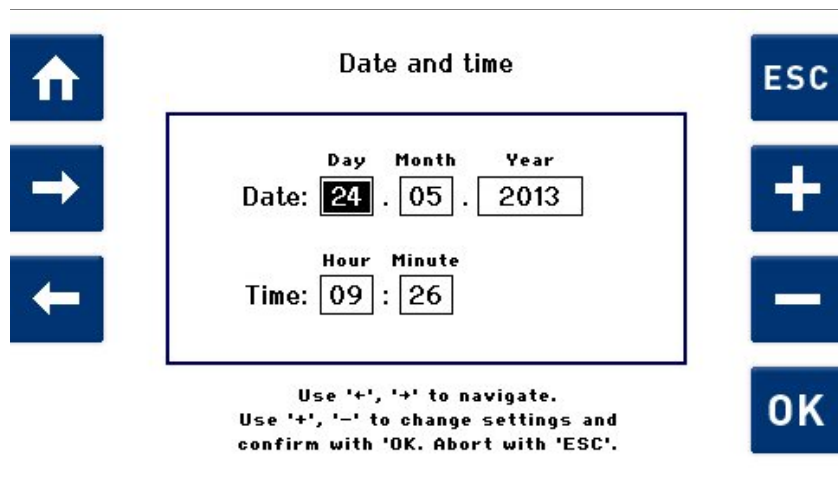

Fig. 7.1.1.1 Display *Date and time*

## 7.1.2 Administrator PIN



The allocation of an Administrator PIN is used to only enable access to the cleaning machine and program settings using an enabling PIN. An Administrator PIN is allocated by the user. The PIN request is deactivated in the factory settings (*Off*): The cleaning machine can be operated without restriction with the factory settings.

### PIN activation procedure

Proceed as follows to allocate an Administrator PIN:

Starting from the display *Program Select List*):

1. Press

The display *Unit Settings* (Fig. 7.1.2) is shown.

2. Using / select *Admin PIN* in the selection list and confirm the selection with .

The *Admin PIN* (Fig. 7.1.2.1) display is shown.

3. In the display (Fig. 7.1.2.1) select *On* by touching / and confirm by pressing .

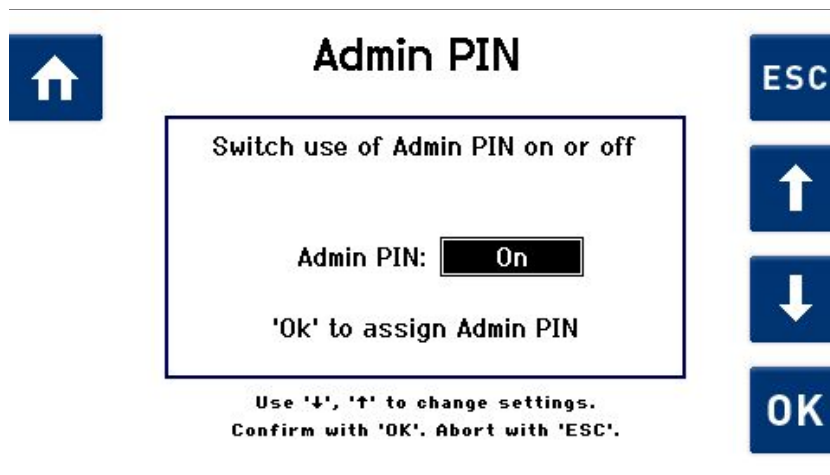

Fig. 7.1.2.1 Selection field for activating / deactivating the Admin PIN

The *Admin PIN* (Fig. 7.1.2.2) display is shown.

The Administrator PIN must consist of 4 digits.

4. Navigate within the line of the digit selection using / .
5. Press to apply the selected digit.
6. Press to save the specified 4-digit Administrator PIN.

A display (Fig. 7.1.2.3) is shown for confirmation of the Admin PIN by inputting it again.

7. Enter the same number again as previously described and press **OK**.

Press **ESC** or **↑** to exit from this display without changes.



Fig. 7.1.2.2 Display *Assign Admin PIN*

The Administrator PIN has now been set. A dialogue box requesting the Admin PIN will be displayed the next time *Program Settings* or *Unit Settings* is called.

If you have forgotten the PIN, press **i** (Fig. 7.1.2.3) and follow the instructions.



Fig. 7.1.2.3 Display *Enter PIN*

### Procedure for deactivating Admin PIN

Proceed as for the Admin PIN activation procedure.

After input of the previously set Admin PIN, select the setting *Off* in the display (Fig. 7.1.2.1) using **↑** / **↓** and confirm the selection with **OK**.

### 7.1.3 Event List



The *Event List* is not needed for normal operation of the cleaning machine. In the event of a fault, the customer can look up which fault it is in the *Event List*. In contrast to the display of any fault or warning message during operation, the entries stored here contain additional information.

The *Event List* contains entries about faults, warnings and information (e.g. performed software updates).

For fault clearance, see Chapter 11.3 *Fault clearance by user*. The entries also provide fault descriptions for technical support or the on-site service technician.

#### Procedure for displaying the event list

In the event of a fault, invoke the *Event List* to obtain further information for the fault and fault clearance. Proceed as follows:

Starting from the display *Program Select List*.

1. Press

The display *Unit Settings* (Fig. 7.1.2) is shown.

2. Using / select *Event List* in the selection list and confirm the selection with .

The *Event List* (Fig. 7.1.3.1) display is shown.

3. Navigate using / in the *Event List* to go through the saved events.

The entries can only be deleted by trained staff.



Event List		
Select Entry ( 13 )		
No.	Description	Date
	7 Program not finished	22.05.2013
	66 Explosion protection	21.05.2013
	16 Program not finished	21.05.2013
	98 Tank overfilled	21.05.2013
	2 Program not finished	21.05.2013
	84 Tank overfilled	21.05.2013
	6 Program not finished	21.05.2013

'↓', '↑' to select event. 'i' show details.  
Back with 'ESC'.

Fig. 7.1.3.1 Display *Event List*

**Procedure for displaying details**

The detailed information view of an event contains important additional information for more precise assessment of the fault.

1. Navigate using  /  in the *Event List* and press  to retrieve further information about the respective entries.

The following display (*Fig. 7.1.3.2*) is shown.

2. Press  to exit from the detail view.



Fig. 7.1.3.2 Display *detailed information view*

## 7.1.4 Changing user language



The user language specified during the first start-up can be changed at any later time.

**Procedure** Starting from the display *Program Select List*):

1. Press

The display *Unit Settings* (Fig. 7.1.2) is shown.

2. Using / select *Set language* in the selection list and confirm with .

The *Set language* (Fig. 7.1.4.1) display is shown.

3. Select the required language using / .
4. Press to apply the changes.

Press or to exit from this display without changes.



Fig. 7.1.4.1 Display *Set language*

## 7.1.5 Visible cleaning programs



**i** The *Visible Cleaning Programs* setting makes it possible to display and hide programs in the *Program Select List* display.

If needed, only "required" cleaning programs can be displayed.





**Procedure** Starting from the display *Program Select List*):

1. Press .

The display *Unit Settings* (Fig. 7.1.2) is shown.

2. Using  /  select *Visible Cleaning Programs* in the selection list and confirm with .

The display *Visible Cleaning Programs* (Fig. 7.1.5.1) is shown.

3. Using  / , select the program which should be displayed or hidden.
4. Press  to activate or deactivate the selection field. Activated programs are marked with a checkmark.
5. Proceed in the same way if other programs should be hidden or displayed.
6. Press  to apply the changes.



Press  or  to exit from this display without changes.



Fig. 7.1.5.1 Display *Visible Cleaning Programs*

## 7.1.6

## Reminders



The *Reminders* menu item enables the activation of reminders for exchange of media and the setting of a general reminder (e.g. change activated carbon filter).

## Procedure Reminders Call

Starting from the display *Program Selection*:

1. Press

The *Machine Settings* (Fig. 7.1.2) display is shown.

2. Using / select Reminders in the selection list and confirm with .

The display *Reminders* (Fig. 7.1.6.1) is shown.

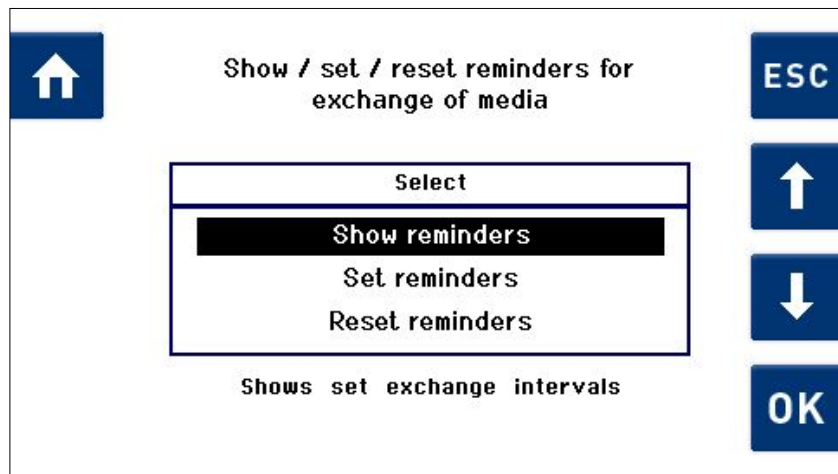

Fig. 7.1.6.1 Display *Reminders for exchange of media*

### Reminders for exchange of media



The menu item *Reminders for exchange of media* enables the activation of reminders for an exchange of media and setting of the reminder intervals.

3. Using / select *Reminders for exchange of media* in the selection list and confirm with .  
If you would like to exit from this display, press or .

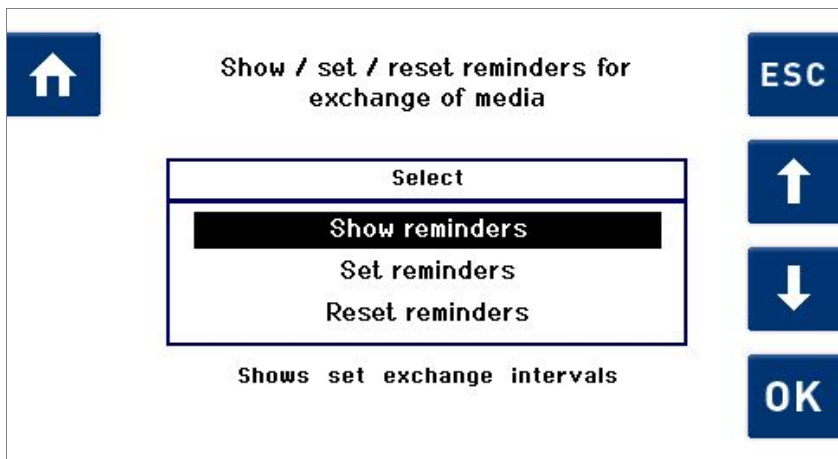

Fig. 7.1.6.2 Display *Reminders for exchange of media*

**Procedure for showing reminders**

Using **↑** / **↓**, select *Show reminders* in the selection list and confirm with **OK**.

The following display (*Fig. 7.1.6.3*) is shown.

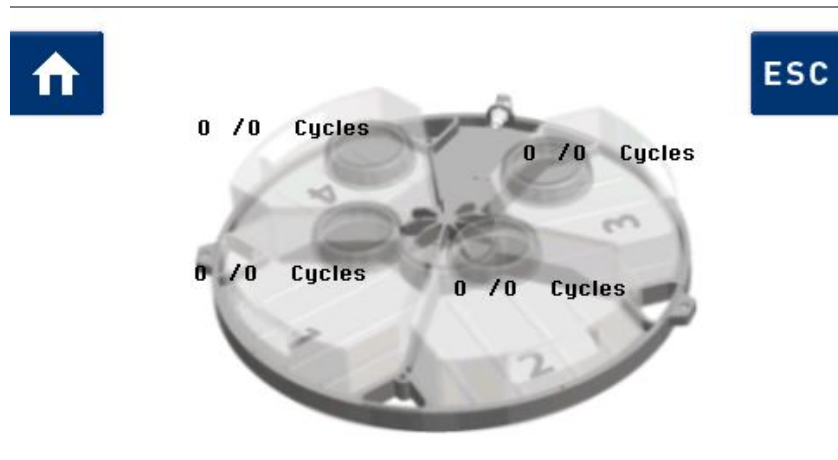

Fig. 7.1.6.3 Display *Show reminders*



As soon as a specific value is set after the forward slash, the cleaning machine - depending on the setting - counts either the cleaning cycles or the elapsed days since setting this value for the respective media tank.

**Procedure Set Reminders**

1. Using **↑** / **↓**, in the selection list (*Fig. 7.1.6.1*), select *Set reminders* and confirm with **OK**.

The *Set reminders for exchange of media* (*Fig. 7.1.6.4*) display is shown.

2. Using **←** / **→**, select between the input value and the cleaning machine *Cycles / Days* (see *Fig. 7.1.6.5*).
3. Press **+** / **-** to set the input value or to change the cleaning machine (*Cycles / Days*).
4. Press **OK** to save the settings.
5. Press **↑** or **ESC** to exit from the settings without saving.

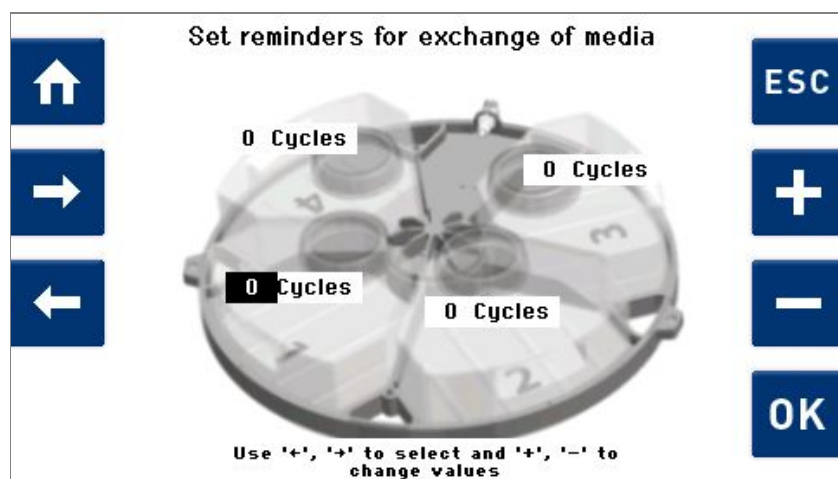
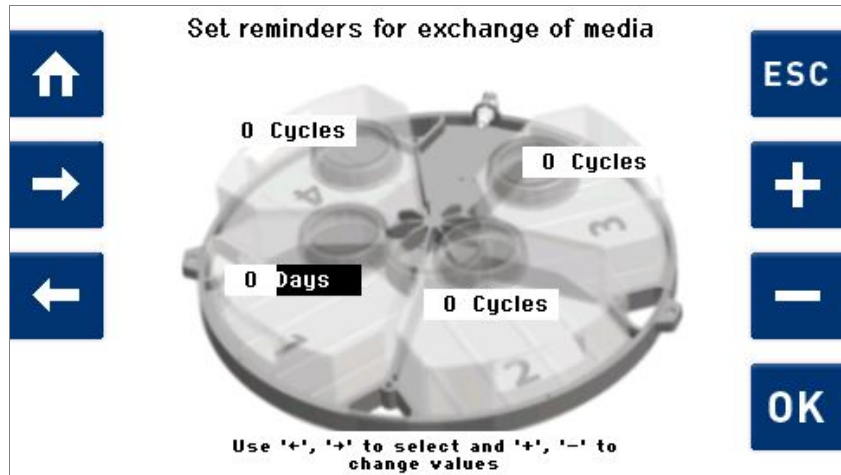

Fig. 7.1.6.4 Display *Set reminders for exchange of media*

Fig. 7.1.6.5 Display *Set Unit*

### Procedure for resetting reminders

1. Using **↑** / **↓**, in the selection list (Fig. 7.1.6.1), select *Reset reminders* and confirm with **OK**.

The *Reset reminders for exchange of media* (Fig. 7.1.6.6) display is shown.

2. Press **←** / **→** to reset the counted cycles or days individually or completely to 0.
3. Press **OK** to reset the counted cycles or days individually or completely to 0.

The counting starts again from 0.

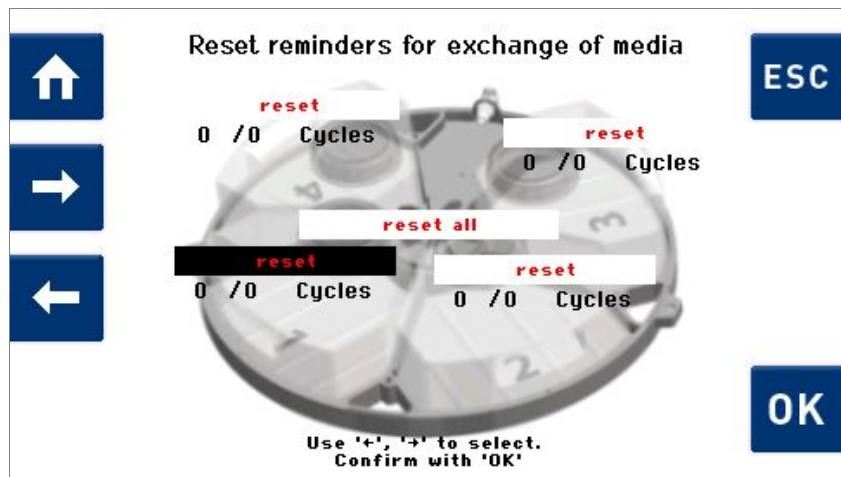
Fig. 7.1.6.6 Display *Reset reminders for exchange of media*

### Reminder for media change

If the set input value is reached, the *Change Medium!* (Fig. 7.1.6.7) display is shown after program execution. The relevant media tank is marked with a warning symbol.

Now perform the media change.

After changing the media, press **✓**.

All counted *cycles* or *days* are reset to 0.

If you would like to perform the media change at a later time, press **⏰** to be reminded again after the next program run.

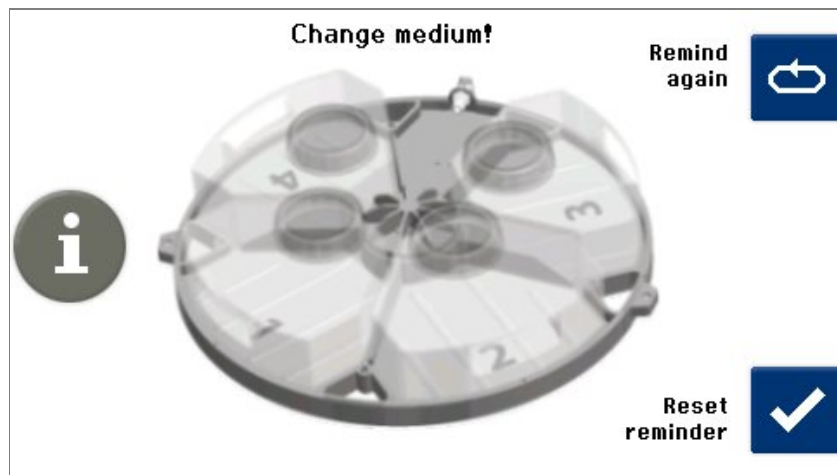

Fig. 7.1.6.7 Display *Reminder for exchange of media*

**General reminder**





**Procedure Set Reminders**

The menu item *General reminder* enables the activation of any reminder and the specification of the reminder interval.

Starting from the display *Program Selection*:

1. Press .

The display *Machine Settings* (Fig. 7.1.2) is shown.

2. Using  /  select Reminders in the selection list and confirm with .

The display *Reminders* (Fig. 7.1.6.8) is shown.

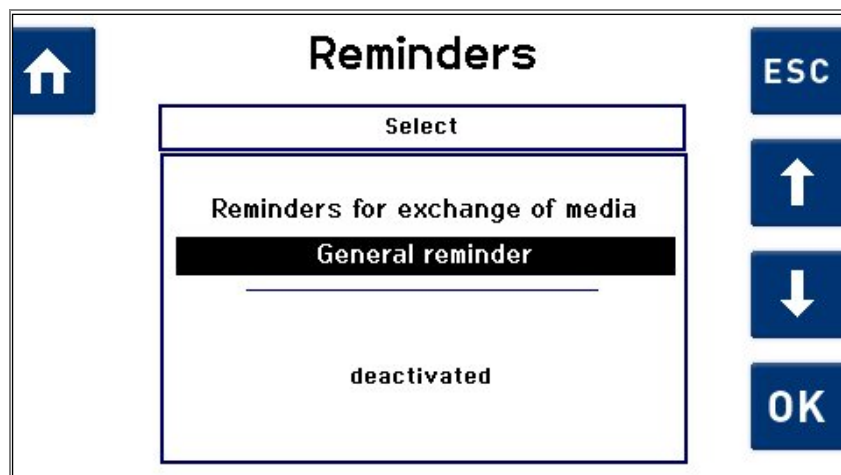





Fig. 7.1.6.8 Display *Reminders (General reminder deactivated)*

Starting from the display *Reminders*:

3. Using  /  select *General reminder* in the selection list and confirm with .

The following screen is displayed: *Assign a description to the general reminder (max. 30 characters)* Fig. 7.1.6.9

4. Navigate with  /  and  / . Select character with  to save and proceed.

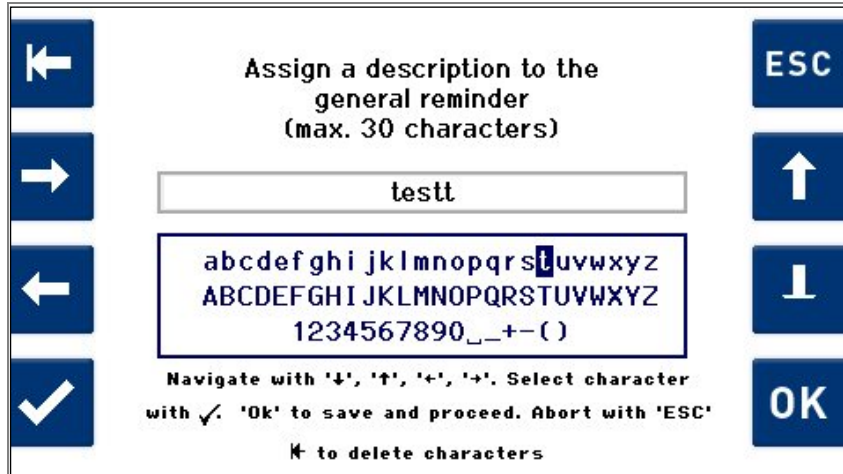
Fig. 7.1.6.9 Display description *General Reminder*

5. Press **OK** to save the settings.
6. Press **↑** or **ESC** to exit from the settings without saving.

The reminder description (example *test* Fig. 7.1.6.9) is shown in the reminder display for setting the reminder interval.

### Setting the reminder interval

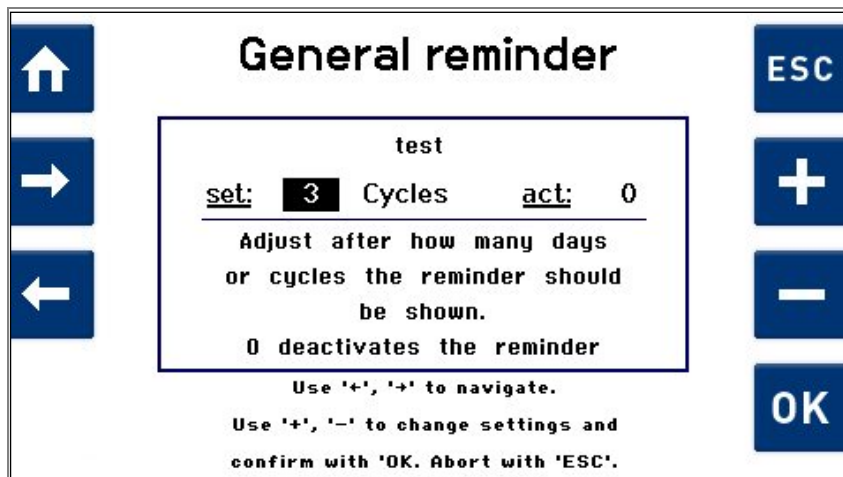

Fig. 7.1.6.10 Display for setting reminder interval

7. Using **←** / **→**, select between the input value and the cleaning machine *Cycles / Days* (see Fig. 7.1.6.10).
8. Press **+** / **-**, to adjust the input value or to change the cleaning machine (*Cycles / Days*).
9. Press **OK** to save the settings.
10. Press **↑** or **ESC** to exit from the settings without saving.

After the specified interval (*Cycles / Days*) has elapsed, the Reminder display (example *test* Fig. 7.1.6.11) is shown.

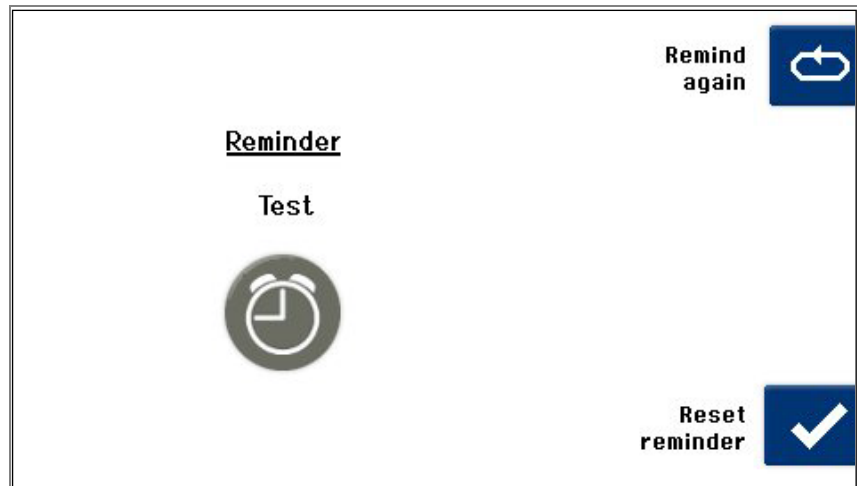

Fig. 7.1.6.11 Display *Reminder*

11. Press to be reminded again.
12. Press to reset the counted cycles / days to 0.  
The counting starts again from 0.

## 7.1.7

### Display Operating Hours



The *Operating Hours* menu item enables a view of the usage time to date of the cleaning machine and individual components.

The usage time is shown in cycles or hours and minutes.

Every component required for the cleaning process is shown separately with the respective usage time.

Only completely executed cycles are added.

**Procedure** Starting from the display *Program Select List*.

1. Press .

The display *Unit Settings* (Fig. 7.1.2) is shown.

2. Using / select *Operating Hours* in the selection list and confirm with .

The *Operating Hours* display is shown (Fig. 7.1.7.1).

3. Use / to be able to see all entries in the list.
4. Press or to exit from this display.

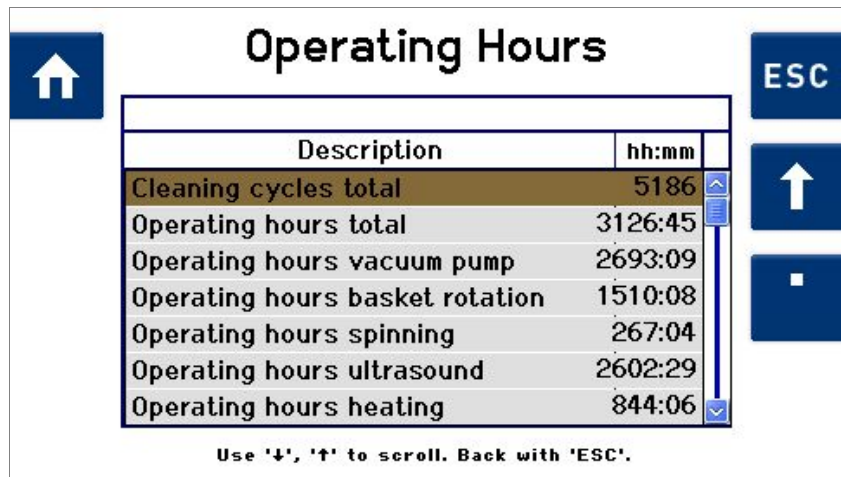

Description	hh:mm
Cleaning cycles total	5186
Operating hours total	3126:45
Operating hours vacuum pump	2693:09
Operating hours basket rotation	1510:08
Operating hours spinning	267:04
Operating hours ultrasound	2602:29
Operating hours heating	844:06

Use '↓', '↑' to scroll. Back with 'ESC'.

Fig. 7.1.7.1 Display *Operating Hours*

## 7.1.8 Setting signal tone for program end



The *Signal tone setting* menu item enables the activation of a signal tone at the end of any program run.

**Procedure** Starting from the display *Program Select List*):

1. Press

The display *Unit Settings* (Fig. 7.1.2) is shown.

2. Using / , select *Signal tone setting* in the selection list and confirm with .

The *Signal tone setting* (Fig. 7.1.8.1) display is shown.

3. Select using / whether a signal tone (*On*) or no signal tone (*Off*) should sound at the end of the cleaning program.
4. Press to confirm the input.

Press to exit from this display without changes.

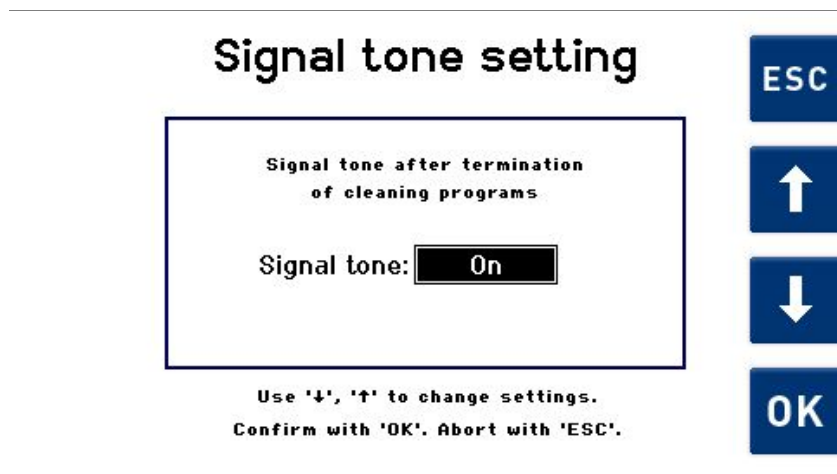

Fig. 7.1.8.1 Display *Signal tone setting*

## 7.2

## Creating your own cleaning programs

It is possible to create up to 13 additional cleaning programs of your own. There are the following options for creating cleaning programs in accordance with your own requirements:

- Create new cleaning program (*Chapter 7.2.1*).  
Recommended procedure if a program should be created with completely new parameters.
- Create new cleaning program based on a copy of an existing cleaning program (*Chapter 7.2.2*). Recommended procedure if an already existing program should be copied and also made available with a few parameter changes.
- Change existing cleaning program (*Chapter 7.2.3*).  
Recommended procedure if various parameters of an existing program should be modified.

The predefined cleaning programs stored in the cleaning machine at the factory cannot be modified or deleted.

Programs you create yourself can be copied, modified or deleted at any time.



Factory predefined cleaning programs are shown on the display with a blue background. Your own cleaning programs have a green background. The respective selected cursor field has a brown or grey background.

**Procedure** In the *Program Select List* (Fig. 7.2.1), select 



Fig. 7.2.1 Display *Program Select List*

The display (Fig. 7.2.1.1) is shown: *Modify / Create programs*.

## 7.2.1

### Create new cleaning program

Proceed starting from the display *Modify / Create Programs*.



Fig. 7.2.1.1 Display *Modify / Create Programs*

Using **↑** / **↓**, select *Create new program* in the selection list and confirm with **OK** (Fig. 7.2.1.1).

The *Enter a program name* (Fig. 7.2.1.2) display is shown.

#### Naming new program

Navigate within any line of the character selection using **←** / **→**.

Using **↑** / **↓**, you can navigate between the 3 lines.

Using the button **←**, you can delete already entered characters.

Press **✓** to apply the selected character.

To save the entered program name and continue with setting the program parameters, press **OK**.

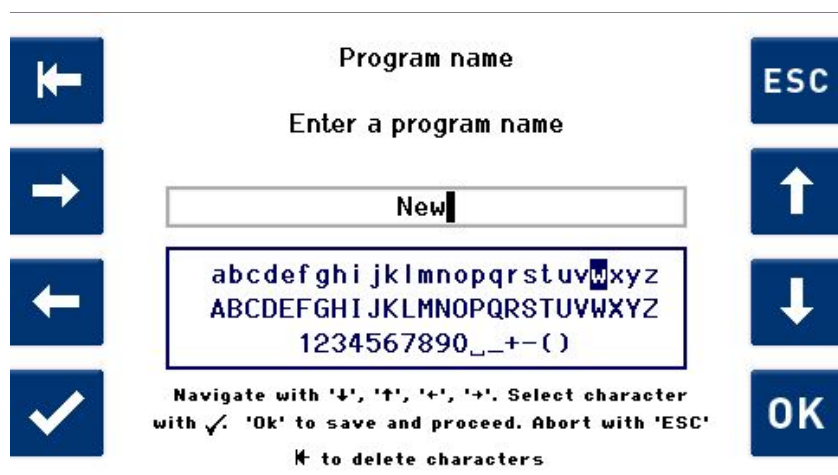

Fig. 7.2.1.2 *Enter a program name*

**Program Parameters  
Cleaning set / change**

First, the display with the program parameters from the process step *Clean* (Fig. 7.2.1.3) is shown. The already preset program parameters are based on standard cleaning processes values. You can change the preset values individually (or keep them).

Program: New  
Duration: 0:35:22h:m:s

**Clean**

Duration: 5 min: 0 sec  
Ultrasound: 40 khz 90 %  
Movement: Rotation medium  
5 rpm  
Spin: 1000 rpm 0 min: 30 sec

Rinse1

Fig. 7.2.1.3 Display Process step *Clean*

Navigate between the input fields using **←** / **→**.

Press **+** / **-** to change the preset values.

To save the settings and continue to the next process step (1st rinse step), press *Rinse 1* **→**.

The *Rinse 1* (Fig. 7.2.1.4) display is shown.

**Program Parameters  
Rinsing set / change**

For setting the *Rinse 1* process parameters, proceed in the same way as previously described for setting the *Cleaning* process parameters.



Program: New  
Duration: 0:35:22h:m:s

**Rinse1**

Duration: 2 min: 0 sec  
Ultrasound: 80 khz 90 %  
Movement: Rotation medium  
5 rpm  
Spin: 1000 rpm 0 min: 30 sec

Clean Rinse2

Fig. 7.2.1.4 Display Process step *Rinse 1*

After making the changes, press **Rinse 2**  to reach the display for the 2nd rinsing step and proceed there in the same way. Press  if you would like to return to the previous display.

Then proceed in the same way with the 3rd rinsing step and the drying step.

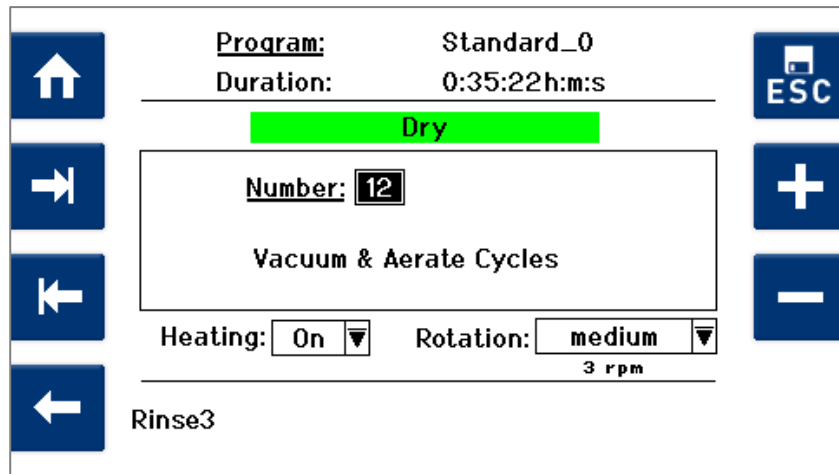





Fig. 7.2.1.4.A Process step display *Dry*

After you have changed the values of the program parameters, press  to return to the *Program Select List* display.

A query for saving the settings made is displayed first (see Fig. 7.2.1.5).



Fig. 7.2.1.5 Display *Save changes*

Using  /  select the required action from the selection list and confirm with .

Using the *Reject changes* selection, you return to the *Program Select List* display without saving the settings made.

Using the *Abort* selection, you return to the previous display.

## 7.2.2 Create cleaning program from copy

On the display *Modify / Create Programs* (Fig. 7.2.1.1), select *Create new program* using **↑** / **↓** and confirm with **OK**.

The display *New program from copy* with the already existing cleaning programs (Fig. 7.2.2.1) is shown.

### Selecting program to be modified

Using **↑** / **↓**, select the cleaning program which should be copied and modified (e.g. *Standard*).

Confirm the selection with **OK**.



Fig. 7.2.2.1 Display *new program from copy*

### Naming new program

After selection of the cleaning program to be copied, the *Program name* display (Fig. 7.2.2.2) is shown.

In the field for the program name, the original program name with a number e.g. *\_0* is initially specified. The name can be changed individually as described in *Chapter 7.2.1*.

To save the program name and continue with setting the program parameters, press **OK**.

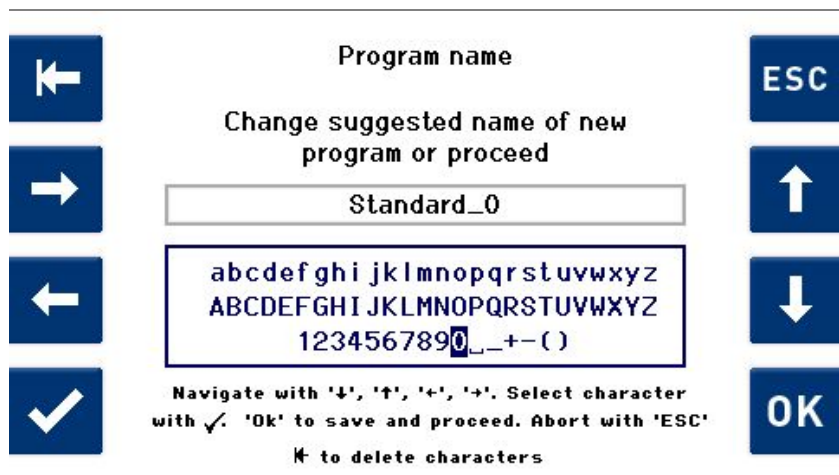

Fig. 7.2.2.2 Display *Program Name*

**Editing program parameters**

After entry of the program name, the display with the program parameters of the process step *Clean* (Fig. 7.2.1.3) is first shown.

The already existing program parameters of the copied cleaning program can now be adjusted individually.

Proceed as described in *Chapter 7.2.1*.

**7.2.3**

**Modifying existing cleaning program**



The predefined cleaning programs stored in the cleaning machine at the factory cannot be modified.

Programs you create yourself can be copied, modified or deleted at any time.

In order to change a factory predefined cleaning program, it must first be saved as a copy (*Chap. 7.2.2*).

If there is still no own cleaning program apart from the standard programs available, the message that no modifiable program has been found is shown on the display when selecting *Modify existing program*.

**Procedure**

On the display *Modify / Create Programs* (Fig. 7.2.1.1), select *Modify existing program* using **↑** / **↓** and confirm with **OK**.

The display *Modify program* with the already existing cleaning programs (Fig. 7.2.3.1) is shown.

**Selecting program to be modified**

Using **↑** / **↓**, select the cleaning program which should be *modified* (in the example *Standard\_0*) (Fig. 7.2.3.1).

Confirm the selection with **OK**.

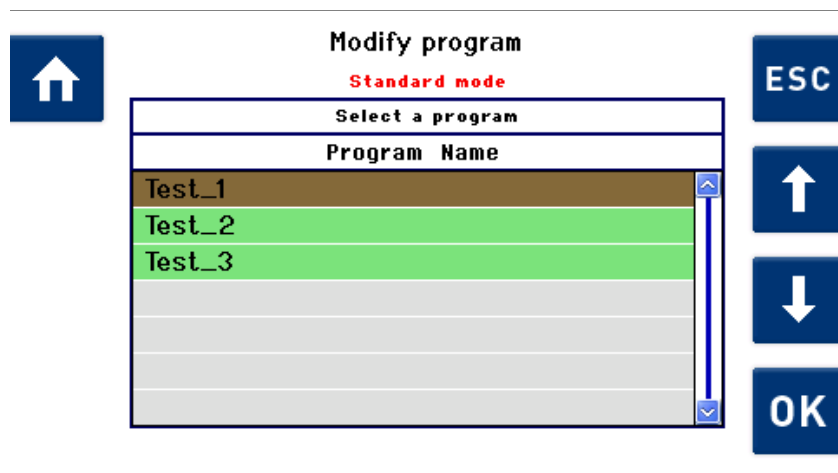

Fig. 7.2.3.1 Display *Modify Program*

**Rename program if necessary**

After selection of the cleaning program to be modified, the *Program name* display (Fig. 7.2.2.2) is shown.

The name can be changed individually or retained as described in *Chapter 7.2.1*.

To save the program name and continue with setting the program parameters, press **OK**.

**Editing program parameters**

First, the display with the program parameters from the process step *Clean* (Fig. 7.2.1.3) is shown.

The already existing program parameters of the cleaning program to be modified can now be adjusted (overwritten) individually.

**7.2.4****Delete cleaning program**

The predefined cleaning programs stored in the cleaning machine at the factory cannot be deleted.

Programs you create yourself can be deleted at any time.

**Procedure**

On the display *Modify / Create Programs* (Fig. 7.2.1.1), select *Delete existing program* using **↑** / **↓** and confirm with **OK**.

**Selecting program to be deleted**

Using **↑** / **↓**, select the cleaning program which should be deleted (in the example *Standard\_0*) (Fig. 7.2.4.1).

Confirm the selection with **OK**.

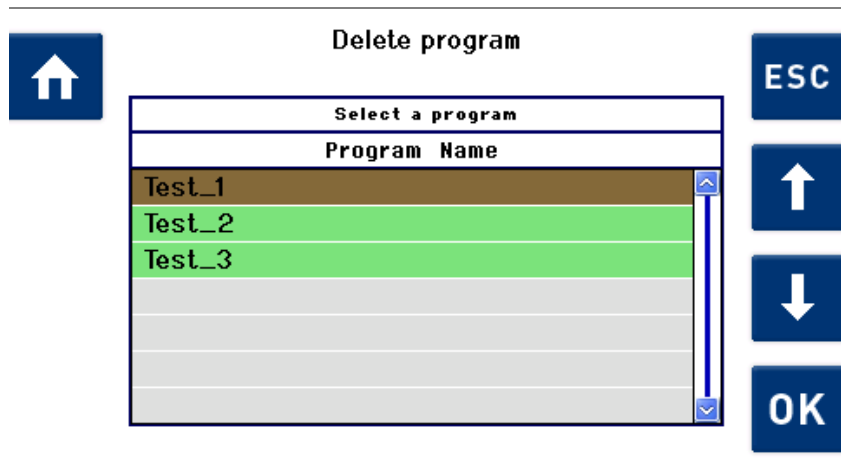

Fig. 7.2.4.1 Display *Delete program*

A display with the query whether the selected program should really be deleted is shown.

Press **OK** to confirm the "delete program" command.

Press **ESC** if the command should be discarded.

For both actions, the display *Delete program* is reached afterwards. It is possible to delete further programs or return to the *Program Select List* display **↑**.

## 8

### Media (cleaning / rinsing solutions)



Only media with flashpoint of  $\geq 12$  °C are generally permissible in the Elmasolvex<sup>®</sup>VA.

Observe the information concerning this in the safety data sheet of the medium / solvent.

In the case of doubt, contact your authorised dealer or the manufacturer.

Maximum one day's requirement of the solvents used is permitted to be stored in the surroundings of the cleaning machine at a minimum distance of 3 m from the cleaning machine.



ATTENTION

#### Observe material compatibility

When selecting cleaning and rinsing media, pay attention to their compatibility with the stainless steel (1.4301) ultrasonic bath and other stainless steel small surfaces (1.4305, 1.4310, 1.4404) and the other materials of the cleaning machine coming into contact with the media. The other plastic and elastomer materials coming into contact with the media in vapour or liquid form are:

#### Media-contacting surfaces in the cleaning machine

- Polytetrafluorethylene (PTFE)
- Polyetheretherketone (PEEK)
- Polysulphone (PSU)
- Polyphenylene sulphide (PPS)
- Polyoxymethylene (POM)
- Polypropylene (PP)
- Polyamide 12 (PA 12) for the media tanks
- Polyethylene (PE)
- Peroxide or oxygen cross-linked EPDM and NBR for static seals so that their swelling in aliphatic hydrocarbons is safe.
- FPM
- FFPM.

Also the activated carbons in the outlet filters.



ATTENTION

#### Safety instructions

Only media which are compatible in vapour or liquid form with these materials can be considered for any application.

Also observe the safety instructions (e.g. goggles, gloves, risk and safety statements) specified by the manufacturer or supplier for handling the cleaning and rinsing media used.

In the case of doubt, contact the manufacturer or supplier.

#### Exclusion of liability

Elma shall not be liable for defects for the Elmasolvex<sup>®</sup>VA cleaning machine in the case of damage caused by non-observance of the restrictions specified in *Chapter 8!*

## 8.1

### Recommended media



Elma provides suitable solvent-based cleaning ("elma wf pro"), rinsing ("elma suprol pro") and relubrication media ("elma unimix") from its own development and manufacture. Ask your dealer about these.



#### ATTENTION

The cleaning machine is always suitable for cleaning and rinsing media which are based on

1. aliphatic C8-C11 hydrocarbons  
(Exceptions: Aromatic hydrocarbons such as toluene (methylbenzene), xylene (o-, m-, or p-dimethylbenzene) and mesitylene (1,3,5-trimethylbenzene) and hydrocarbon mixtures with more than 25% content of aromatic hydrocarbons)
2. C3 or higher alkyl compounds  
(Exceptions: Of the alkoxy compounds, as well as acetone (flashpoint lower than -20 °C!) and ethyl acetate (flashpoint lower than -4 °C!), the following solvents and solvent mixtures with more than 25% content of these solvents are no longer suitable: Ethers, particularly mono, di and tripropylene glycol methyl ether (PM, DPM and TPM)
3. and meet the flashpoint limitation  $FP \geq 12 \text{ °C}$ .

The upper limit of the boiling range of rinsing media should not exceed 170 °C for successful drying (only use volatile rinsing media).

#### Instructions for the above-mentioned recommended media:

(1) The upper limit of the boiling range of rinsing media should not exceed 170 °C at normal pressure for successful drying (use sufficient volatile rinsing media at least in the last rinsing step).

(2) If the boiling range of any cleaning or rinsing medium undercuts the lower limit of 100 °C at normal pressure, the heating of the medium combined with long-lasting (> 3 minutes) ultrasound impact at full power can result in coming close to the (lower under vacuum) boiling point of such a medium.

The "Warning 211, Evacuation gradient too small" would be displayed in such a case as the required vacuum in the working chamber in the spatial area above the medium filling level would heat to > 30 °C at which the vacuum for already almost boiling media will no longer be reached quickly enough. A cooling down pause interrupting the operation of the cleaning machine or a change to medium cooled down to  $T < 30 \text{ °C}$  in the storage tank will then be required.

For example, this concerns operation of the cleaning machine with isopropyl alcohol (isopropanol, 2-propanol, IPA).

Media whose boiling range at the lower limit even undercuts 80 °C at normal pressure require media temperatures < 25 °C in the storage tank for fault-free cleaning machine operation.

## 8.2

### Technical limitations



ATTENTION

Aqueous media should not be used. Risk of cleaning machine damage!

Only solvent-based media are generally recommended for the Elmasolvex®VA cleaning machine. The cleaning machine is functionally not suitable for aqueous media, irrespective whether pH-neutral, pH-acidic or pH-alkaline.

In particular, it is not designed for foaming, aqueous cleaning media and does not have any drying suitable for parts wet with rinsing water.

Due to the filling level sensor, generally only liquid media with a relative dielectric constant (DK) of  $DK \geq 2.0$  (20 °C, 100 kHz) are permitted.

## 8.3

### Limitations for solvent-based media

#### 8.3.1

#### Flammable, solvent-based media



DANGER

Among the mostly flammable, solvent-based media, those with a flashpoint greater than or equal to 12 °C are permitted in the cleaning machine. Other media on request

Therefore, note the flashpoint specification in the safety data sheet of your intended cleaning and rinsing media.

#### 8.3.2

#### Non-flammable, solvent-based media



ATTENTION

In the case of intended permanent use with fluorinated, non-flammable solvents (e.g. epilamisation), seals made of the fluoroplastic elastomers FPM, FFPM may have to be replaced previously (see materials mentioned above).

In the case of using the cleaning machine for epilamisation with epilamisation additives / concentrates dissolved in isopropyl alcohol (isopropanol, 2-propanol, IPA), no modifications have to be made to the cleaning machine in advance.

The instructions given in *Chapter 8.1* for the lower limit of the boiling range must also be observed for cleaning machines with default settings for the user's own and standard programs also used with the media used for epilamisation and epilam coating removal.

The explosion safety requirements are not necessary in the case of exclusive use of fluorinated, non-flammable solvents.

Use with chlorinated or brominated solvents is not recommended; these require checking on request in advance and possibly the replacement of seals.

### 8.3.3 Environmental hazard from solvent-based media

#### Environmental compatibility



The cleaning and rinsing media based on hydrocarbons are not water-miscible and mostly hazardous for the environment. Also note the markings with warnings and pictograms and the information in the safety data sheet of your intended cleaning and rinsing media. This is applicable to a smaller extent for media based on alkoxy compounds.

The marking must be observed both for handling the solvent-based media as well as for their disposal.



"elma wf pro" is classified as environmentally hazardous according to R51 and R53 and therefore has an environmental hazard pictogram while "elma suprol pro" and "elma unimix" are only classified with R52 and R53 and therefore do not have any environmental hazard pictogram.

## 9 Care and maintenance tasks

The actions described in this chapter must be performed by the user.



**DANGER**

Always unplug the mains plug before care and maintenance work.

Order the required components and consumable materials from your dealer in good time.

### 9.1 Daily maintenance actions

#### 9.1.1 Filling level check of the media tanks

**Recommended interval** At least once a day (according to needs).

**Inspection criteria** Visually inspect whether the filling level of the different media tanks is in the range between the Min and Max markings (Fig. 9.1.1.1.D).

**Procedure** Adjust the filling level accordingly if required.

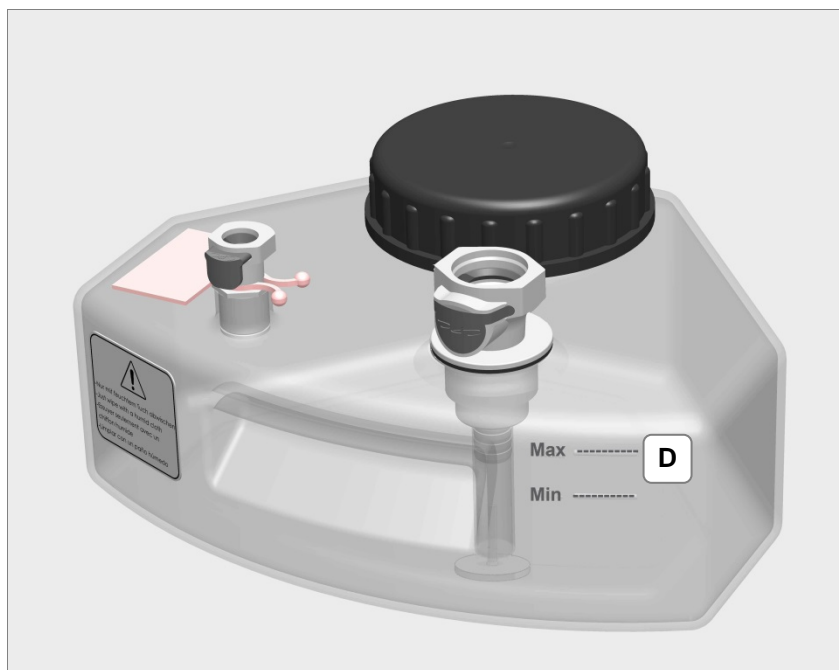

Fig. 9.1.1.1 Media tanks filling level markings

## 9.1.2 Cleaning the cleaning chamber

**Recommended interval** At least once a day (according to needs).

**Inspection criteria** Visually inspect the cleaning chamber for residues and soiling.  
In doing so, particularly check the area of the heater (Fig. 9.1.4.1.E) for adhesions.



Due to the increased surface temperatures in this area, discolouration and deposits can increasingly occur.

**Procedure** If required, clean the cleaning chamber with a cloth moistened with alcohol (e.g. IPA).

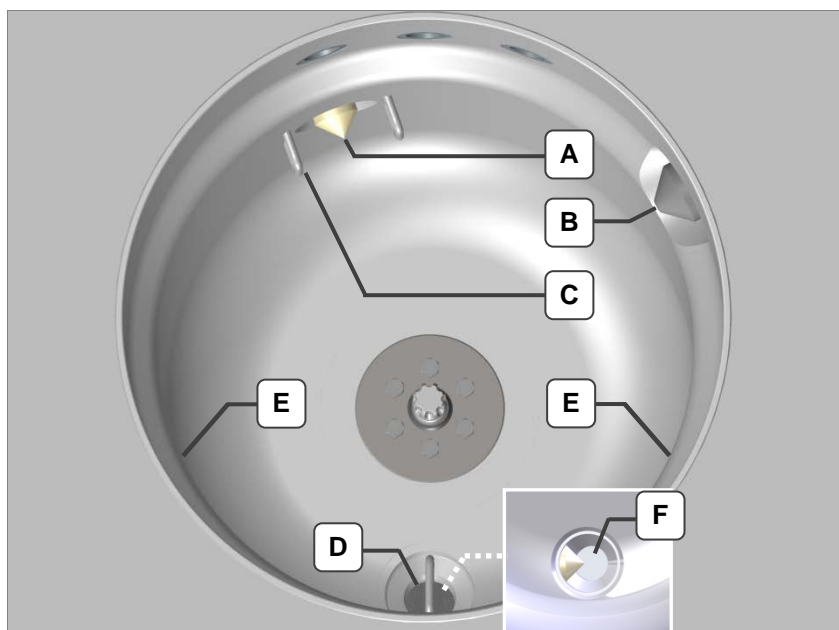



Fig.9.1.2.1 View of cleaning chamber

- A Filling level sensor** Work level
- B Filling level sensor** Overfilling level
- C Guard bar** (2 per sensor)
- D Sieve insert** (mesh size 0.36 mm) for collecting lost precision parts and coarse particles when draining the cleaning / rinsing liquid from the cleaning chamber. The sieve can be unscrewed for cleaning.  
When reinstalling the sieve, it must be screwed in carefully as far as the stop. Check freedom of movement of the cleaning basket afterwards (collision hazard if the sieve insert has not been screwed in correctly).
- E Heating areas** / radiating surfaces of the 2 heaters with radiant heat for the drying process.
- F Filling level sensor** Empty level (installed under the sieve insert).

### 9.1.3 Cleaning of the drain sieve

- Recommended interval** At least once a day (according to needs).
- Inspection criteria** Visually inspect the sieve for residues and soiling. The sieve meshes must be clean and freely permeable.
- Procedure** Unscrew the drain sieve (*Fig. 9.1.2.1.D*) anticlockwise out of the drain groove.
- Clean the sieve meshes carefully, e.g. with compressed air or a suitable brush.
- Afterwards, screw the drain sieve tightly back into the screw connection of the drain groove. Ensure that the bracket of the drain sieve does not contact the cleaning basket.
-   
**ATTENTION** Never operate the cleaning machine without sieve insert. Risk of damage in the cleaning machine!

### 9.1.4 Cleaning the filling level sensors

- Recommended interval** At least once a day (according to needs).
- Inspection criteria** Visually inspect the surfaces of the filling level sensors and the guard bar for soiling or damage (*Fig. 9.1.2.1.A/B/C/F*).
- Procedure** In the case of visible soiling, clean the components carefully with a moist cloth and a suitable cleaning agent (e.g. with your rinsing medium).
- In the case of recognisable damage to the sensors, the cleaning machine must no longer be operated. Contact the manufacturer.

### 9.1.5 Leak checks

- Recommended interval** At least once a day (according to needs).
- Inspection criteria** Leak tightness with respect to escaping media from the media-carrying tubes and couplings and the media tanks.
- Procedure** Push up the protective grilles on the right and on the left side of the cleaning machine (*Fig. 4.4.2*) and perform a visual inspection (if visible) of the specified components. Pay attention to possible media residues on the base of the cleaning machine.

## 9.2 Continuous maintenance actions

### 9.2.1 Change of cleaning and rinsing media

<b>Recommended interval</b>	After view (visual inspection of the cleaning and rinsing media in the opened media tanks) and/or in the event of diminishing cleaning result.
<b>Inspection criteria</b>	There are several possibilities available for compliance with the intervals for the media change:
<b>Reminder on the display</b>	If a service life of the media has been saved using the display, an appropriate message is shown on the display.
<b>Manual monitoring</b>	If the media in the media tanks seem to be increasingly contaminated or the cleaning parts after cleaning no longer appear to be clean, the media must be changed.
<b>Only use permitted operating materials</b>	Only permitted media (cleaning / rinsing media) are permitted to be used for safety reasons and to prevent cleaning machine damage.  Observe the instructions for recommended media and limitations for unsuitable / not permissible media ( <i>Chapter 8</i> ).



---

Fire and explosion hazard!

Observe the applicable safety regulations for handling solvents.

Keep all kinds of ignition sources away.

Prevent ignition sparks from electrostatic discharge. Discharge possible electrostatic charges (body charge) by touching any grounded equipment before handling flammable media: e.g. water tap, metal surface of the case of the cleaning machine or use ESD protective equipment (ESD arm band).

---

#### Procedure



Remove the relevant media tank from the cleaning machine.

The media tank must not be removed during running cleaning programs.

Drain the relevant media tank and clean if necessary.

Proceed as described in *Chapter 4.4* for refilling the media tanks.

Check the correct closing function of the quick couplings (*Chapter 4.4.1*) before reconnecting the media tanks.

#### Disposal of used media



Used media must be disposed of in accordance with the regulations. No disposal via the sewer system! Dispose of the used media in accordance with the national disposal regulations for the media (see safety data sheet).

## 9.2.2 Inspect media tanks, covers, suction filters

**Recommended interval** When changing the media

**Media tanks inspection criteria** Check the media tanks for leak tightness, e.g. damage such as cracks, and for not removable stubborn residues from soiling.

**Media tank cover inspection criteria** Check for damage, e.g. cracks, and the condition of the cover seal.

**Suction filter inspection criteria** Check for damage and residues from soiling.

**Media tanks, covers** Clean the components of the media tanks with a suitable cleaning agent, e.g. IPA.

**Suction filter** It is recommended to drain the media tank before removal / replacement of the suction filter.

1. Turn the quick coupling (*Fig. 9.2.2.1.C*) anticlockwise out of the media tank. The suction filter (*Fig. 9.2.2.1.G*) is now loose in the media tank.
2. Remove the suction filter, e.g. using suitable tweezers, from the media tank.

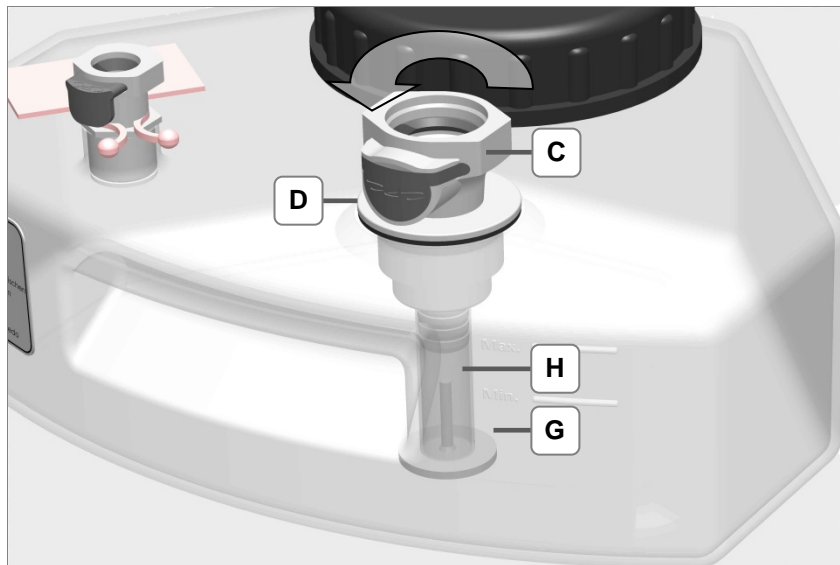
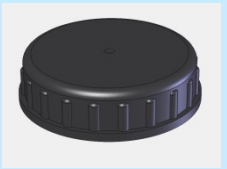
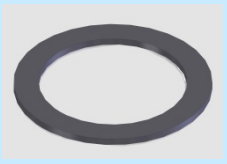



Fig. 9.2.2.1 Quick coupling and suction filter

3. Clean the filter fabric carefully using a suitable cleaning agent, e.g. IPA. Subsequent treatment with a brush or carefully with compressed air.
4. Replace the seal (D) if necessary.
5. Replace the filter on the floor of the media tank and screw in the quick coupling again. Ensure that the stem of the suction filter is located in the suction tube (*Fig. 9.2.2.1.C*) and can move freely.

Use the following article numbers for spare part orders:

Designation	Art. No.	Change interval	Illustration
Complete media tank	103 8653	Visual inspection	
Media tank	105 7126	Visual inspection	
Cover for media tank	104 4088	Visual inspection	
Coupling + tube	105 2475	Visual inspection	
Seal for coupling 105 2475	105 3131	Visual inspection	
Suction filter	105 2718	Visual inspection	
Coupling with PTFE sealing tape	105 2485	Visual inspection	

## 9.2.3 Basket holder



Particularly when using third party baskets, there is an increased risk of wear of the bottom support surfaces.

### Recommended interval

When changing the media

### Basket holder inspection criteria

The support surfaces at the bottom of the basket holder must be flat (*Fig. 9.2.3.1.A*). In the case of wear (*Fig. 9.2.3.2.B*), the basket holder must be replaced.



### ATTENTION

If the specified surfaces are worn, there is the risk that the baskets are no longer correctly fixed in the basket holder. The consequence of this is that cleaning parts can be flung out of the baskets.

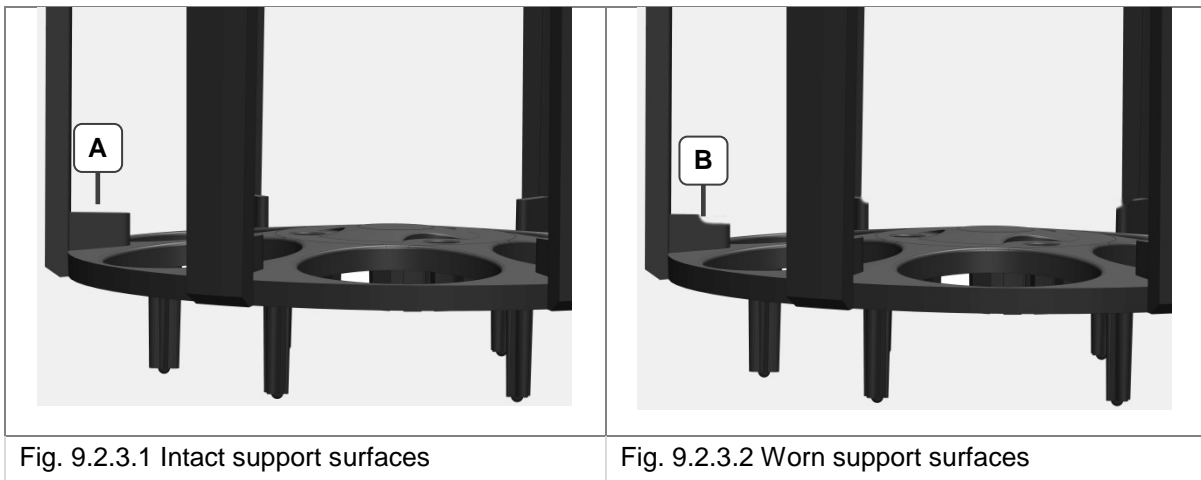

Fig. 9.2.3.1 Intact support surfaces

Fig. 9.2.3.2 Worn support surfaces

### Collar bushing inspection criteria

Check the tothing of the collar bushing (*Fig. 9.2.3.3.C*) for wear. The collar bushing must be replaced as soon as any wear on the tothing is recognisable (*Fig. 9.2.3.5.E*). Worn tothing of the collar bushing results in unbalance of the cleaning basket at higher speeds.

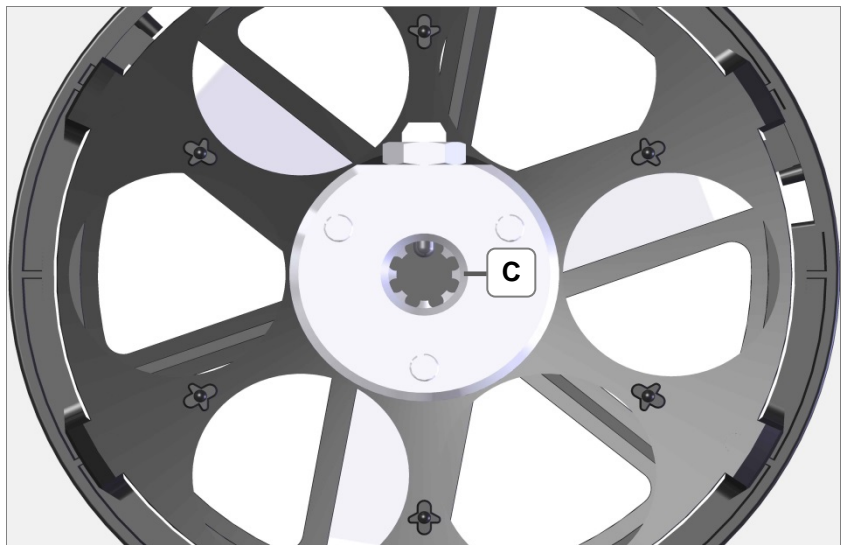
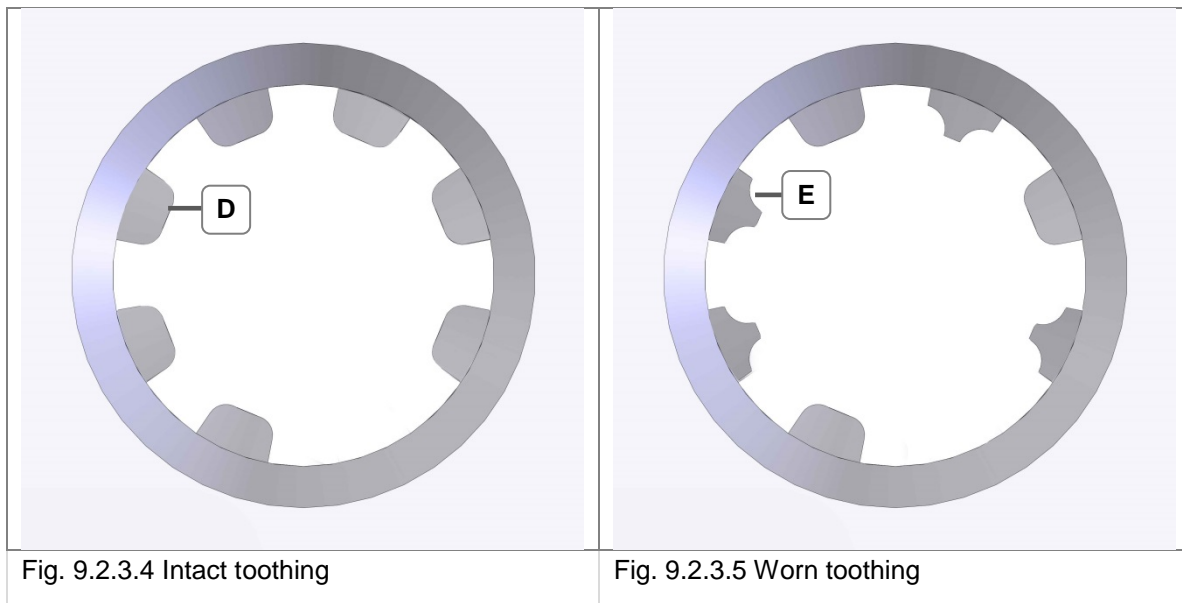



Fig. 9.2.3.3 Basket holder underside / position of the collar bushing



Use the following article numbers for spare part orders:

Designation	Art. No.	Change interval	Illustration
Basket holder, complete	105 3905	Visual inspection	
Basket holder locking	105 6436	Visual inspection	
Basket holder	104 5991	Visual inspection	
Collar bushing for basket holder, complete	106 6950	Visual inspection	

## 10 Maintenance actions / service intervals

The service intervals concern all "dynamically" loaded sealing materials, the media tanks, the activated carbon unit and parts coming into contact with the media.



The warranty is void in the case of maintenance tasks not carried out or exceeding the intervals. The manufacturer shall not accept any liability for personal injuries and property damage resulting from maintenance not having been performed.

For safety reasons, strictly replace these components within the specified intervals.

### Specified intervals

The components concerned are divided in various categories:

2-5 years service interval for components which can be replaced by the user. See *Chapter 10.1*.

5 years service interval for components which must be replaced by trained staff. See *Chapter 10.2*.

Service intervals according to the display which are performed by trained staff. See *Chapter 10.3*.

Automatic safety tests. These are performed automatically according to predefined requirements after confirming the cleaning cycle using the Start button.

- Simple safety test is performed after the cleaning machine has been disconnected from and reconnected to the mains power supply.
- Extended safety test is performed after 500 cleaning cycles, at the latest every 3 months. See *Chapter 10.4*.

### 10.1 2-5 years service interval by user

The components listed below can easily be replaced by the user himself.

Order the required components using the details shown in good time from your dealer.

Instructions for replacement of the components can be found in *Chapter 10.1.1*.

Designation	Art. No.	Use	Illustration
Seal	105 0947	Cleaning chamber cover	

## 10.1.1 Replace seal for cleaning chamber cover

### Remove sealing ring

Remove the old sealing ring from the groove using a suitable tool (e.g. pliers).  
 Attention! The inside cover (Fig. 10.1.1.1.A) is only held in the cover by the sealing ring (Fig. 10.1.1.1.B). Hold the inside cover simultaneously.

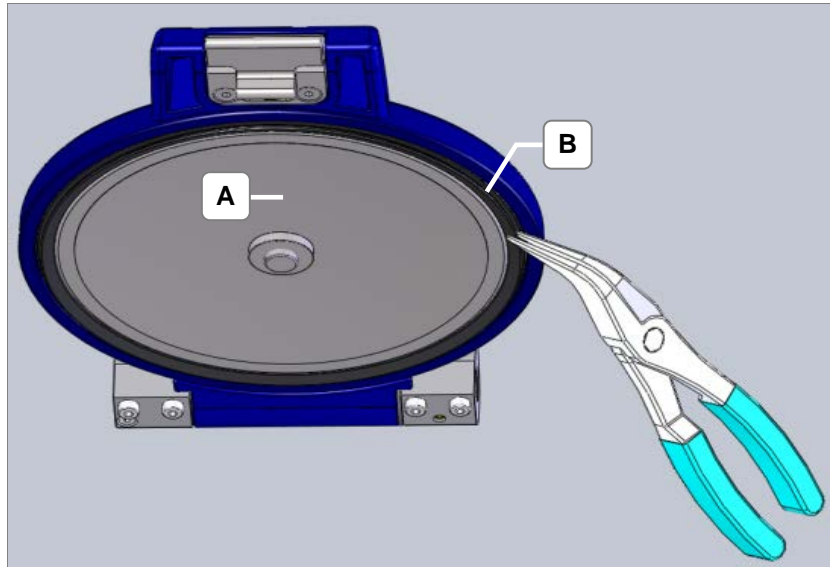

Fig. 10.1.1.1 Removing sealing ring

### Installing sealing ring

1. Place the new sealing ring around the removed inside cover.
2. Fit the inside cover with the sealing ring in the cover and press in the sealing ring evenly at 4 points (90° offset).  
 Attention! The installation position of the sealing ring and the sealing lip (C) must first be aligned as shown in Fig. 10.1.1.2.
3. Turn the sealing ring as shown in Fig. 10.1.1.3. Arrow direction until the sealing lip is aligned as shown in Fig. 10.1.1.3.C.  
 If the sealing lip is installed as shown in Fig. 10.1.1.4, turning to the installation position as shown in Fig. 10.1.1.3 is no longer possible.

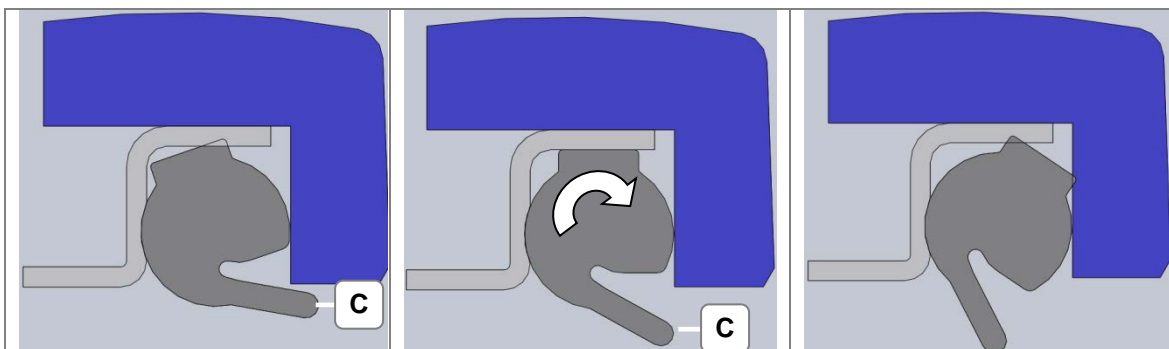

Fig. 10.1.1.2 – 1st step

Fig. 10.1.1.3 – 2nd step

Fig. 10.1.1.4 Attention!  
Incorrect!

## 10.2

### 5 years service interval by Service staff

The components shown below must only be replaced by trained staff for safety reasons.

Contact your dealer or a Service Centre authorised by the manufacturer in good time to agree the further procedure.

#### Exclusion of liability



Safe operation of the cleaning machine is no longer guaranteed. The required service must strictly be performed to continue operating the cleaning machine. The manufacturer shall not accept any liability for injuries to persons and property damage resulting from further operation.

### 10.2.1

#### Prescribed parts to be replaced (mandatory)





Designation	Art. No.	Use	Illustration
Maintenance unit, complete set as shown below			105 2474
PTFE-sinter screw connection	104 5972	PTFE-sinter screw connection, cleaning chamber	
Basket rotation mounting	105 2496	Basket rotation unit	
toothed belts	107 2985	Basket rotation unit	
Solenoid valve with connection	105 2499	Vacuum pump	
Seal	105 0947	Cleaning chamber cover	
Sealing tape	101 6143		
Silencer	105 9991	Internal output, ventilation	

Other components such as solenoid valves, vacuum pump, electric actuators, elastomer seals and media tanks must be inspected in the course of the 5-years service and replaced as required (see *Chapter 10.2.2*).

## 10.2.2

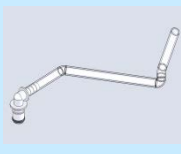
### Recommended parts to be replaced

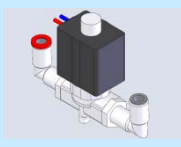
Designation	Quantity	Art. No.	Use	Illustration
Maintenance complete set as shown below	1	105 6674		
Coupling with tube	4	105 2475	Quick coupling and suction filter	
Coupling with tube Pos 1	1	105 2490	Media tank - MWV	
Coupling with tube Pos 2	1	105 2489	Media tank - MWV	
Coupling with tube Pos 3+4	2	105 2488	Media tank - MWV	
Coupling	4	104 6196	Multi-way valve	
Coupling with PTFE sealing tape	4	105 2485	Media tank	
Coupling with tube Pos 1	1	105 2481	Media tank - MWV	

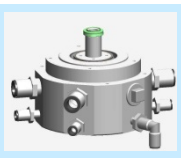
Coupling with tube Pos 2	1	105 2482	Media tank - MWV	
Coupling with tube Pos 3+4	2	105 2483	Media tank - MWV	
Quick coupling for connection of the exhaust air tube	2	103 4060	Outlet	
Coupling	4	103 8468	Multi-way valve	
Sealing tape PTFE	1	101 6143		
Connection set machine	2	107 1451	Case outlet	
Solenoid valve with fitting	1	105 2497	Step motor	
Solenoid valve with fitting	1	105 2498	Step motor	
Connection set	1	104 6955	Basket holder with collar bushing	
Multi-way valve MWV	1	1073064	Multi-way valve	

## 10.3 Service intervals according to display message

The components shown below are indicated by a corresponding notification on the display when a predefined degree of wear is reached.

### 10.3.1 Replace seal of the basket rotation unit



The seal of the basket rotation unit must be replaced after approx. 550 operating hours with speed  $n \geq 300$  rpm; however after 5 years at the latest.

This maintenance task must only be performed by trained staff. Contact the dealer which sold the cleaning machine to you to arrange carrying out the necessary maintenance.

#### Display

As soon as remaining running time of 67 operating hours is reached (corresponds to approx. 1,000 standard cleaning cycles), the following is first shown on the display: *Attention A change of the rotation seal becomes due Estimated number of standard programs remaining 1000* (Fig. 10.3.1.1).

A new and in each case one-time notification is shown when reaching remaining running time of 900, 800, 700, ...100 standard cleaning cycles.

A continuous notification is shown when reaching remaining running time of 100, 99, 98, ...1 standard cleaning cycles.

The display notification is shown after every program run as soon as the operating hours are reached / exceeded: *Warning! Contact the service. Change of the rotation seal is necessary! See operating instructions.* (Fig. 10.3.1.2). The cleaning machine must no longer be operated! The manufacturer shall not be liable!

#### Exclusion of liability



Safe operation of the cleaning machine is no longer guaranteed. The required service must strictly be performed to continue operating the cleaning machine. The manufacturer shall not accept any liability for injuries to persons and property damage resulting from further operation.

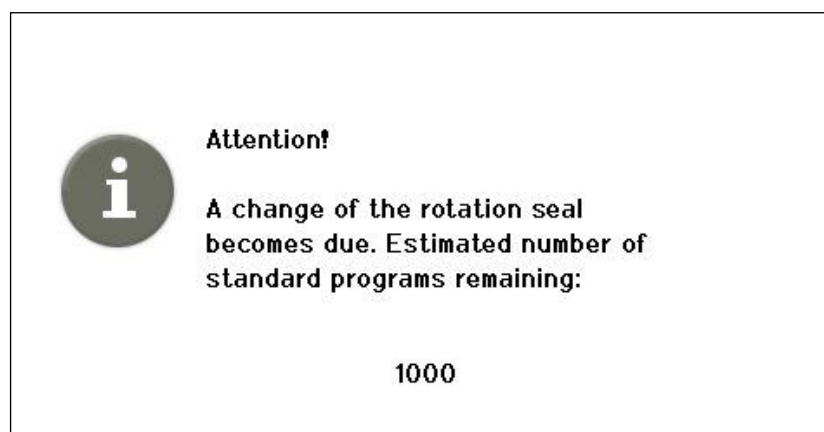

Fig. 10.3.1.1 Display *Change rotation seal*

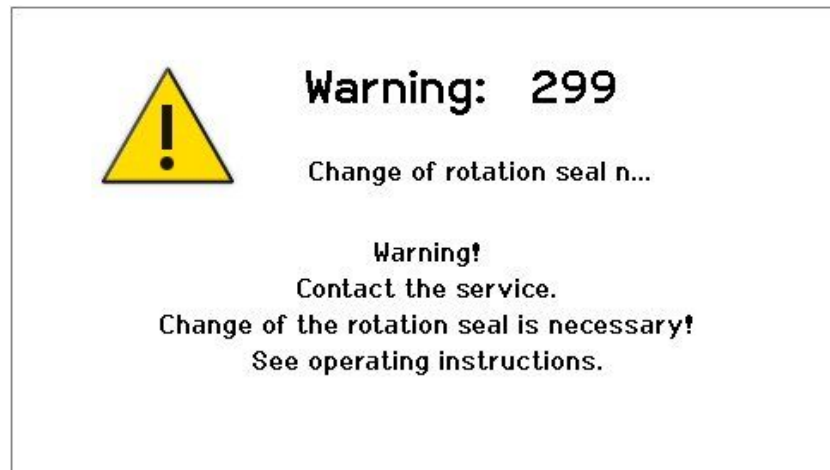

Fig. 10.3.1.2 Display *Warning: Change of rotation seal...*

## 10.4 Extended safety test

An extended safety test must be performed after every 500 cleaning cycles or at the latest every 3 months. A corresponding message is shown on the display. This must be confirmed with **OK** to start the safety test.

**i** In each case the execution of the safety test can be postponed three times with **ESC**; then the safety test must be started (*Fig. 10.4.1*). Another start of the cleaning machine is not possible again until after the extended safety test has been performed.



Fig. 10.4.1 Display *Start safety test*

For this extended safety test, the function of the *overflowing level* filling level sensor is tested by suctioning medium.

In the case of possible malfunction of the overflowing level sensor, medium can escape. This should be collected by the collecting container.

It is required here that the exhaust air tube included in the scope of delivery is connected to the ventilation connection of the cleaning chamber (Fig. 4.3.1.A). **The end of the exhaust air tube must be immersed in a collecting container ( $\geq 1.5$  litres) during this test.**

Before performing the safety test, ensure that media tank #4 is filled between the Min and Max markings.

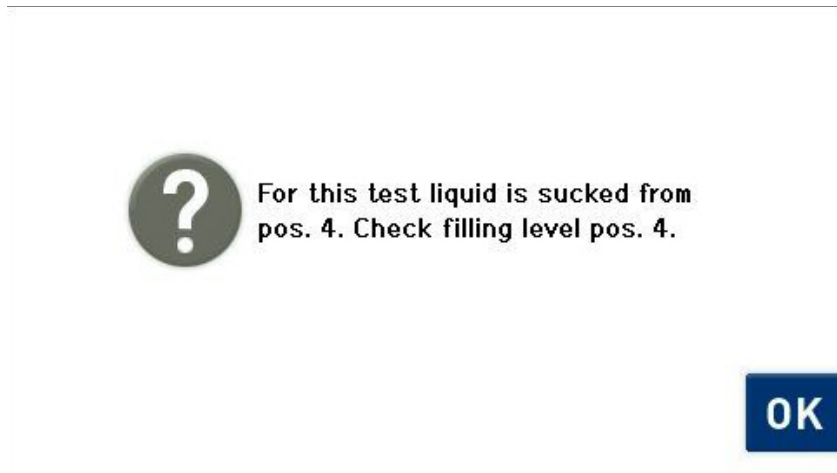

Fig. 10.4.2 Display *Check filling level pos. 4*

Confirm the correct filling level with **OK** (Fig. 10.4.2).

The safety test is now started automatically and ends after approx. 5 minutes. The progress is shown on the display (Fig. 10.4.3).

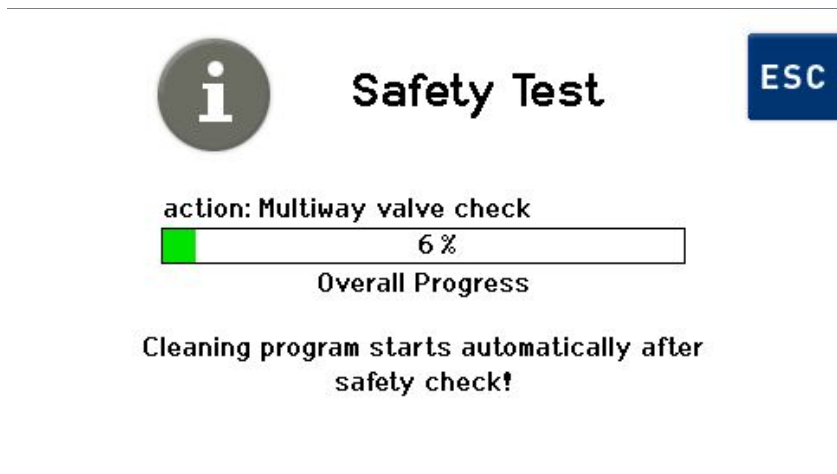

Fig. 10.4.3 Display *Safety Test progress*

# 11 Operating faults

Operating faults of the cleaning machine are mainly shown as error messages on the display.

A list of the possible error messages and the relevant procedures for fault clearance can be found in *Chapter 11.1*.

Further possible faults can be found listed in *Chapter 11.2*.

Individual actions for fault clearance which can be performed by the user can be found in *Chapter 11.3*.

If any fault cannot be rectified using the measures specified in the troubleshooting, contact the dealer or manufacturer immediately.



**DANGER**

For safety reasons, repairs must only be performed by trained staff which has been authorised by the manufacturer.

The manufacturer shall accept no liability for damage caused by unauthorised and incorrect interventions on the cleaning machine.

## 11.1

### Fault messages on the display

Possible malfunctions of the cleaning machine are shown on the display as fault messages.

In the case of operating faults where the program still runs to the end, a warning is shown on the display during the cleaning process (see *Fig. 11.1.1.A*). Pressing the operating button (see *Fig. 11.1.1.B*) displays fault information.

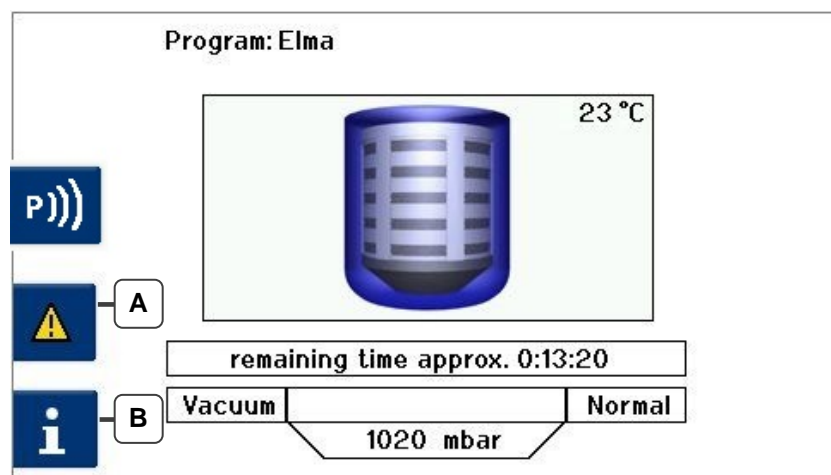















Fig. 11.1.1 Display *Fault message* (example)



Fault message	Fault description	Fault rectification
<p><b>Error No. 51 - 82</b></p>  <p>Abortion Critical fault! Explosion safety not guaranteed. Program has not been ended.</p>	<p>Tripping of the vacuum safety switch.</p> <p>Cleaning chamber too long without vacuum.</p> <p>Medium possibly drains too slowly.</p>	<p>Check the following possibilities:</p> <ul style="list-style-type: none"> <li>• Air intake and exhaust openings in the cleaning chamber (<i>Fig. 3.12.1.A</i>) clogged?</li> <li>• Condensate separator, activated carbon filter (if connected) clogged?</li> <li>• Exhaust air tube (<i>chapter 4.3</i>) kinked?</li> <li>• Sieve insert in the cleaning chamber clogged (<i>Fig.9.1.4.1</i>)?</li> <li>• Suction filter in the media tank (<i>Fig. 3.13.1.G</i>) clogged / blocked?</li> <li>• Working level fill level sensor (<i>Fig.9.1.4.1.A</i>) soiled? Clean with suitable cloth if necessary.</li> <li>• Work level fill level sensor (<i>Fig.9.1.4.1.A</i>) damaged (scratches, cracks)?</li> <li>• Quick couplings on the media tanks (<i>Fig. 3.13.1. B/C</i>) correctly engaged?</li> <li>• Can the valves of the quick couplings (<i>Fig. 4.4.1.2.J</i>) be pressed in / moved correctly?</li> <li>• Can the valves of the quick couplings on the media tanks (<i>Fig. 4.4.1.1.F</i>) be pressed in / moved correctly?</li> <li>• Is the cover of the cleaning chamber closed correctly?</li> <li>• Cover seal of the cleaning chamber (<i>chapter 10.1.1.B</i>) damaged / slipped?</li> <li>• Emergency ventilation in the cover of the cleaning chamber (<i>chapter 11.3.2.A</i>) leaking?</li> <li>• Switch off cleaning machine and restart: Contact Service if the fault persists.</li> </ul>
<p><b>Error No. 83-114</b></p>  <p>Abortion Critical fault! Cleaning chamber overfilled Program has not been ended.</p>	<p>Tripping of the overflow level fill level sensor or Fill level sensor for overflow level tripped more than three times, however only for a short time, (multiple splashes) during any process step</p>	<p>Check the following possibilities:</p> <ul style="list-style-type: none"> <li>• Cleaning basket inserted correctly?</li> <li>• Sieve insert (<i>Fig.9.1.4.1</i>) in the cleaning chamber inserted correctly?</li> <li>• Fill level in the media tank is too low (and air is drawn into the working chamber as a result)?</li> <li>• Working level fill level sensor and overflow level fill level sensor (<i>Fig.9.1.4.1 A/B</i>) soiled? Clean with suitable cloth if necessary.</li> <li>• Working level fill level sensor and overflow level fill level sensor (<i>Fig.9.1.4.1 A/B</i>) damaged (scratches, cracks)?</li> </ul>



		<ul style="list-style-type: none"> <li>• Temperature of the medium in the media tank, which the indicated partial step in the error refers to, already too high? (see temperature table for <i>Warning 211</i>).</li> </ul> <p>Remedy: use cooled down medium for the indicated process step.</p> <ul style="list-style-type: none"> <li>• Gas content in cleaning medium too high? Switch off the ultrasound and basket oscillation temporarily to degas the cleaning medium more slowly.</li> <li>• For some programs: Check deflection and frequency rate oscillation parameters.</li> <li>• Switch off cleaning machine and restart: Contact Service if the fault persists.</li> </ul>
<p>115-146</p>  <p>Warning  A fan is not functioning correctly.  Program is not ended properly. The cleaning unit cannot be restarted while the fault is present.</p>	<p>A fan is blocked or defective.</p>	<p>Check the following possibilities:</p> <ul style="list-style-type: none"> <li>• Check fans for foreign bodies and remove if necessary.</li> <li>• Switch off cleaning machine and restart: Contact Service if the fault persists.</li> </ul>
<p>147-178</p>  <p>Warning  Working level filling level not correct.</p>	<p>Fill level in cleaning chamber not optimal (or fluctuates from time to time).</p>	<p>Check the following possibilities:</p> <ul style="list-style-type: none"> <li>• Cleaning basket inserted correctly?</li> <li>• Sieve insert (<i>Fig.9.1.4.1.D</i>) in the cleaning chamber inserted correctly?</li> <li>• Fill level in the media tank is too low (and air is drawn in as a result)?</li> <li>• Working level fill level sensor and overflow level fill level sensor (<i>Fig.9.1.4.1 A/B</i>) soiled?  Clean with suitable cloth if necessary.</li> <li>• Working level fill level sensor and overflow level fill level sensor (<i>Fig.9.1.4.1 A/B</i>) damaged (scratches, cracks)?</li> <li>• Quick couplings (<i>Fig. 3.13.1. B/C</i>) engaged?</li> <li>• Flat seal in quick coupling (<i>Fig. 4.4.1.4</i>) damaged?</li> <li>• Gas content in cleaning medium too high? Switch off the ultrasound and basket oscillation temporarily to degas the cleaning medium.</li> <li>• Switch off cleaning machine and restart: Contact Service if the fault persists.</li> </ul>



<p>179</p>  <p>Warning The temperature in the chamber is too high! The cleaning is aborted when 45 °C is reached.</p>	<p>Media temperature in the cleaning chamber too high (<math>\geq 40 \text{ °C} &lt; 45 \text{ °C}</math>) in the indicated step of the cleaning process.</p>	<p>Check the following possibilities:</p> <ul style="list-style-type: none"> <li>• Ambient temperature must be <math>&lt; 30 \text{ °C}</math>.</li> <li>• Measure temperature of the medium in the media tank referred to in the partial step indicated in Warning 211. Boiling range lower   Permitted limit of the medium<sup>*)</sup>   Media Temp <math>T_s &gt; 100 \text{ °C}</math>   <math>T &lt; 45 \text{ °C}</math> <sup>*)</sup> According to safety data sheet.</li> <li>• Cleaning cycles are started at too short intervals</li> <li>• Media heating due to too long-lasting ultrasound impact.</li> <li>• Let cleaning machine cool down and restart: Contact Service if the fault persists.</li> </ul>
<p>180</p>  <p>Program is aborted due to overtemperature (<math>&gt; 45 \text{ °C}</math>)! Wait until the process is ended.</p>	<p>Media temperature in the cleaning chamber too high (<math>&gt; 45 \text{ °C}</math>).</p>	<p>Check the following possibilities:</p> <ul style="list-style-type: none"> <li>• Ventilation slots blocked?</li> <li>• Ambient temperature must be <math>&lt; 30 \text{ °C}</math>.</li> <li>• Media temperature and media heating – see <i>warnings 179 and 211</i>.</li> <li>• Let cleaning machine cool down and restart: Contact Service if the fault persists.</li> </ul>
<p>181</p>  <p>Warning! Small temperature change during the heating process</p>	<p>Temperature measurement defective, the measured temperature does not change as intended during the heating up (e.g. temperature sensor has detached itself from the cleaning chamber, heaters are defective).</p>	<p>Check the following possibilities:</p> <ul style="list-style-type: none"> <li>• Switch off cleaning machine and restart: Contact Service if the fault persists.</li> </ul>
<p>201</p>  <p>Abortion Critical fault! MWV drive defective. Program has not been ended.</p>	<p>Multi-way valve does not reach position / overshoots position / may be stiff.</p>	<p>Check the following possibilities:</p> <p>First, place collecting container (<math>\geq 1.5</math> litres) at the bottom case outlet (<i>Fig.4.3.1.B</i>)</p> <ul style="list-style-type: none"> <li>• Disconnect cleaning machine from mains power supply and restart.</li> <li>• In the event of liquid discharge from the bottom case outlet: For further procedure, see point <i>Liquid discharge from bottom case opening (chapter 11.2)</i> Clean deflagration protection (<i>chapter. 11.3.1</i>)</li> <li>• Disconnect cleaning machine from the mains power supply</li> </ul>



		<ul style="list-style-type: none"> <li>• Correct media tanks fill levels</li> <li>• Switch off cleaning machine and restart: Contact Service if the fault persists.</li> </ul>
<p>202</p>  <p>Abortion                  Critical fault!                  Pressure measurement defective.                  Program has not been ended.</p>	<p>Pressure measurement failure:                  Sensor or electronics fault.</p>	<p>Check the following possibilities:</p> <ul style="list-style-type: none"> <li>• Switch off cleaning machine and restart: Contact Service if the fault persists.</li> </ul>
<p>203</p>  <p>Abortion                  Critical fault!                  Temperature measurement defective.                  Program has not been ended.</p>	<p>Temperature measurement failure.</p>	<p>Check the following possibilities:</p> <ul style="list-style-type: none"> <li>• Switch off cleaning machine and restart: Contact Service if the fault persists.</li> </ul>
<p>204</p>  <p>Abortion                  Critical fault!                  Overfilling level filling level sensor defective.                  Program has not been ended.</p>	<p>Plausibility error (working level fill level sensor, overflow level fill level sensor).</p>	<p>Check the following possibilities:</p> <ul style="list-style-type: none"> <li>• Working level fill level sensor (<i>Fig.9.1.4.1.B</i>) soiled?                      Clean with suitable cloth if necessary.</li> <li>• Work level fill level sensor (<i>Fig.9.1.4.1.B</i>) damaged (scratches, cracks)?</li> <li>• Switch off cleaning machine and restart: Contact Service if the fault persists.</li> </ul>
<p>205</p>  <p>Abortion                  Both fans are defective or blocked!                  Program has not been ended.</p>	<p>Failure of both fans.</p>	<p>Check the following possibilities:</p> <ul style="list-style-type: none"> <li>• Check fans for foreign bodies and remove if necessary</li> <li>• Switch off cleaning machine and restart: Contact Service if the fault persists.</li> </ul>





<p>211</p>  <p>Warning Evacuation gradient too low.</p>	<p>Vacuum in the working chamber is reached too slowly in the indicated step of the cleaning process.</p>	<p>Check the following possibilities:</p> <ul style="list-style-type: none"> <li>• Is the cover of the cleaning chamber closed correctly?</li> <li>• Cover seal of the cleaning chamber (<i>chapter 10.1.1.B</i>) damaged / slipped?</li> <li>• Emergency ventilation in the cover of the cleaning chamber (<i>chapter 11.3.2.A</i>) leaking?</li> <li>• Measure temperature of the medium in the media tank referred to in the partial step indicated in Warning 211. Boiling range lower   Permitted limit of the medium<sup>*)</sup>   Media Temp  <math>T_s &gt; 100\text{ °C}</math>   <math>T &lt; 45\text{ °C}</math>  <math>80 &lt; T_s &lt; 100\text{ °C}</math>   <math>T &lt; 30\text{ °C}</math>  <math>70 &lt; T_s &lt; 80\text{ °C}</math>   <math>T &lt; 25\text{ °C}</math>  <sup>*)</sup> According to safety data sheet.</li> <li>• Condensate separator, activated carbon filter (if connected) clogged?</li> <li>• Exhaust air tube (<i>chapter 4.3</i>) kinked?</li> <li>• Are the quick couplings on the media tanks (<i>Fig. 3.13.1. B/C</i>) correctly engaged?</li> <li>• Switch off cleaning machine and restart: Contact Service if the fault persists.</li> </ul>
<p>212</p>  <p>Abortion Evacuation gradient too low. Explosion safety not guaranteed. Program has not been ended.</p>	<p>Timeout, vacuum is not achieved. Possible cause: Cleaning / rinsing: Temperature of the medium (see Error 211). Drying: Scooping parts with larger quantity of last rinsing medium not draining (see cause for 211).</p>	<p>Check the following possibilities:</p> <ul style="list-style-type: none"> <li>• Is the cover of the cleaning chamber closed correctly?</li> <li>• Cover seal of the cleaning chamber (<i>chapter 10.1.1.B</i>) damaged / slipped?</li> <li>• Emergency ventilation in the cover of the cleaning chamber (<i>chapter 11.3.2.A</i>) leaking?</li> <li>• Measure temperature of the medium in the media tank (see <i>Error 211</i>)</li> <li>• Avoid scooping arrangement of parts – position parts in the basket favourably for draining.</li> <li>• Condensate separator, activated carbon filter (if connected) clogged?</li> <li>• Exhaust air tube (<i>chapter 4.3</i>) kinked?</li> <li>• Air intake and exhaust openings in the cleaning chamber (<i>Fig. 3.12.1.A</i>) clogged?</li> <li>• Quick couplings on the media tanks (<i>Fig. 3.13.1. B/C</i>) correctly engaged?</li> <li>• Switch off cleaning machine and restart: Contact Service if the fault persists.</li> </ul>





<p>213</p>  <p>Abortion          Error!          No filling from position 3 (example).</p>	<p>Cleaning chamber cannot be filled.          Possibly no vacuum is produced.</p>	<p>Check the following possibilities:</p> <ul style="list-style-type: none"> <li>• Is the cover of the cleaning chamber closed correctly?</li> <li>• Cover seal of the cleaning chamber (<i>chapter 10.1.1.B</i>) damaged / slipped?</li> <li>• Emergency ventilation in the cover of the cleaning chamber (<i>chapter 11.3.2.A</i>) leaking?</li> <li>• Air intake and exhaust openings in the cleaning chamber (<i>Fig. 3.12.1.A</i>) clogged?</li> <li>• Condensate separator, activated carbon filter (if connected) clogged?</li> <li>• Exhaust air tube (<i>chapter 4.3</i>) kinked?</li> <li>• Sieve insert (<i>Fig.9.1.4.1</i>) in the cleaning chamber clogged?</li> <li>• Fill level in the media tank too low?</li> <li>• Can the valves of the quick couplings (<i>Fig. 4.4.1.2.J</i>) be pressed in / moved correctly?</li> <li>• Can the valves of the quick couplings on the media tanks (<i>Fig. 4.4.1.1.F</i>) be pressed in / moved correctly?</li> <li>• Are the quick couplings on the media tanks (<i>Fig. 3.13.1. B/C</i>) correctly engaged?</li> <li>• Suction filter in the media tank (<i>Fig. 3.13.1.G</i>) clogged / blocked?</li> <li>• Fill level sensor <i>Empty level</i> (<i>Fig.9.1.4.1.F</i>) soiled? Clean with suitable cloth if necessary.</li> <li>• Fill level sensor <i>Empty level</i> (<i>Fig.9.1.4.1.F</i>) damaged (scratches, cracks)?</li> <li>• Switch off cleaning machine and restart: Contact Service if the fault persists.</li> </ul>
<p>214</p>  <p>Abortion          Error!          Cleaning chamber is not filled          Check media tank filling level, tubes etc.          Program has not been ended.</p>	<p>Timeout during filling of the cleaning chamber: Timeout of the working level fill level sensor.</p>	<p>Check the following possibilities:</p> <ul style="list-style-type: none"> <li>• Is the cover of the cleaning chamber closed correctly?</li> <li>• Cover seal of the cleaning chamber (<i>chapter 10.1.1.B</i>) damaged / slipped?</li> <li>• Emergency ventilation in the cover of the cleaning chamber (<i>chapter 11.3.2.A</i>) leaking?</li> <li>• Condensate separator, activated carbon filter (if connected) clogged?</li> <li>• Exhaust air tube (<i>chapter 4.3</i>) kinked?</li> <li>• Air intake and exhaust openings in the cleaning chamber (<i>Fig. 3.12.1.A</i>) clogged?</li> </ul>







		<ul style="list-style-type: none"> <li>• Sieve insert in the cleaning chamber clogged (<i>Fig.9.1.4.1</i>)?</li> <li>• Fill level in the media tank is too low</li> <li>• Can the valves of the quick couplings (<i>Fig. 4.4.1.2.J</i>) be pressed in / moved correctly?</li> <li>• Can the valves of the quick couplings on the media tanks (<i>Fig. 4.4.1.1.F</i>) be pressed in / moved correctly?</li> <li>• Are the quick couplings on the media tanks (<i>Fig. 3.13.1. B/C</i>) correctly engaged?</li> <li>• Suction filter in the media tank (<i>Fig. 3.13.1.G</i>) clogged / blocked?</li> <li>• Filling level sensor <i>Empty level</i> (installed under the sieve insert)(<i>Fig.9.1.4.1.F</i>) soiled? Clean with suitable cloth if necessary.</li> <li>• Fill level sensor <i>Empty level</i> (<i>Fig.9.1.4.1.F</i>) damaged (scratches, cracks)?</li> <li>• Switch off cleaning machine and restart: Contact Service if the fault persists.</li> </ul>
<p>215</p>  <p>Abortion Critical fault! Venting not possible. Program has not been ended.</p>	<p>Vacuum in the cleaning chamber is not released.</p>	<p>Check the following possibilities:</p> <ul style="list-style-type: none"> <li>• Air intake and exhaust openings in the cleaning chamber (<i>Fig. 3.12.1.A</i>) clogged?</li> <li>• Exhaust air tube (<i>chapter 4.3</i>) kinked?</li> <li>• Switch off cleaning machine and restart: Contact Service if the fault persists.</li> </ul>
<p>216</p>  <p>Cleaning chamber drains slowly.</p>	<p>Timeout 1 of the <i>Empty level</i> fill level sensor during draining of the cleaning chamber.</p>	<p>Check the following possibilities:</p> <ul style="list-style-type: none"> <li>• Condensate separator, activated carbon filter (if connected) clogged?</li> <li>• Exhaust air tube (<i>chapter 4.3</i>) kinked?</li> <li>• Air intake and exhaust openings in the cleaning chamber (<i>Fig. 3.12.1.A</i>) clogged?</li> <li>• Sieve insert in the cleaning chamber clogged (<i>Fig.9.1.4.1</i>)?</li> <li>• Fill level in the media tank is too high</li> <li>• Can the valves of the quick couplings (<i>Fig. 4.4.1.2.J</i>) be pressed in / moved correctly?</li> <li>• Can the valves of the quick couplings on the media tanks (<i>Fig. 4.4.1.1.F</i>) be pressed in / moved correctly?</li> <li>• Are the quick couplings on the media tanks (<i>Fig. 3.13.1. B/C</i>) correctly engaged?</li> </ul>



		<ul style="list-style-type: none"> <li>• Suction filter in the media tank (<i>Fig. 3.13.1.G</i>) clogged / blocked?</li> <li>• Switch off cleaning machine and restart: Contact Service if the fault persists.</li> </ul>
<p>217</p> <p></p> <p>Abortion          Error!          Cleaning chamber drains too slowly.          Wait, then remove and clean sieve insert.</p>	<p>Timeout 2 of the <i>Empty level</i> fill level sensor during draining.</p>	<p>Check the following possibilities:</p> <ul style="list-style-type: none"> <li>• Condensate separator, activated carbon filter (if connected) clogged?</li> <li>• Exhaust air tube (<i>chapter 4.3</i>) kinked?</li> <li>• Air intake and exhaust openings in the cleaning chamber (<i>Fig. 3.12.1.A</i>) clogged?</li> <li>• Sieve insert in the cleaning chamber clogged (<i>Fig.9.1.4.1</i>)?</li> <li>• Can the valves of the quick couplings (<i>Fig. 4.4.1.2.J</i>) be pressed in / moved correctly?</li> <li>• Can the valves of the quick couplings on the media tanks (<i>Fig. 4.4.1.1.F</i>) be pressed in / moved correctly?</li> <li>• Are the quick couplings on the media tanks (<i>Fig. 3.13.1. B/C</i>) correctly engaged?</li> <li>• Suction filter in the media tank (<i>Fig. 3.13.1.G</i>) clogged / blocked?</li> <li>• Filling level sensor <i>Empty level</i> (installed under the sieve insert) (<i>Fig.9.1.4.1.F</i>) soiled? Clean with suitable cloth if necessary.</li> <li>• Fill level sensor <i>Empty level</i> (<i>Fig.9.1.4.1.F</i>) damaged (scratches, cracks)?</li> <li>• Retrofit ant-reflection sleeve for <i>Empty level</i> fill level sensor.</li> <li>• Switch off cleaning machine and restart: Contact Service if the fault persists.</li> </ul>
<p>218</p> <p></p> <p>Abortion          Error!          Cleaning chamber does not drain.</p>	<p>Timeout of the working level fill level sensor during draining of the cleaning chamber.</p>	<p>Check the following possibilities:</p> <ul style="list-style-type: none"> <li>• Condensate separator, activated carbon filter (if connected) clogged?</li> <li>• Exhaust air tube (<i>chapter 4.3</i>) kinked?</li> <li>• Air intake and exhaust openings in the cleaning chamber (<i>Fig. 3.12.1.A</i>) clogged?</li> <li>• Sieve insert in the cleaning chamber clogged (<i>Fig.9.1.4.1</i>)?</li> <li>• Fill level in the media tank overfilled?</li> <li>• Can the valves of the quick couplings (<i>Fig. 4.4.1.2.J</i>) be pressed in / moved correctly?</li> </ul>

		<ul style="list-style-type: none"> <li>• Can the valves of the quick couplings on the media tanks (<i>Fig. 4.4.1.1.F</i>) be pressed in / moved correctly?</li> <li>• Quick couplings on the media tanks (<i>Fig. 3.13.1. B/C</i>) correctly engaged?</li> <li>• Suction filter in the media tank (<i>Fig. 3.13.1.G</i>) clogged / blocked?</li> <li>• Switch off cleaning machine and restart: Contact Service if the fault persists.</li> </ul>
<p>220 – 234</p>  <p>Abortion Critical fault! MWV drive defective.</p>	<p>Failure of multi-way valve rotary encoder.</p>	<p>Check the following possibilities: First, place collecting container (<math>\geq 1.5</math> litres) at the bottom case outlet</p> <ul style="list-style-type: none"> <li>• In the event of liquid discharge from the bottom case opening: See <i>chapter 11.2</i> for the further procedure. <i>Liquid discharge from the bottom case opening</i></li> </ul> <p>Clean deflagration protection (<i>chapter. 11.3.1</i>)</p> <ul style="list-style-type: none"> <li>• Correct media tanks fill levels</li> <li>• Disconnect cleaning machine from mains power supply and restart. Contact Service if the fault persists.</li> </ul>
<p>253</p>  <p>Critical error! Vacuum safety switch faulty. Safety test not finished. See operating instructions.</p>	<p>Vacuum safety switch does not trip during extended safety test.</p>	<p>Check the following possibilities:</p> <ul style="list-style-type: none"> <li>• Switch off cleaning machine and restart: Contact Service if the fault persists.</li> </ul>
<p>254</p>  <p>Critical error! Filling level sensor for overfilling faulty. Safety test not finished. See operating instructions.</p>	<p>Fill level sensor <i>Overfill level</i> does not trip during extended safety test.</p>	<p>Check the following possibilities:</p> <ul style="list-style-type: none"> <li>• Switch off cleaning machine and restart: Contact Service if the fault persists.</li> </ul>

<p>263</p>  <p>Critical error!        Multiway valve drive faulty.        Safety test not finished.        See operating instructions.</p>	<p>MWV (multi-way valve) drive defective and/or communication error during safety test.</p>	<p>Check the following possibilities:</p> <ul style="list-style-type: none"> <li>• Switch off cleaning machine and restart: Contact Service if the fault persists.</li> </ul>
<p>264</p>  <p>Critical error!        Vacuum safety switch faulty.        Safety test not finished.        See operating instructions.</p>	<p>Vacuum safety switch malfunction during safety test.</p>	<p>Check the following possibilities:</p> <ul style="list-style-type: none"> <li>• Switch off cleaning machine and restart: Contact Service if the fault persists.</li> </ul>
<p>265</p>  <p>Abortion        Critical fault!        Overfilling level filling level sensor defective.</p>	<p>Malfunction of the overfill level fill level sensor during the safety test.</p>	<p>Check the following possibilities:</p> <ul style="list-style-type: none"> <li>• Overfill level fill level sensor (Fig.9.1.4.1.A/B) soiled? Clean with suitable cloth if necessary.</li> <li>• Overfill fill level sensor (Fig.9.1.4.1.A/B) damaged (scratches, cracks)?</li> <li>• Switch off cleaning machine and restart: Contact Service if the fault persists.</li> </ul>
<p>266</p>  <p>Abortion        Critical fault!        Level empty filling level sensor defective.</p>	<p>Malfunction of the <i>Empty level</i> fill level sensor during the safety test.</p>	<p>Check the following possibilities:</p> <ul style="list-style-type: none"> <li>• Cleaning chamber empty (correct)?</li> <li>• Filling level sensor <i>Empty level</i> (installed under the sieve insert) (Fig.9.1.4.1.F) soiled? Clean with suitable cloth if necessary.</li> <li>• Fill level sensor <i>Empty level</i> (Fig.9.1.4.1.F) damaged (scratches, cracks)?</li> <li>• Retrofit ant-reflection sleeve for <i>Empty level</i> fill level sensor.</li> <li>• Switch off cleaning machine and restart: Contact Service if the fault persists.</li> </ul>

<p>267</p>  <p>Abortion Critical fault! Working level filling level sensor defective.</p>	<p>Malfunction of the <i>Working level</i>/fill level sensor during the safety test.</p>	<p>Check the following possibilities:</p> <ul style="list-style-type: none"> <li>• Cleaning chamber empty (correct)?</li> <li>• Working level fill level sensor (<i>Fig.9.1.4.1.A</i>) soiled? Clean with suitable cloth if necessary.</li> <li>• Work level fill level sensor (<i>Fig.9.1.4.1.A</i>) damaged (scratches, cracks)?</li> <li>• Switch off cleaning machine and restart: Contact Service if the fault persists.</li> </ul>
<p>268</p>  <p>Abortion Critical fault! Vacuum is not achieved.</p>	<p>Vacuum cannot be achieved during the safety test.</p>	<p>Check the following possibilities:</p> <ul style="list-style-type: none"> <li>• Is the cover of the cleaning chamber closed correctly?</li> <li>• Cover seal of the cleaning chamber (<i>chapter 10.1.1.B</i>) damaged / slipped?</li> <li>• Emergency ventilation in the cover of the cleaning chamber (<i>chapter 11.3.2.A</i>) leaking?</li> <li>• Condensate separator, activated carbon filter (if connected) clogged?</li> <li>• Exhaust air tube (<i>chapter 4.3</i>) kinked?</li> <li>• Can the valves of the quick couplings (<i>Fig. 4.4.1.2.J</i>) be pressed in / moved correctly?</li> <li>• Can the valves of the quick couplings on the media tanks (<i>Fig. 4.4.1.1.F</i>) be pressed in / moved correctly?</li> <li>• Are the quick couplings on the media tanks (<i>Fig. 3.13.1. B/C</i>) correctly engaged?</li> <li>• Switch off cleaning machine and restart: Contact Service if the fault persists.</li> </ul>
<p>269</p>  <p>Abortion Critical fault! Slow venting not possible.</p>	<p>Vacuum in the cleaning chamber is not released during the safety test.</p>	<p>Check the following possibilities:</p> <ul style="list-style-type: none"> <li>• Air intake and exhaust openings in the cleaning chamber (<i>Fig. 3.12.1.A</i>) clogged?</li> <li>• Switch off cleaning machine and restart: Contact Service if the fault persists.</li> </ul>
<p>270</p>  <p>Abortion Critical fault! Fast venting not possible.</p>	<p>Vacuum in the cleaning chamber is not released during the safety test.</p>	<p>Check the following possibilities:</p> <ul style="list-style-type: none"> <li>• Air intake and exhaust openings in the cleaning chamber (<i>Fig. 3.12.1.A</i>) clogged?</li> <li>• Switch off cleaning machine and restart: Contact Service if the fault persists.</li> </ul>

<p>271</p>  <p>Abortion          Critical fault!          Basket rotation drive defective.</p>	<p>Basket rotation drive communication error and speed fault during the safety test.</p>	<p>Check the following possibilities:</p> <ul style="list-style-type: none"> <li>• Check correct seating of the cleaning basket</li> <li>• Switch off cleaning machine and restart: Contact Service if the fault persists.</li> </ul>
<p>272</p>  <p>Abortion          Critical fault!          Ultrasound generator defective.</p>	<p>Ultrasound generator communication error during the safety test.</p>	<p>Check the following possibilities:</p> <ul style="list-style-type: none"> <li>• Switch off cleaning machine and restart: Contact Service if the fault persists.</li> </ul>
<p>273</p>  <p>Abortion          Critical fault!          Fan defective.</p>	<p>A fan is blocked or defective during the safety test.</p>	<p>Check the following possibilities:</p> <ul style="list-style-type: none"> <li>• Check fans for foreign bodies and remove if necessary</li> <li>• Switch off cleaning machine and restart: Contact Service if the fault persists.</li> </ul>
<p>274</p>  <p>Abortion          Critical fault!          Both fans defective.</p>	<p>Both fans are blocked or defective during the safety test.</p>	<p>Check the following possibilities:</p> <ul style="list-style-type: none"> <li>• Check fans for foreign bodies and remove if necessary</li> <li>• Switch off cleaning machine and restart: Contact Service if the fault persists.</li> </ul>
<p>278</p>  <p>Abortion          Critical fault!          Memory chip defective.</p>	<p>Software / electronics error.</p>	<p>Check the following possibilities:</p> <ul style="list-style-type: none"> <li>• Switch off cleaning machine and restart: Contact Service if the fault persists.</li> </ul>
<p>291</p>  <p>Abortion          Critical fault!          Basket drive defective or blocked.</p>	<p>Basket rotation drive defective or blocked.</p>	<p>Check the following possibilities:</p> <ul style="list-style-type: none"> <li>• Check motor shaft of the basket rotation drive for ease of movement.</li> <li>• Switch off cleaning machine and restart: Contact Service if the fault persists.</li> </ul>
<p>292</p>  <p>Warning          Critical fault!          Ultrasound generator defective.</p>	<p>No communication with ultrasound generator.</p>	<p>Check the following possibilities:</p> <ul style="list-style-type: none"> <li>• Switch off cleaning machine and restart: Contact Service if the fault persists.</li> </ul>

<p>297</p>  <p>Warning! After pressing the button with the warning symbol:</p> <p>heater was switched off during the drying as liquid was detected.</p>	<p>If liquid is detected at the lower fill level sensor (or this sensor is defective) during the drying, the heater is switched off and the warning message is displayed.</p>	<p>Check the following possibilities:</p> <ul style="list-style-type: none"> <li>• Filling level sensor <i>Empty level</i> (installed under the sieve insert) (Fig.9.1.4.1.F) soiled? Clean with suitable cloth if necessary.</li> <li>• Fill level sensor <i>Empty level</i> (Fig.9.1.4.1.F) damaged (scratches, cracks)?</li> <li>• Retrofit ant-reflection sleeve for <i>Empty level</i> fill level sensor.</li> <li>• Switch off cleaning machine and restart: Contact Service if the fault persists.</li> </ul>
<p>299</p>  <p>Warning! Contact the service. Change of the rotation seal is necessary! See operating instructions.</p>		<p>Check the following possibilities:</p> <ul style="list-style-type: none"> <li>• Take machine out of operation immediately.</li> <li>• Contact Service</li> </ul> <p>Safe operation of the cleaning machine is no longer guaranteed. The required service must strictly be performed to continue operating the cleaning machine. The manufacturer shall not accept any liability for injuries to persons and property damage resulting from further operation.</p>

**Fault information:** This screen (*Fig. 11.1.2*) is always displayed if the cleaning program has not been ended properly: e.g. after any fault in the cleaning machine or a power failure during cleaning.  
**Checking**



Fig. 11.1.2 Fault information for cleaning machine checking

## 11.2 Cleaning machine faults without indication on the display

Fault	Fault clearance
Cleaning machine cannot be started or stops.	Check the following possibilities: <ul style="list-style-type: none"> <li>• Disconnect cleaning machine from the mains power supply. Then check fuse(s) for mains cable; replace if necessary</li> <li>• Switch off cleaning machine and restart: Contact Service if the fault persists</li> </ul>
Liquid discharge from bottom case opening.	Check the following possibilities: <ul style="list-style-type: none"> <li>• Check media tank filling level</li> <li>• Cleaning deflagration protection (see <i>Chapter 11.3.1</i>)</li> <li>• Contact Service if the fault persists</li> </ul>

## 11.3 Fault clearance by user



**DANGER**

Risk of electric shock from live parts in the interior of the cleaning machine!

Always unplug the mains plug before opening the cleaning machine.

The manufacturer shall accept no liability for damage caused by unauthorised interventions on the cleaning machine.



**CAUTION**

Risk of injury from sharp edges in the cleaning machine and from moving / rotating components (e.g. toothed belts).



**CAUTION**

Risk of injury from hot surfaces!

The vacuum pump, solenoid valves, drives and heater can still be hot immediately after operation of the cleaning machine.

## 11.3.1

### Cleaning deflagration protection



If liquid discharges at the bottom connection for venting the media tanks (*Fig. 11.3.1.1.G*), the deflagration protection should be cleaned afterwards.

#### Procedure

1. Remove the two 3 mm Allen screws (*Fig. 11.3.1.1.A*) on the bottom of the cleaning machine.
2. Remove the four 3 mm Allen screws (*Fig. 11.3.1.2.B*) on the rear side of the cleaning machine and remove the cover (*Fig. 11.3.1.2.C*) of the service opening.
3. Detach the two tube connections (*Fig. 11.3.1.2.E*) by pulling on the respective tube and simultaneously pressing on the grey ring (*Fig. 11.3.1.3.F*).
4. Remove the deflagration protection (*Fig. 11.3.1.3.D*) and drain the residual liquid present.
5. Let the deflagration protection dry (leave for approx. 30 minutes in the removed condition or blow out with compressed air).
6. Reinstall the deflagration protection in the cleaning machine in reverse order (*Fig. 11.3.1.1.A*).

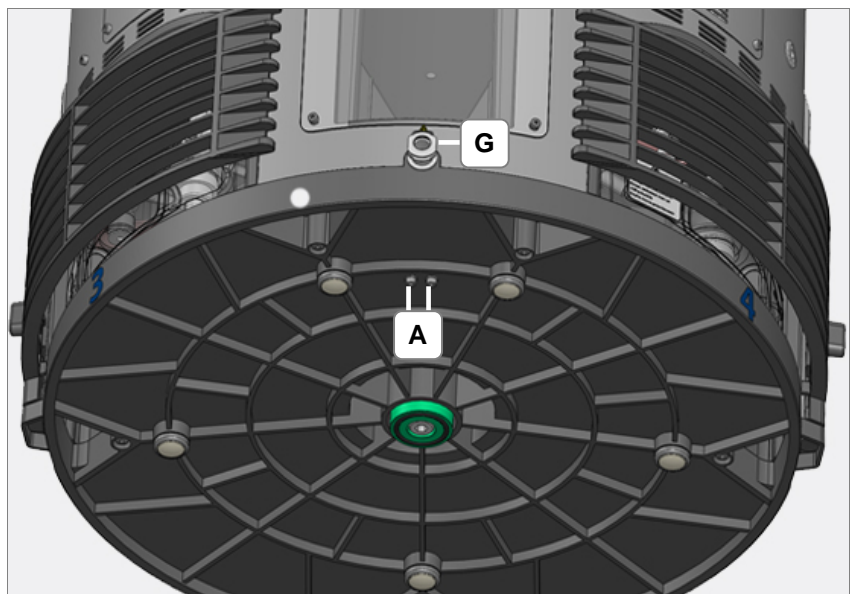

Fig. 11.3.1.1 Bottom view of cleaning machine with screw connection

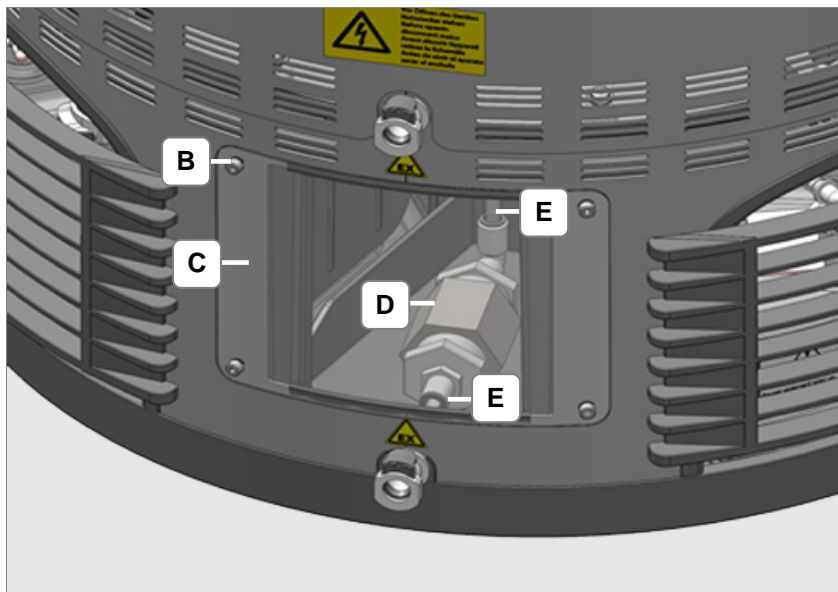

Fig. 11.3.1.2 Service opening with deflagration protection

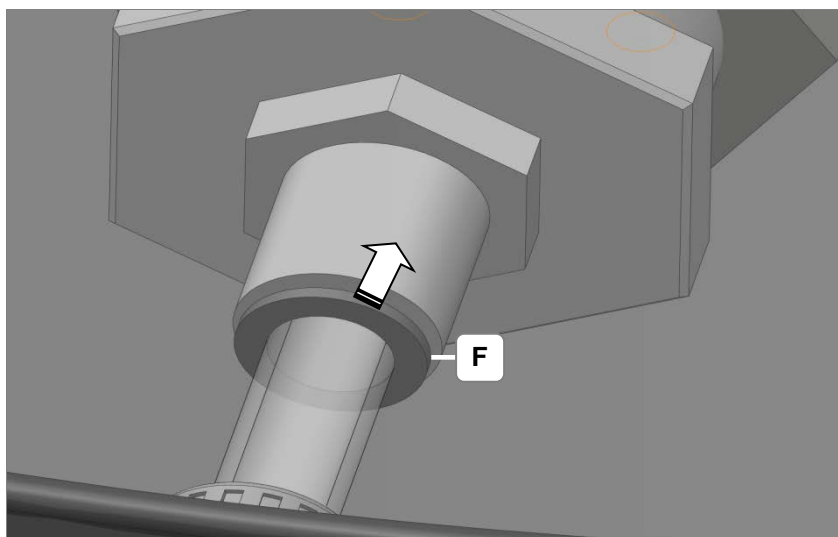

Fig. 11.3.1.3 Tube connection with locking ring

  
**ATTENTION**

In the event of further discharge of liquid (> droplets), the cleaning machine must not be further operated. Contact your dealer or the manufacturer.

## 11.3.2

### Manual venting of the cleaning chamber



If the medium is not conducted from the cleaning chamber back into the media tank, there can be a fault for the automatic venting.

The following error message is shown on the display: *Cleaning chamber does not drain.*

The cleaning chamber can be vented manually using the bleed screw in the cover of the cleaning chamber.

#### Procedure

Open the bleed screw using a 5 mm Allen key. There is a feedthrough for the Allen key in the handle of the cover of the cleaning chamber.

By removal of the vacuum in the cleaning chamber, the medium should flow back into the relevant media tank.

If this is not the case, contact the Service Centre.

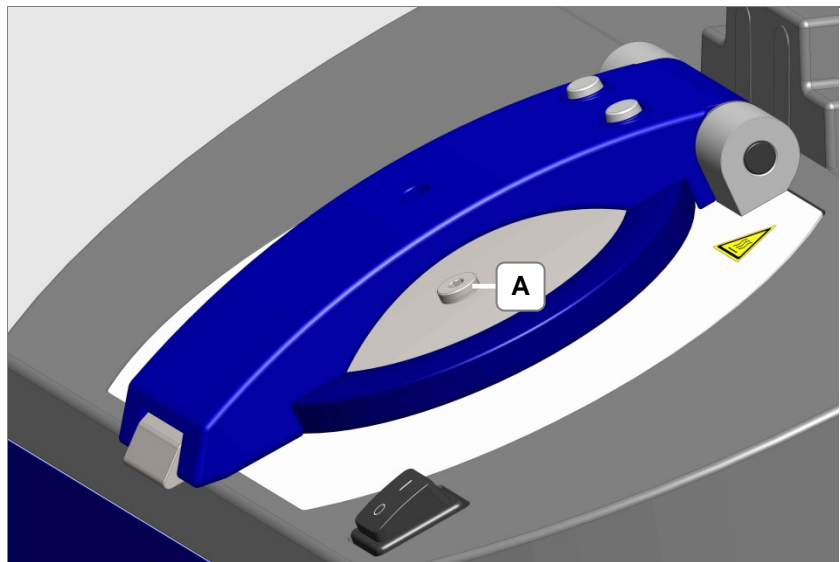

Fig. 11.3.2.1 Position of the bleed screw

## 11.4

### Repairs

---



For safety reasons, repairs must only be performed by trained staff which has been authorised by the manufacturer.

The manufacturer shall accept no liability for damage caused by unauthorised and incorrect interventions on the cleaning machine.

---

**Opening must only be performed by authorised qualified electricians**

Risk of electric shock from live parts in the interior of the cleaning machine!

Always unplug the mains plug before opening the cleaning machine.

The manufacturer shall accept no liability for damage caused by unauthorised interventions on the cleaning machine.

---



Risk of injury from sharp edges in the cleaning machine and from moving / rotating components (e.g. toothed belts).

---



Risk of injury from hot surfaces!

The vacuum pump, solenoid valves, drives and heater can still be very hot immediately after operation of the cleaning machine.

---

Contact the supplier or manufacturer in the case of cleaning machine faults which cannot be rectified using the instructions for fault clearance in this operating manual.

If any return to a service centre is required:

- use the original packaging to prevent transport damage.
- enclose as specific as possible description of the fault.

## 11.5

### Shipment of the machine

If any shipment of the machine is required:



- Risk of explosion during transport! Strictly empty the media container before shipment and also ensure that the cleaning chamber is emptied!
- Only use the original packaging to prevent transport damage.
- Enclose an as specific as possible description with the return (error description, maintenance instructions etc.)

## 12

### Decommissioning and disposal



The cleaning machine components can be supplied to electronics and metal recycling for disposal. The manufacturer also accepts old components for disposal.

Dispose of used cleaning and rinsing media in accordance with the applicable national regulations.

## 13

### Manufacturer address / contact address

#### Elma Schmidbauer GmbH

Gottlieb-Daimler-Str. 17, D-78224 Singen

Phone (head office) +49 (0) 7731 / 882-0

Fax (head office) +49 (0) 7731 / 882-266

[info@elma-ultrasonic.com](mailto:info@elma-ultrasonic.com)

[www.elma-ultrasonic.com](http://www.elma-ultrasonic.com)

## 14 Appendix 1: Activated carbon unit

### 14.1 Description

The activated carbon unit consists of the base frame, the retaining bracket and 1 condensate separator and 2 activated carbon cartridges.

The base frame can be either floor-standing or wall-mounted. The condensed solvent vapours are collected in the condensate separator and must be drained regularly by the user. Suitable activated carbon granulate must be filled in the two activated carbon cartridges and changed regularly by the user.

#### Scope of delivery

Activated carbon unit, 2 fillings of activated carbon granulate, each of 500 g, funnel for filling the activated carbon cartridges, 1 set of PE filter inserts, labels for noting the maintenance, PTFE sealing tape, fastening material for optional wall mounting of the activated carbon unit.

---



Fire and explosion hazard!

Solvents are separated at the activated carbon unit. The instructions from *Chapter 8* of this operating manual are applicable.

Observe the applicable safety regulations for handling solvents.

Keep all kinds of ignition sources away.

Prevent ignition sparks from electrostatic discharge. Discharge possible electrostatic charges (body charge) by touching any grounded equipment before handling flammable media: e.g. water tap, metal surface of the case of the cleaning machine or use ESD protective equipment (ESD arm band).

The connected cleaning machine must not be operated during commissioning and maintenance of the activated carbon unit.

---

#### Disposal of used operating materials



Used operating materials must be disposed of in accordance with the regulations. No disposal via the sewer system! Dispose of used operating materials in accordance with the national disposal regulations for the media (see safety data sheet).

Used activated carbon granulate is also taken back by the supplier or its manufacturer.

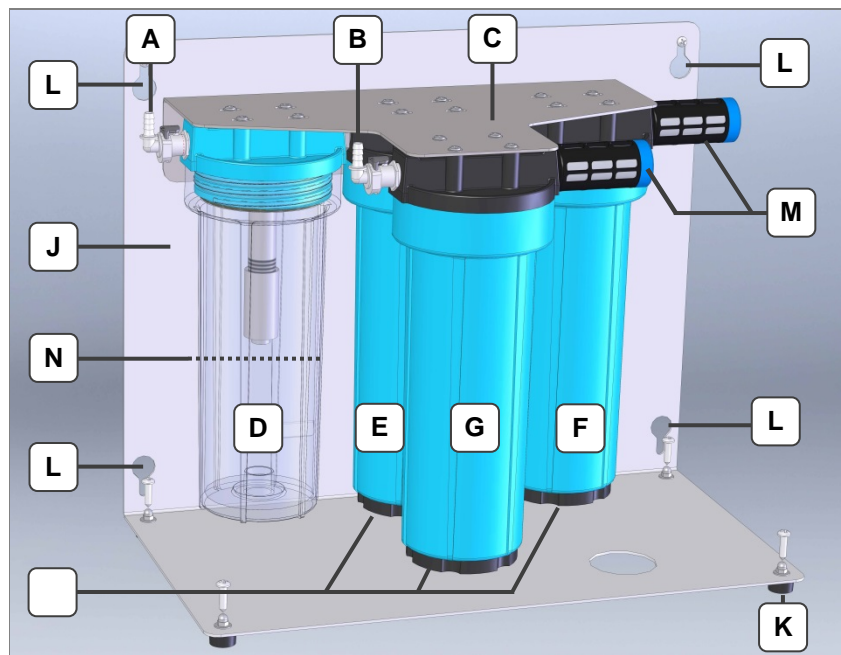

Fig. 14.1.1 Upright activated carbon unit

- A Quick coupling** for connection of the exhaust air tube for venting the cleaning chamber. In order to prevent mix-ups for the connections, this coupling has a red marking ring at the activated carbon unit and also the associated connection at the cleaning machine.
- B Quick coupling** for connection of the exhaust air tube for venting the cleaning chamber.
- C Retaining plate** attached in the base frame (**J**), detachable for emptying the condensate separator / activated carbon cartridges.
- D Condensate separator**, can be unscrewed with filter insert.
- E Activated carbon cartridge, 1st stage**
- F Activated carbon cartridge, 2st stage**
- G Activated carbon cartridge, 1nd stage**
- H Screw plug**, can be unscrewed for filling / emptying the activated carbons.
- J Base plate** enables floor-standing operation on the rubber feet (**K**) or for wall mounting (floor bracket and feet upwards) using the cut-outs (**L**).
- M PE filter** can be unscrewed for maintenance interval.
- N Maximum filling level of separated condensate** (must be below the filter in the condensate separator).

## 14.2 Filling / Installation / Commissioning

### Filling the activated carbon cartridges

The activated carbon cartridges are not filled when delivered. Proceed as follows for the filling:

Detach the retaining plate (C) from the base plate (J).

Open the screw plugs (H) of the filter cartridges and fill these using the funnel: 1 packet each of the supplied activated carbon granulate per filter cartridge.

Close the screw plugs and reattach the retaining plate.

### Installation

The base plate can either be placed on the plastic feet or wall-mounted.

Benefit for wall mounting: the condensate separator can be unscrewed for emptying without having to detach the retaining plate (Fig. 14.2.1.C) from the base plate.

For wall mounting, first fasten the base plate (floor bracket / feet upwards) using the supplied mounting material. Attach the retaining plate to the base plate (see Fig. 14.2.1).

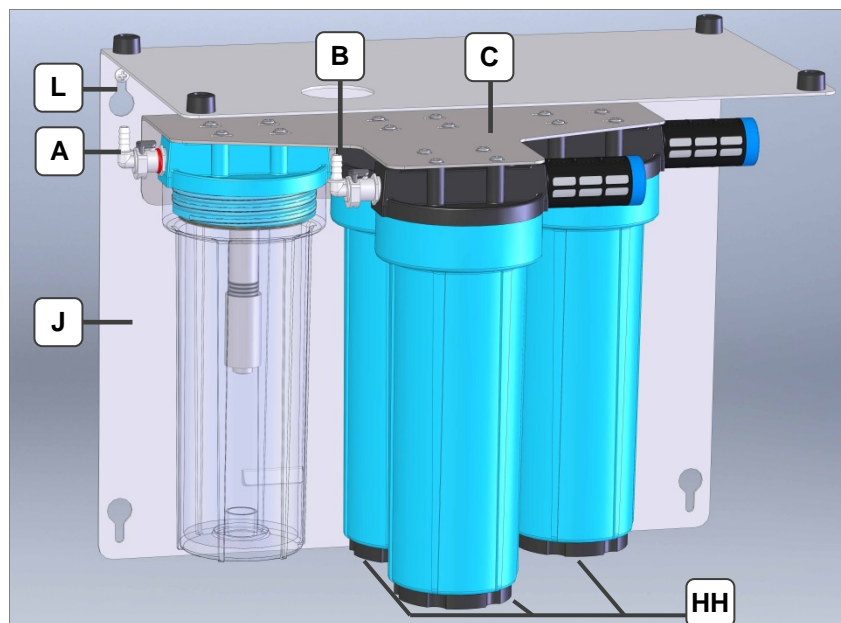

Fig. 14.2.1 Activated carbon filter in wall mounting position

### Connecting exhaust air tubes

1. Cut the exhaust air tubes included in the scope of delivery to length and put these on the quick couplings (A and B).
2. Insert the quick couplings (A and B) into the corresponding mating pieces of the activated carbon unit so that these are securely engaged.

  
**ATTENTION**

Strictly observe the correct assignment of the two exhaust air tubes at the connections of the cleaning machine:

Connect connection **A** (red ring) of the activated carbon unit to connection **A** (red ring) of the cleaning machine (Fig. 14.2.2.A).

Connect connection **B** of the activated carbon unit to connection **B** of the cleaning machine (Fig. 14.2.2.B).

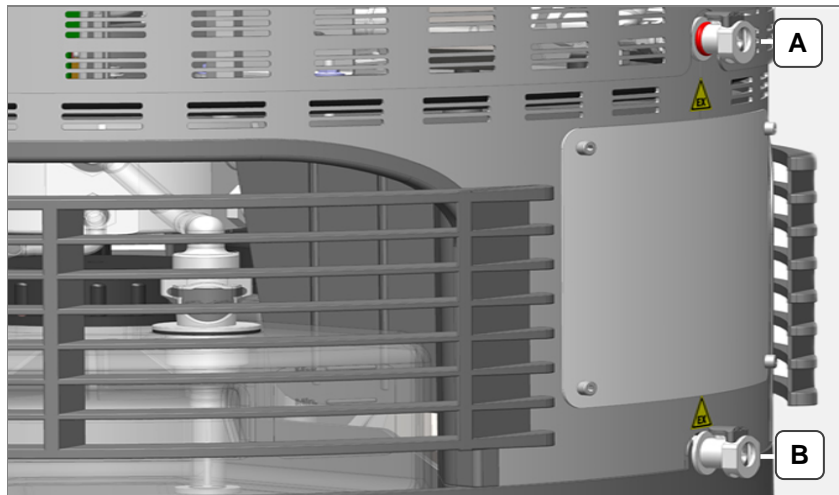

Fig. 14.2.2 Connections for venting

**Marking label**

Mark an adhesive label (included in the scope of delivery) with date and cleaning cycle (see Settings, Operating Hours) and attach it to the retaining bracket or base plate of the activated carbon unit.

## 14.3



DANGER

## Maintenance

---

Fire and explosion hazard!

Solvents are separated at the activated carbon unit. The instructions from *Chapter 8* of this operating manual are applicable.

Observe the applicable safety regulations for handling solvents.

---

### 14.3.1

#### Emptying condensate separator

**Interval** After view, at the latest if the filling level of the separated solvent has risen to approx. 20 mm below the filter in the condensate separator (*Fig. 14.1.1.N*).

**Procedure** Remove the retaining plate (C) with the condensate separator (D) and the activated carbon cartridges (E / F / G). In the case of wall mounting, the condensate separator can be unscrewed while the retaining bracket is attached.

Unscrew the condensate separator out of the holder. Ensure that you do not spill any solvent in doing so.

After emptying, screw the condensate separator back into the holder.

### 14.3.2

#### Replacing activated carbon granulate

**Interval** The activated carbon granulate must be emptied depending on the operating conditions. It is recommended to change the activated carbons depending on the odour development. However, the activated carbons should be changed at the latest after 3 months or 150 cleaning cycles (information applies for unfavourable operating conditions: e.g. high ambient and media temperature, high proportion of drying cycles).

#### Activated carbon granulate specification

Technical requirements for activated carbons:

- Activated carbons for organic solvents
- Butane activity: 32 % (the replacement interval must be adjusted depending on the butane activity; 32 % - 150 cycles, 20 % - 100 cycles, ...)
- Grain size:  $\geq 2$  mm
- Free of dust

Activated carbon granulate recommended by the manufacturer:

Type: EcoSorb BX-Plus 2 mm

Manufacturer: Jacobi

Germany Sales: Overlack GmbH

- Procedure** Unclip the quick couplings (A / B) of the exhaust air tubes from the connections on the activated carbon unit.
- Detach the retaining plate (C) from the base plate (J).
- Open the screw plugs (*Fig. 14.1.1.H*) of the activated carbon cartridges one after the other.
- Empty the used activated carbon granulate.
- Place the retaining bracket with the condensate separator and the activated carbon cartridges turned over on a work surface.
- Fill the required quantity of new activated carbon granulate using the funnel.
- Close the screw plug.
- Reattach the retaining plate to the base plate.
- Mark a new label and attach it so that it is visible to the activated carbon unit.

### 14.3.3 Changing PE filter

There is a total of 6 PE filters in the activated carbon unit. The filters are available as a set and all four must be changed.

- Order number** Elma order number 105 3821
- Interval** Annually or depending on the operating conditions: If the required cleaning time gradually becomes longer and/or if an appropriate warning message is shown on the display.
- Changing outer PE filter** Unscrew the outer PE filter (*Fig. 14.3.3.1.M*) from the activated carbon cartridge.
- Wrap Teflon sealing tape around the thread of the new PE filter.
- Screw in the new PE filter hand tight.
- Replacing PE filter in the condensate separator** Unscrew the condensate separator (see also *Chapter 14.3.1 Emptying condensate separator*) from the holder.
- Unscrew the used PE filter (*Fig. 14.3.3.1.O*) from the mounting thread.
- Wrap Teflon sealing tape around the thread of the new PE filter.
- Screw in the new PE filter hand tight.
- Screw the condensate separator back into the holder tightly.
- Replacing PE filters in activated carbon cartridges** It is recommended to carry out the replacement of the PE filters in the activated carbon cartridges in the course of replacing the activated carbon granulate.
- Detach the retaining plate (C) from the base plate (J).
- Unscrew the activated carbon cartridge (see also *Chapter 14.3.2 Replacing activated carbon granulate*) from the holder.
- Empty the used activated carbon granulate.

Unscrew the used PE filter (*Fig. 14.3.3.1.P*) from the mounting thread.

Wrap Teflon sealing tape around the thread of the new PE filter.

Screw in the new PE filter hand tight.

Screw the activated carbon cartridge back into the holder tightly.

Open the screw plug (*Fig. 14.3.3.1.H*) of the activated carbon cartridge and fill the required quantity of new activated carbon granulate using the funnel.

Close the screw plug tightly.

Reattach the retaining plate to the base plate.

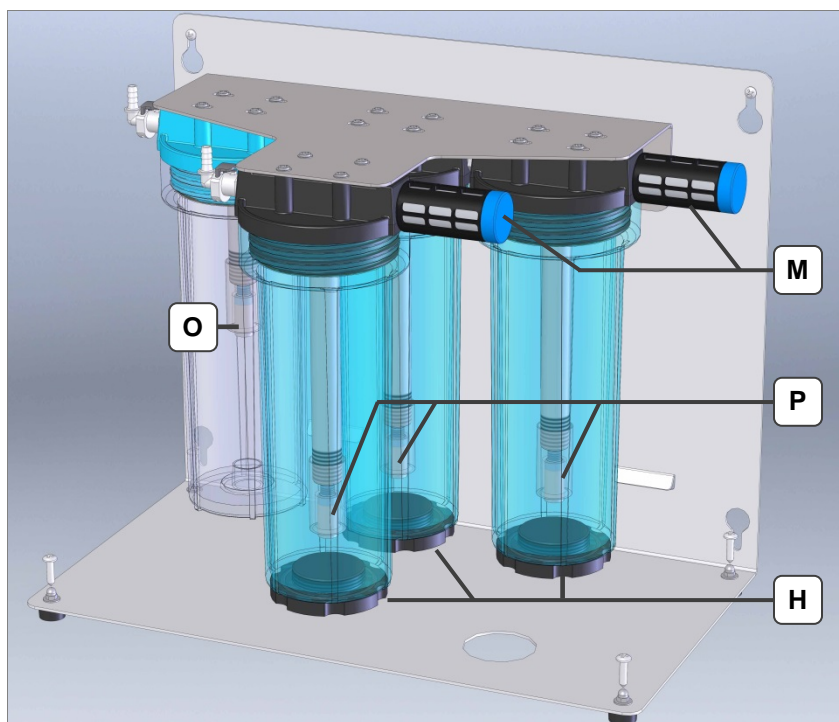

Fig. 14.3.3.1 Sectional view of activated carbon filter

## 15

### Appendix 2: Pager

The pager is a hand-held device for mobile remaining time display of the cleaning program.

As soon as a cleaning program has been started (see *Chapter 6.3 and Fig. 6.3.4*), the remaining running time of the cleaning program can be transmitted from the cleaning machine to the pager.

The distance from the cleaning machine is not relevant for displaying the remaining running time afterwards.



Fig. 15.1 Pager front / rear view

#### Activating pager

1. First start the cleaning program.
2. Make the pager ready by shaking it for a short time: As soon as the green LEDs flash alternately (running light), the pager is ready for data reception for 30 seconds.
3. Hold the pager with the rear side facing the display. The sensor on the rear side of the pager (*Fig. 15.1.A*) must then be located in the range of the display.
4. Press the operating button #2 (see *Fig. 15.2.#2*). The data transmission is performed.

As soon as the LED for cleaning time on the pager lights, the data transmission is completed and the pager is activated.

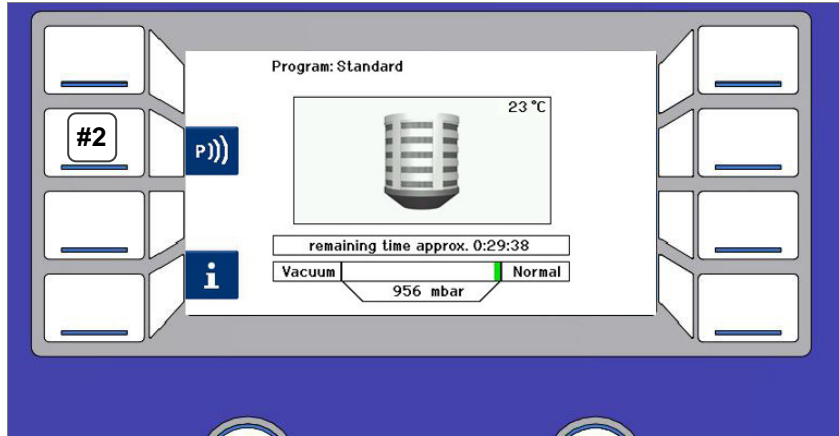

Fig. 15.2 Operating button #2

**Pager remaining time display**

The "> 15 min" LED flashes when the remaining time is less than 15 minutes.

The "~ 10 min" LED lights when the remaining time is approx. 10 minutes.

The "~ 10 min" LED flashes when the remaining time is less than 10 minutes.

The "~ 5 min" LED lights when the remaining time is approx. 5 minutes.

The "~ 5 min" LED flashes when the remaining time is less than 5 minutes.

When the cleaning process has completed, the LED *finished* lights and a vibration alarm is produced at the same time and an alarm tone afterwards. The LED is extinguished 30 seconds after the last alarm tone.

**Change battery indicator**

If the *low battery* LED lights, the batteries must be replaced.

Battery type: 2x AAA.

Rechargeable batteries with the appropriate capacity can also be used instead of batteries.

**Disposal of used batteries**



Used batteries must be disposed of in accordance with the regulations. Dispose of batteries in accordance with the national disposal regulations.

## Appendix 3: Procedure and parameter recommendations using Expert Mode

**Expert Mode** Beyond the possibilities explained in *chapter 7.2* of the operating manual for the creation of own cleaning programs with changed parameters in the *Standard Mode*, using the *Expert Mode* your own cleaning programs with

- up to 5 sequences in each case in the cleaning step and in the rinsing steps *Rinse1* - *Rinse3* and
- up to 2 sequences in the drying step and
- sequence-specific parameter variations

can also be freely programmed.

**Activating / deactivating Expert Mode** You reach the *Expert Mode* from the *Standard Mode* by clicking in the *Create / change programs* display screen on the crossed-out folder shown on the bottom left as navigation symbol (*chapter 7.2.1*, *Fig. 7.2.1.1*).

The display screen changes after clicking from *Standard Mode* to *Expert Mode* and the folder is no longer shown as crossed out.

The display screens are then shown in *Expert Mode* until the *Standard Mode* is restored in the *Create / change programs* screen by clicking on the folder icon again.

Programs created and saved in the *Expert Mode* are also retained after return to the *Standard Mode* and can be selected from the list of created/to be changed programs.

It is recommended to accompany the following explanations and make the changes on the device using the practice programs (by creating a new program from a program copy with changed name) when *Expert Mode* is activated.

**Expert Mode for the cleaning step** In the *Expert Mode*, the cleaning step can be subdivided into up to 5 different consecutive sequences *Clean1*, *Clean2*, ..., *Clean5* in the process with freely programmable duration in each case.

Among these

- the sequences *Clean1*, ..., *Clean4* with various parameters in each case for the ultrasound and the oscillation or rotation movements of the cleaning basket and
- the sequence *Clean5* with various parameters from *Clean1*-*Clean4* of the spinning or oscillation or rotation movements of the cleaning basket

can be freely programmed in the *Expert Mode*.

The parameters

- "pulse" or "normal" of the ultrasound mode, for finely matched oscillation or

- rotation and the rotation direction change during spinning for each of the 5 cleaning sequences are only freely programmable in the *Expert Mode*.

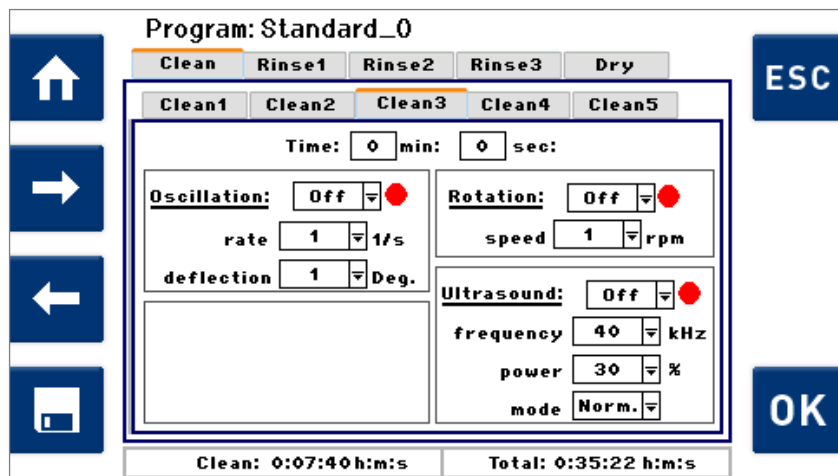

Fig.16.1 Screenshot of the options for *Clean3* (analogous display for *Clean1*, *Clean2* and *Clean4*).

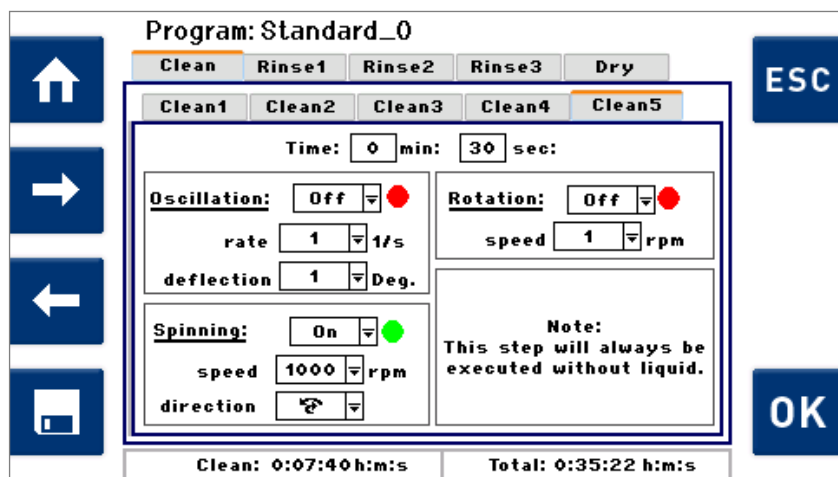

Fig.16.2 Screenshot of the options for *Clean5*.

### Expert Mode for the 3 rinsing steps

Each of the 3 rinse steps *Rinse1* – *Rinse3* can also be programmed in 5 consecutive sequences in the process with selected duration in each case. For example, *Rinse1* can be subdivided into the sequences *Rinse1.1*, *Rinse1.2*, ..., *Rinse1.5* (accordingly also *Rinse2* and *Rinse3*).

Among these

- the sequences *Rinsex.1*, ..., *Rinsex.4* with different parameters in each case for the ultrasound, the oscillation or rotation movements of the cleaning basket and
- the sequence *Rinsex.5* with parameters of the spinning or oscillation or rotation movements of the cleaning basket can be freely programmed in the Expert Mode.

The parameters

- "pulse" or "normal" of the ultrasound mode,

- of a finely matched oscillation or rotation for each of the rinse sequences x.1 - x.4 in the rinse steps *Rinse1* – *Rinse3* and the parameters
- of the rotation direction change for spinning for each of the rinse sequences x.5 in the rinse steps *Rinse1* – *Rinse3* are only freely programmable in the Expert Mode.

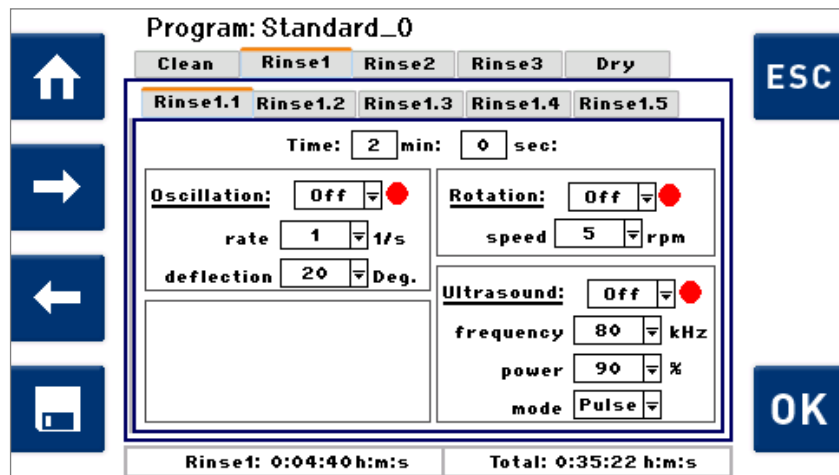

Fig.16.3 Screenshot of the options for *Rinse1.1* (analogous display for *Rinsex.2*, *Rinsex.3*, *Rinsex.4* with x=1, 2, 3).

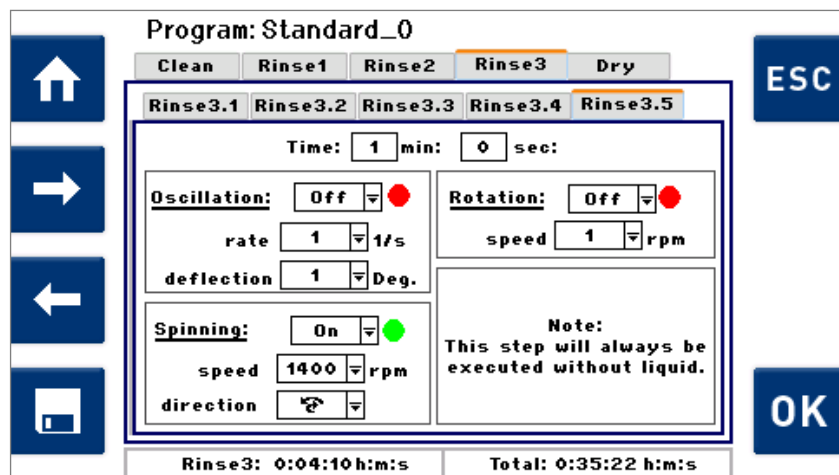

Fig.16.4 Screenshot of the options for *Rinse3.5* (analogous display for *Rinsex.5*, x=1, 2, 3).

### Expert Mode for the drying step

In the *Expert Mode*, the drying step can also be freely programmed with selected duration in each case as 2 consecutive, different sequences *Dry1*, *Dry2*. Thereby

- the sequence *Dry1* with parameters for spinning, oscillation or rotation movements of the cleaning basket and
- the sequence *Dry2* with parameters for the number, pressure and duration of the vacuum steps below this pressure and for oscillation or rotation movements of the cleaning basket in these steps

can be programmed in the *Expert Mode*.

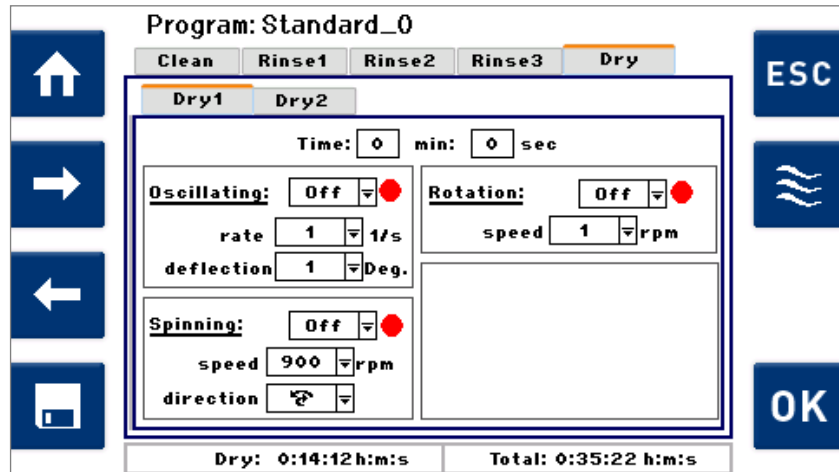

Fig.16.5 Screenshot of the options for *Dry1*.

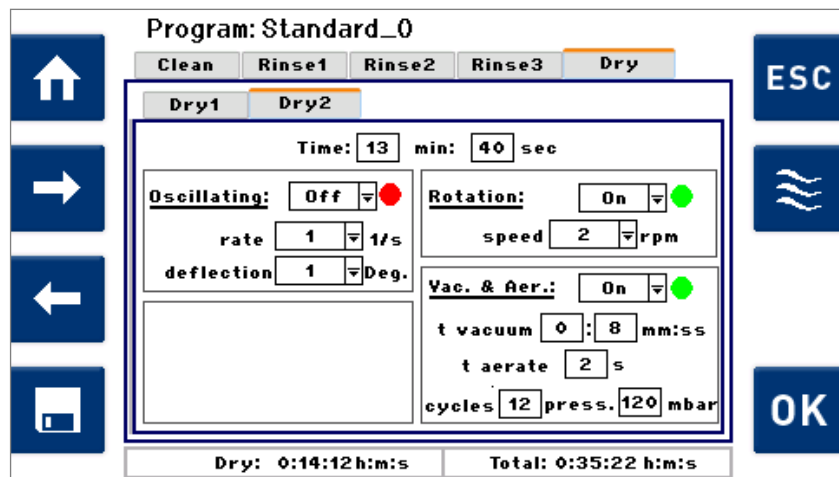

Fig.16.6 Screenshot of the options for *Dry2*.

### Skipping of sequences and steps

A cleaning, rinsing or drying sequence is not executed if its duration is specified as 0 min 0 sec irrespective of other parameters of this sequence. *Fig. 16.1* shows such an example for the sequence *Clean3*.

If the *sequences 1-4* for any of the steps *Clean*, *Rinse1*, *Rinse2* or *Rinse3* are all specified with the duration 0 min 0 sec, the *Sequence 5* of this step is also not executed and the complete step is skipped. In this case, the intended medium for this step is also not suctioned and therefore also not discharged.

In the event of process problems with the stored standard cleaning programs in the *Clean*, *Rinse1 – Rinse3* or *Dry* steps, it is recommended to use the *Expert Mode*.

In the following 3 chapters, process recommendations based on problem examples are given and the creation of special cleaning programs in the *Expert Mode* is explained.

## 16.1 Cleaning parameters recommendations in Expert Mode

Two example problem solutions using modifications of the standard cleaning programs are presented that provide possibilities of the Expert Mode:

**Example 1** The parts have residues adhering very firmly to the parts surfaces such as (e.g. caused by corrosion) oxide deposits or resinified oil or grease residues.

It is initially advisable in Expert Mode to activate the "pulse" ultrasound mode for the ultrasonic cleaning (with slower rotation of the cleaning basket left unchanged).

With this the "normally" used "double half-wave modulation" of the ultrasound amplitude with the doubled mains frequency is also overlaid with a modulation that generates high sound pressure peaks for a short time in the milliseconds range and ensures sustained exceedance of the cavitation threshold.

The average sound pressure amplitude and thus the heating rate of the medium treated with ultrasound in the work chamber therefore do not increase in the "pulse" mode.

**Example 2** The parts have both

- residues adhering very firmly to the parts surfaces such as oxide layers caused by corrosion or resinified oil or grease residues

as well as

- residues in fine holes, blind holes and gaps with internal diameter in the less than 1/10 mm range

Then it is advisable to clean one after the other with both available ultrasound frequencies 40 and 80 kHz in the "pulse" ultrasound mode in two sequences *Clean1* and, e.g. *Clean2* with slow rotation of approx. 3 rpm.

The prerequisite for effective ultrasonic cleaning in the holes, blind holes and gaps is that the parts positioning in the rotating cleaning basket enables

- the displacement of the otherwise, also in vacuum, still remaining residual air bubble there due to the penetrating cleaning medium and
- the spinning out or draining again of the cleaning medium

In the following *Clean3* sequence, the soiling cleaned off using ultrasound from the fine holes, blind holes and gaps can be removed due to its short-term (< 30 seconds) flow triggered by a fast ( 2-3 Hz) oscillation movement with sufficient deflection (dependent on the positioning around 3-5°).

Prerequisite of the flow using fast oscillation is in turn appropriate parts positioning far enough on the outside in the rotating cleaning basket for the holes and gaps to be flowed through.

Depending on the result, it can be advisable after removal of the soiling in *Clean3* to perform ultrasonic cleaning again using 40 or 80 kHz in *Clean4*.

With the procedure described above, the intended ultrasonic cleaning duration in the standard cleaning program is divided onto the above 2 or 3 ultrasound sequences and additional cleaning time is only programmed for the additional fast oscillation.

## 16.2

### **Rinsing parameters recommendations in Expert Mode**

One example problem solution using modifications of the standard cleaning program shows which possibilities of the Expert Mode are enabled for the probably most frequent rinsing problem:

The parts still have residues of the cleaning medium in fine holes, blind holes and gaps in the range of internal diameters of less than 1/10 mm that in the case of unfavourable positions also reach the outside surfaces from there and become visible there as stains or blemishes.

On the one hand, it is then advisable firstly to rinse with ultrasound support (80 kHz) with slow rotation in the rinsing steps *Rinse1 – Rinse3*.

The prerequisite for effective ultrasound-supported rinsing also in the holes, blind holes and gaps is that the parts positioning in the rotating cleaning basket enables

- the displacement of the, also in vacuum, still remaining residual air bubble there due to the penetrating rinsing medium and
- the spinning out or draining again of the rinsing medium

On the other hand, it is advisable for the ultrasound-supported rinsing performed in the sequences *Rinsex.1* and *Rinse.3* to be followed in the sequences *Rinsex.2* and *Rinsex.4* in each case for a short time (< 30 seconds) by flow through the holes and gaps produced by fast (2-3 Hz) oscillation movement with sufficient deflection (dependent on the positioning 3-5°).

Cleaning medium is rinsed away from poorly accessible parts surfaces and also removed from the holes and gaps.

The positioning far enough on the outside in the rotating cleaning basket of the holes and gaps to be flowed through must be observed as prerequisite for the effectiveness of the fast oscillation.

Thereby it is advisable to initially divide the intended overall ultrasound-supported rinsing duration in the standard cleaning program between the above 2 ultrasonic rinsing sequences and only spend additional rinse time for the additional fast oscillation in between.

## 16.3 **Drying parameters recommendations in Expert Mode**

### 16.3.1 **Spinning**

If permitted by the parts and the parts carrier used (rotating basket), the drying can be made much easier by spinning of the remaining rinsing medium in the last rinse step *Rinsex* (usually *Rinse5*).

The then still to be evaporated (using vacuum and cleaning chamber wall heater) amount of the last rinsing medium on the parts and rotating basket surfaces is then determined by the duration and effectiveness of the preceding spinning sequences in *Rinsex.5* (Fig. 16.4) and *Dry1* (Fig. 16.5).

Thereby, after the draining of the medium, there is another program-independent pre-spinning of 20 seconds duration at max. 500 rpm without vacuum before every programmed spinning sequence with duration > 0 so that a larger part of the spun-off medium can discharge out of the cleaning chamber into the medium tank when the drain valve is still open. It is not until afterwards that the programmed spin sequence with closed drain valve under vacuum <=120 mbar starts with the programmed parameters for duration and (for logical reasons higher than 500 rpm) speed.

In turn, the parts positioning in the rotating basket influences the effectiveness of the spinning: The closer the parts surfaces are arranged to the rotation axis of the rotating basket, the lower is the effective centrifugal force for spinning off the rinsing medium.

It follows from this for the use of the spinning that

1. the parts must be positioned as far to the outside as possible in the rotating basket, favourably for the process and balanced around the rotation axis,
2. an as high as possible rotation speed (up to 1400 rpm) and a spinning duration with direction change where liquid is still spun off (usually a total of 40 = 2x 20 seconds) must be programmed in Dry1 (*Fig. 16.4*).

The practical spinning duration in individual cases can be determined using tests with abort after the spinning and determination of the residual moisture by simply weighing the parts basket with parts after the spinning.

## 16.3.2 Vacuum drying

Both parts and basket surfaces as well as the interior surfaces of the cleaning chamber are evenly dried in the Elmasolvex VA by

- evaporation of the last rinsing medium from the mentioned surfaces with running removal of the evaporated rinsing medium via the vacuum outlet of the cleaning chamber
- and
- subsequent delivery by heat radiation of the evaporation heat removed from the mentioned surfaces by rinsing medium evaporation, output from the heated wall at 2 places on the outside of the cleaning chamber

It results from the uniform vapour pressure of the rinsing medium in the entire cleaning chamber that the coldest surface dries the worst, i.e. has the highest residual moisture at the end of the drying process.

For the maximum achievable temperatures of approx. 65 °C on the interior wall using the outside heater of the cleaning chamber the outgoing heat radiation is infra-red radiation with maximum wave length of 7-10 µm.

With rotating basket, this infra-red radiation only directly reaches the parts surfaces where there is a direct visual contact through the rotating basket to the cleaning chamber wall.

The rotating basket must resemble an ideal black body as much as possible, i.e. a dark (black) and non-reflecting surface, so that it receives (absorbs) the arriving heat radiation as well as possible and radiates indirectly on the inside to the parts surfaces.

The rotating basket and the parts must consist of materials with good thermal conductivity so that the rotating basket can transfer the arriving radiation heat not only by radiation inward as black body but also via direct tactile contact to parts surfaces.

The lower the temperature of the above surfaces due to the cooling of the evaporation heat removed from them, the slower the evaporation (only still the vaporisation for deeper cooling) of the rinsing medium in the vacuum.

It follows from this that

1. the cleaning chamber outside wall heater must be switched on for the process of parts cleaning with vacuum drying,
2. the basket in Dry2 must be programmed as slowly rotating ( $\leq 5$  rpm) to expose all rotating basket areas, particularly in the area of the 2 heater elements, to the outgoing radiation heat from the inner wall,
3. in addition to the resistance to chemicals, rotating baskets should have
  - a material surface resembling an ideal black body,
  - a material with good thermal conductivity and
  - a material with high heat capacity
4. the unheated and therefore comparably colder cover of the cleaning chamber with its cover seal is a place favouring condensation of media vapours; therefore the cover and its seal must be wiped dry from time to time with a clean lint-free paper / cloth.
5. Parts with plastic surfaces usually require a longer drying time and special vacuum parameters.

Under consideration of the elementary physical boundary conditions of the vacuum drying described above, selection of the vacuum drying parameters, adjusted for the respective drying task, of the sequence Dry2 (*Fig. 16.6*) using Expert Mode is recommended.

This is described in more detail below after a short explanation of the programmed vacuum drying parameters:

The programmable vacuum drying parameters in the sequence *Dry2* (*Fig. 16.6* bottom right) determine the

- further duration of the evacuation, measured from reaching the specified pressure (8 seconds, 120 mbar in *Fig. 16.6*), with which even lower pressures on the pressure-time curve  $p(t)$  in the cleaning chamber are reached when the vacuum pump is running,
- duration of the re-aeration by opening the vent valve of the cleaning chamber for the ambient normal pressure (2 seconds in *Fig. 16.6*) while the vacuum pump continues running (for the purpose of maintaining the flow of the supported vapour mist extraction for the cleaning chamber),
- number of repetitions of this cycle of evacuation and re-aeration (12 times in *Fig. 16.6*).

It was established during tests of the vacuum drying that the drying is accelerated in most cases if some short cycles with evacuation only up to 600 mbar and 2 seconds re-aeration for the purpose of additional vapour mist extraction with generated flow through the cleaning chamber are inserted after each re-aeration.

Therefore, three program-independent 600 mbar short cycles are performed after each programmed cycle.

**Example** Compact metal parts, however partially with cavities in hollow spaces (also pipes with wall thickness in the internal diameter area) are still wet after the standard drying with 12 cycles of 8 seconds each at 120 mbar.

The heat capacity here is usually sufficient to pass to a lower number of, yet longer duration, cycle to achieve lower pressures – for example:

3 cycles, 8 seconds – after reaching 55 mbar.

If the monitoring of the drying behaviour in accordance with the suggested process in this example results in cycle 2 having a shorter time than cycle 1 until reaching 55 mbar and cycle 3 needs even shorter time than cycle 2 for this, the concept of lower pressures for fewer cycles however longer time duration is correct for the first cycles.

This is usually the case for rinsing media with low boiling points such as IPA.

If no shortening of the time needed for reaching 55 mbar is observed in the third cycle, the number of cycles must be initially gradually increased – from 3 to 4 or 5.

If this shows that no shorter overall drying time than with the parameters in the standard program is achieved, drying must be performed in comparison with the standard program with only slightly reduced pressure (for example, from 120 to 100 mbar) and initially the same number of cycles.

If dry parts are obtained in this way, then reduce the number of cycles gradually without further reduced pressure.

This procedure is usually correct for rinsing media with high boiling points such as elma suprol pro or others with flashpoint >23 °C.

The first procedure shown in the example requires that the parts, due to their still sufficiently large heat capacity as compared with the evaporation heat of the last rinsing medium, do not need frequent reaeration with ambient temperature air for their heating.

Additional heating by means of frequent reaeration with ambient temperature air is used for the second procedure. This is needed for the drying of parts and/or baskets with low heat capacity.

### 16.3.3 Rinsing medium and parameters of the vacuum drying

The evaporation heat and the boiling point of the last rinsing medium are essential for the drying duration; they determine its dependency of the vapour pressure on the temperature  $p_v(T)$ .

Media are required for the (ultrasonic) cleaning and the (ultrasound-supported) rinsing steps that still do not boil during the necessary vacuum < 125 bar and maximum permissible media heating to 45 °C for explosion safety (warning is output if 40 °C is exceeded).

If rinsing is not ultrasound-supported in the last rinsing medium or heating of this rinsing medium to > 30 °C can be prevented in another way (cooling pauses), media with boiling points under 100 °C such as IPA (isopropanol, 2-propanol) can also still be used at normal pressure (*chapter.8.1*).

IPA boils at 82 °C under normal pressure of 1013 mbar, at 25 °C when reaching a vacuum of approx. 60 mbar and already at 30 °C when reaching approx. 80 mbar (*Fig. 16.7*).

When using IPA as the last rinsing medium, a pressure for the lowering of the pressure to be programmed in Dry2 can be selected at which the rinsing medium already boils and thus the evaporation and therefore the drying are very greatly accelerated due to the boiling.

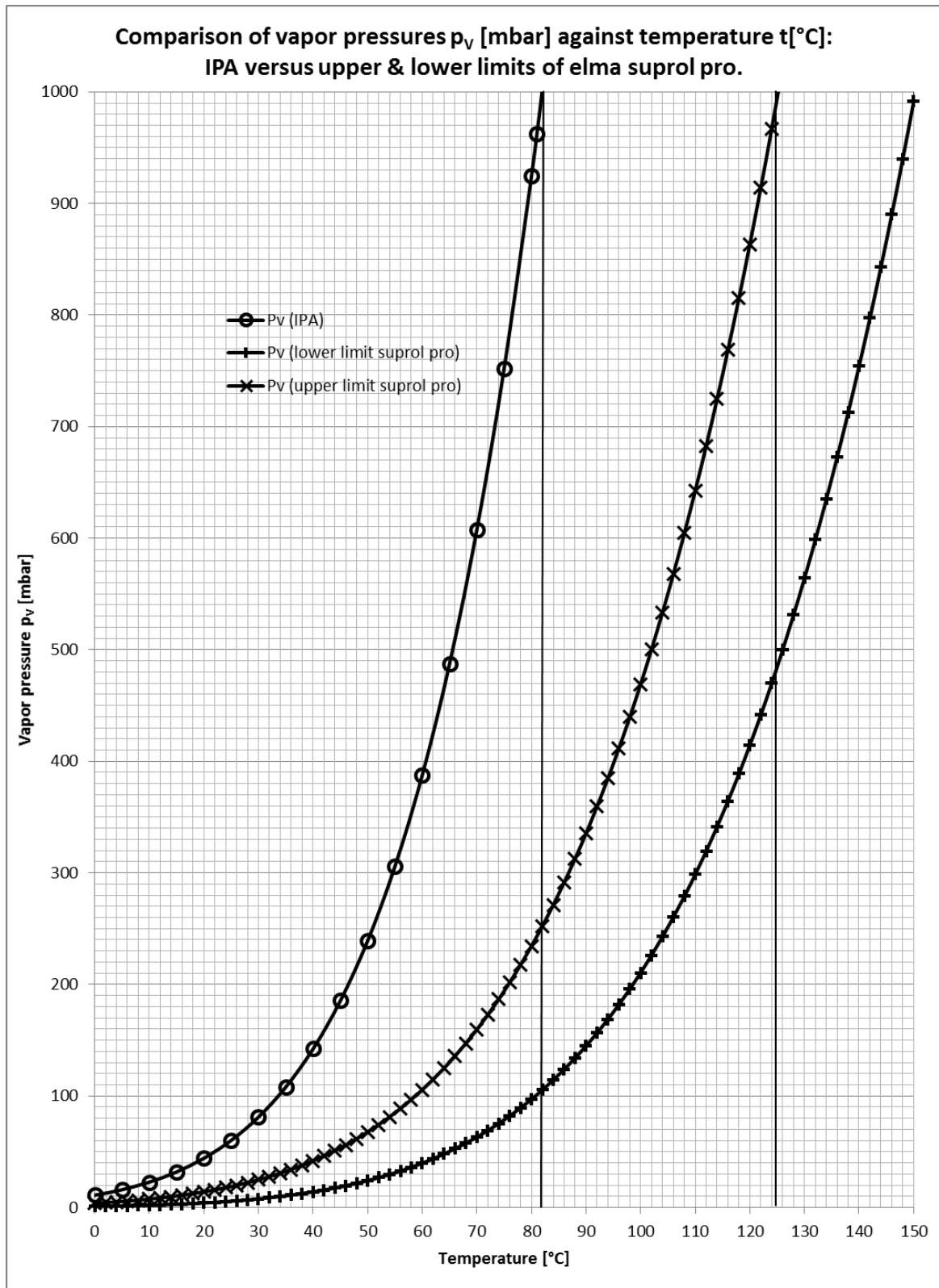

Fig. 16.7: Comparison of the vapour pressure dependencies on the temperature for IPA (isopropanol, 2-propanol) and the elma suprol pro hydrocarbon mixture. The latter should be considered between the vapour pressure curves of its two components with the lowest and highest vapour pressure.

However, the lowest boiling (i.e. first evaporating at continued temperature increase or pressure reduction) component (comparable with n-octane) of the elma suprol pro rinsing medium boils under normal pressure of 1013 mbar at 125 °C, at 30 °C when reaching a vacuum of approx. 25 mbar and at 40 °C when reaching approx. 40 mbar (*Fig. 16.7*).

However, the highest boiling (i.e. last evaporating at continued temperature increase or pressure reduction) component (comparable with n-nonane) of the elma suprol pro rinsing medium boils under normal pressure of 1013 mbar at 151 °C, at 30 °C when reaching a vacuum of approx. 10 mbar and at 40 °C when reaching approx. 15 mbar (*Fig. 16.7*).

The elma suprol pro rinsing medium, like other transportable rinsing media by road, rail and air as flammable liquids at still reasonable costs, must not undercut a flashpoint of 23 °C. Unfortunately, this does not allow any higher content of low boiling point and lower content of high boiling point components in the mixture.

This results in only a slower evaporation process than the boiling makes possible – the vaporisation of the rinsing medium – when using elma suprol pro as last rinsing medium with the available vacuum down to 25-30 mbar in the elma solvex VA.

Therefore, under the restrictions mentioned above and in *chapter 8.1* regarding heating of the rinsing medium using ultrasound for short drying times, the use of IPA as last rinsing medium is recommended although it has somewhat higher evaporation heat than the hydrocarbons in elma suprol pro.

## 17 Appendix 4: Expert Mode

### 17.1 Elmasolvex VA Expert Mode

In addition to its standard mode for creating and modifying cleaning programs, the Elmasolvex VA also provides an expert mode. This mode offers advanced configuration options and allows the user to adapt the cleaning steps more accurately to suit individual requirements.

The process steps for cleaning and rinsing can be divided into five sub-steps each.

The first four steps run a number of subsequent liquid-based cleaning settings. Upon completion of the fourth sub-step, the liquid is drained.

The fifth sub-step is always executed without liquid. Here you can also set parameters for spinning.

The drying process can be divided into two sub-steps.

The actual drying function is achieved through the radiant heat of the heating and several vacuum & aeration cycles in the chamber.

These parameters can be selected in the second sub-step of the drying process.

The first sub-step is used to add spinning/oscillation or rotation before the vacuum/aeration cycles.



If the duration of a sub-step is specified as 0 min 0 s, it is skipped.

All the process steps can be modified, which means that any changes may adversely affect the efficiency of the cleaning process. The enclosed handling instructions form the basis for a qualified adjustment of the cleaning parameters.

## 17.2

### Creating your own cleaning programs

It is possible to create up to 13 additional cleaning programs of your own. You may create cleaning programs in accordance with your own requirements in any of the following ways:

- Create a new cleaning program  
Recommended procedure to create a program with completely new parameters.
- Create new cleaning program based on a copy of an existing cleaning program  
Recommended procedure if you would like to copy an existing program and make it available in addition to the original program with just a few parameter changes.
- Modify an existing cleaning program  
Recommended procedure if you would like to modify the parameters of an existing program.

The factory-set predefined cleaning programs cannot be modified or deleted.

Programs which you create yourself may be copied, modified or deleted at any time.

You can also delete (your own) existing cleaning programs.



Factory predefined cleaning programs are shown on the display with a blue background. Your own cleaning programs have a green background. The selected cursor field has a brown or grey background.

**Procedure** On the display screen, select *Program Selection*  (Fig. 7.2.1).

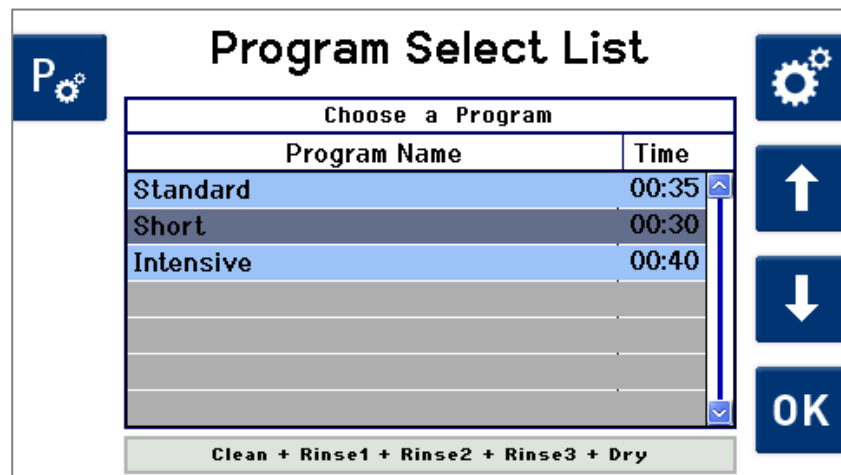

Fig. 7.2.1 *Program Selection* display

The *Select/Change Programs* display appears (Fig. 7.2.1.1).

## 17.3

## Creating a new cleaning program

Proceed to select on of the options on the *Create/Change Programs* display.

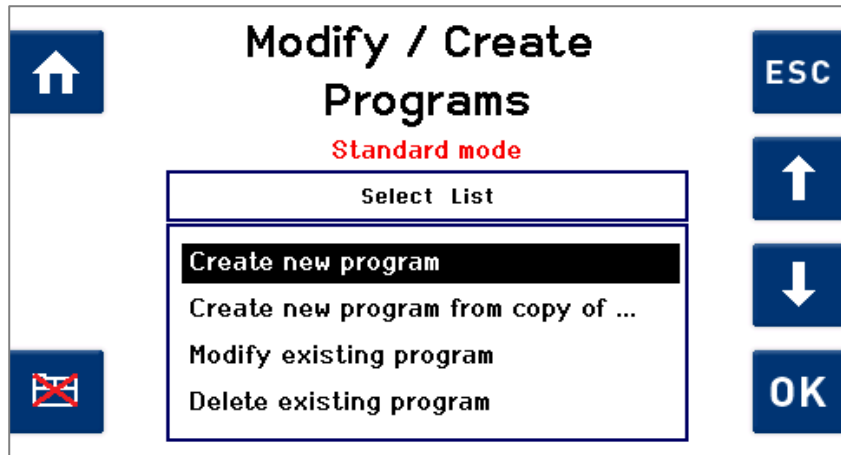



Fig. 7.2.1.1 *Create/Change Programs (standard mode) display*

Press the  button to activate expert mode.

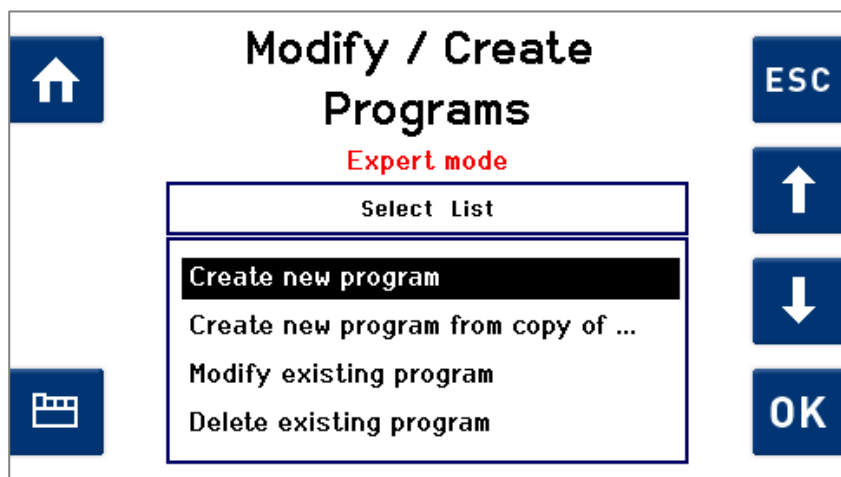







Fig. 7.2.1.1b *Create/Change Programs (expert mode) display*

Use  /  in the selection list to select *Create New Program*, and confirm with  (Fig. 7.2.1.1b)

The *Enter Program Name* (Fig. 7.2.1.2) display appears.

### Naming the new program

Navigate within any line of the character selection using  / .

Use  /  to navigate between the 3 lines.

Use the  button to delete any character that you entered.

Press  to apply the selected character.

To save the entered program name and continue to specify program parameters, press .

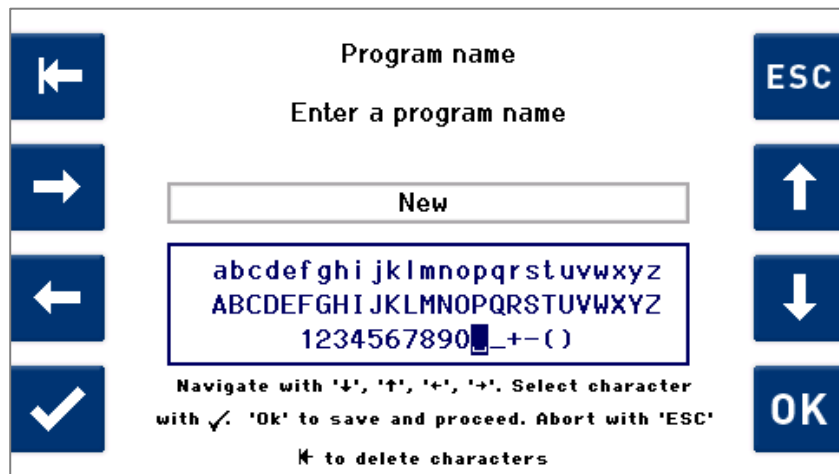

Fig. 7.2.1.2 Enter program name

**Specifying/changing program parameters**

The initial display screen allows the user to navigate between the tabs for the individual process steps (Fig. 7.2.1.3).

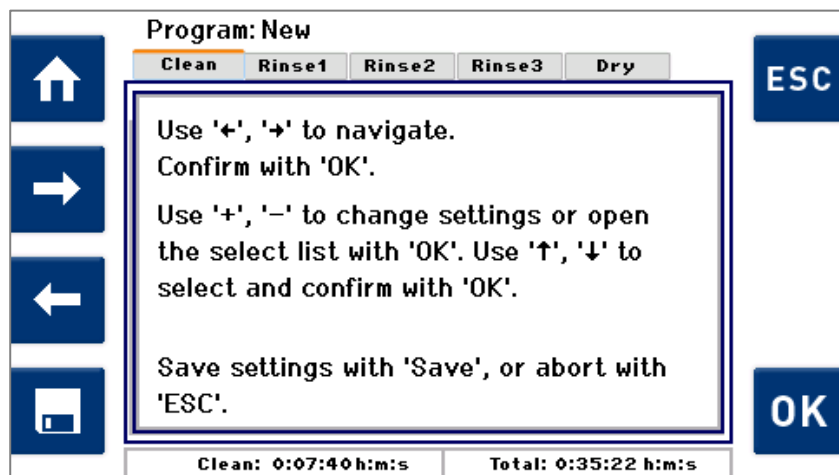

Fig. 7.2.1.3 Display screen – tabs with individual process steps

Use <left> / <right> to navigate between the tabs.

Press <ok> on the *Cleaning* tab to display sub-steps for cleaning (Fig. 7.2.1.4).

**Specifying/changing the *Cleaning* parameters**

Navigate through the sub-steps of the *Cleaning* process parameters in the same way as you navigate through the tabs of the entire cleaning program.

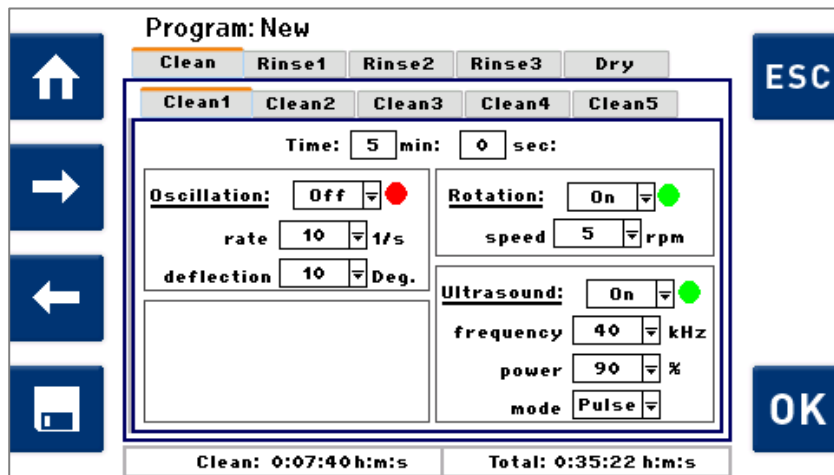

Fig. 7.2.1.4 Display screen – process step *Cleaning*

Press **OK** on the *Cleaning1* tab to be able to modify the process parameters for this process step. Use **←** / **→** to navigate between the parameters. Press **+** / **-** to change the preset values. Use **☑** to save changes at any time. When you have made the desired changes, press **ESC** to return to the display screen with the process step tabs (Fig. 7.2.1.3). You can also press **⬆** to return to the *Program Selection* display.

If you did not save your changes by pressing **☑**, you will be prompted to save any changes when you press **ESC** / **⬆** (Fig. 7.2.1.5).

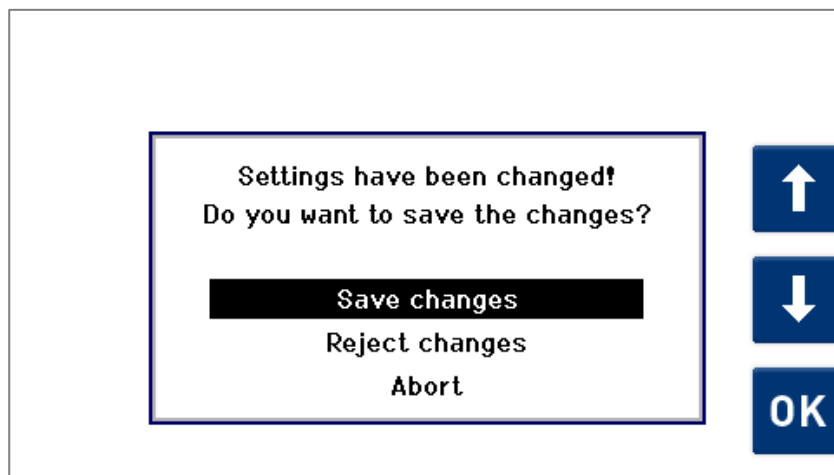

Fig. 7.2.1.5 *Save Settings* display

Use **↑** / **↓** in the selection list to select the required action, and confirm with **OK**.

Use *Save Changes* to save any amended settings and return to the *Program Selection* display.

Use *Discard Changes* to return to the *Program Selection* display without saving your changes.

Use *Cancel* to return to the previous display screen.

## 17.4

### Creating a cleaning program from a copy

#### Selecting a program for modification

In the *Create/Change Programs* display (Fig. 7.2.1.1) use **↑** / **↓** to select *New Program from Copy*, and confirm with **OK**.

Use **↑** / **↓** to select the cleaning program which you want to copy and modify (e.g. *Standard*).

Confirm your selection with **OK**.

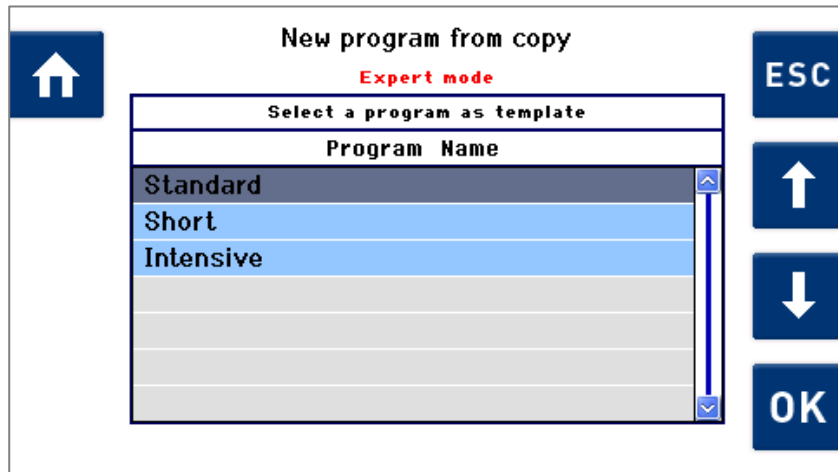

Fig. 7.2.2.1 *New Program from Copy* display

#### Naming the new program

After you have selected the cleaning program to be copied, the *Program Name* display appears (Fig. 7.2.2.2).

The field for the program name initially contains the field for the program name with a number, such as *\_0*. You can change the name as desired.

To save the program name and continue to specify program parameters, press **OK**.

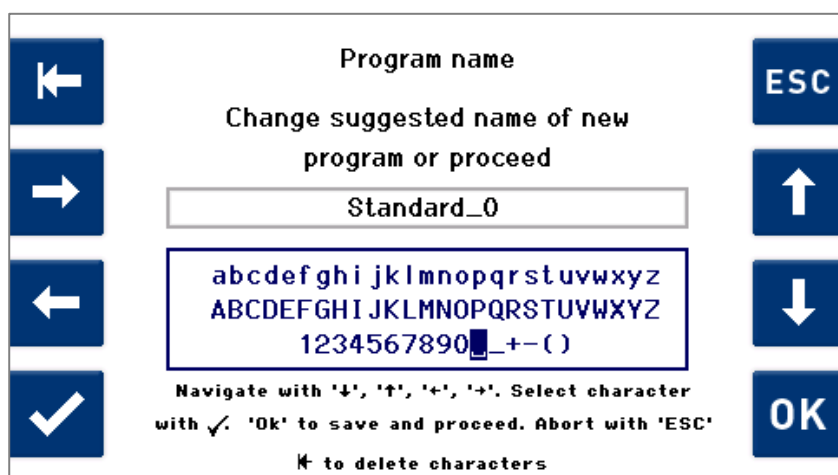

Fig. 7.2.2.2 *Program Name* display

#### Editing program parameters

After you enter the program name, the display screen with the program parameters for *Cleaning* appears (Fig. 7.2.1.3).

You can now modify the existing program parameters of the copied cleaning program to suit your requirements.

Use the same procedure as described previously.

## 17.5 Modifying an existing cleaning program



You cannot modify the factory-set predefined cleaning programs.

Programs which you create yourself may be copied, modified or deleted at any time.

In order to change a factory predefined cleaning program, it must first be saved as a copy (*as described above*).

If no other cleaning program apart from the standard programs is available and you select *Change Existing Program*, a message appears to say that no modifiable program has been found.

### Procedure

In the *Create/Change Programs* display (*Fig. 7.2.1.1*) use **↑** / **↓** to select *Change Existing Program*, and confirm with **OK**.

The *Change Program* display appears and shows the existing cleaning programs (*Fig. 7.2.3.1*).

### Selecting a program for modification

Use **↑** / **↓** to select the cleaning program for modification (*Standard\_0* in the example below) (*Fig. 7.2.3.1*).

Confirm your selection with **OK**.

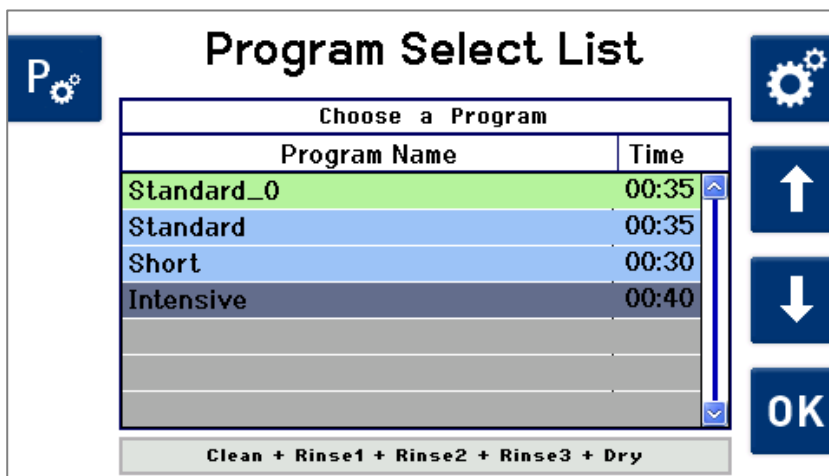

Fig. 7.2.3.1 *Change Program* display

### Renaming a program if required

After you select the cleaning program to be modified, the *Program Name* display appears (*Fig. 7.2.2.2*).

You can change the name as previously described or retain it. To save the program name and continue to specify program parameters, press **OK**.

### Editing program parameters

The initial display screen shows program parameters for the *Cleaning* process step (*Fig. 7.2.1.3*).

The existing program parameters of the cleaning program selected for modification can now be changed (overwritten) individually.



Use the same procedure as described previously.

## 17.6 Deleting a cleaning program

 The factory-set predefined cleaning programs cannot be deleted.

Programs you have created yourself can be deleted at any time.

**Procedure** In the *Create/Change Programs* display (Fig. 7.2.1.1) use  /  to select *Delete Existing Program*, and confirm with .

**Selecting a program for deletion** Use  /  to select the cleaning program for deletion (*Standard\_0* in the example below) (Fig. 7.2.4.1).

Confirm your selection with .

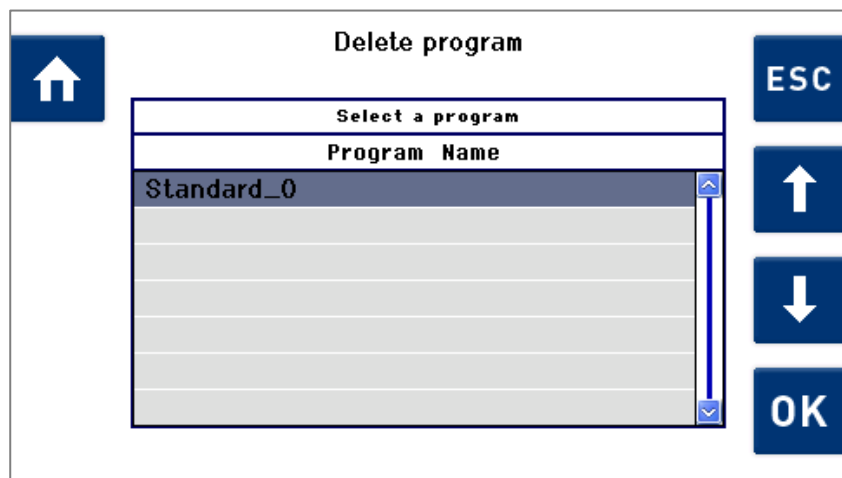



Fig. 7.2.4.1 *Delete Program* display

You are then asked if you really want to delete the selected program.

Press  to confirm the *Delete Program* command.

If you want to discard the command, press .

Both actions will return you to the *Delete Program* display. You can now delete additional programs or return to the *Program Selection* display .

