



SHIRACLEAN

Ultrasonic Cleaning Equipment

Operation & Instruction Manual Model

TVT-033G

120 VAC 50/60 Hz, 20 A

Read all instructions thoroughly before operating this equipment

TABLE OF CONTENTS

Introduction.....	3
Warnings.....	4
Set-Up.....	5
General.....	5
Digital Temperature.....	7
Digital Timer.....	9
Filtration System.....	10
Cleaning Procedures.....	11
Machine Operation.....	11
General Cleaning.....	12
Equipment Maintenance.....	13
General.....	13
Tank Draining.....	13
Changing Filters.....	14
Limited Warranty	15
Trouble Shooting.....	16
Parts List.....	21

INTRODUCTION



About the Ultrasonic Cleaning Process

Congratulations! You have purchased a SHIRACLEAN Ultrasonic Parts Washer.

But how does Ultrasonic Cleaning work?

When ultrasonic energy is introduced into a cleaning solution, alternating patterns of low and high pressure phases occur. This process forms microscopic vacuum bubbles. During the subsequent high pressure phases, the bubbles implode violently. This is called cavitation.

Cavitation provides an intense scrubbing action that leads to an unsurpassed cleaning speed and consistency when compared with simple soaking or immersion with agitation. Additionally, the bubbles are small enough to penetrate even microscopic crevices, cleaning them thoroughly and consistently. As a result, ultrasonic cleaning is one of the most highly effective and efficient methods you can use for cleaning a wide array of items.

Tovatech provides a complete line of quality ultrasonic cleaning washers that have been developed for industries that have historically used technology that is quickly becoming outdated. While other companies use environmentally harmful cleaning solvents, we provide state-of-the-art, labor saving, fast, efficient and environmentally safe alternatives.

WARNINGS

Failure to read these warnings may cause the unit to fail, personal injury or property damage.

- Equipment should only be operated on a single phase, 120VAC, 20 Amp **grounded** electrical system. The plug is a Hubbell #5366C. A Hubbell #5361, or compatible, receptacle is required.
- Do not plug equipment into a power source that utilizes a GFI receptacle. Ultrasound passes a small, trickle current through the neutral which will cause GFI's to trip.
- Never plug in or operate the unit (heat, ultrasound or pump) without the appropriate liquid level in the tank (the height of the spray bar).
- Any detergents or chemicals used in this equipment must be compatible with 300 series stainless steel. Do not use any chemicals that contain any strong acids i.e. hydrochloric, sulfuric or muriatic acid. These chemicals will cause permanent damage to the stainless steel welds.
- Due to the heated liquid in the tank, use baskets, tongs or wires to insert or remove parts from the tank.
- Do not operate the unit with wet hands.
- Use only biodegradable cleaning agents. Never use solvents or flammable cleaning solvents without approval from Tovatech. Any chemistry with a flash point below 180°F should never be used with an ultrasonic cleaner.
- Do not rest parts to be cleaned directly on the radiating surface. Severe transducer erosion will occur. The tank rack must rest on the bottom.
- Do not open the internal circuitry of the equipment, disassemble any part or parts, or move or remove any components or electrical devices.
- Never attempt to perform maintenance on the equipment when the unit is energized or when the cleaning solution is hot.
- Disconnect the power source when moving the unit to a new location.
- Avoid splashing water outside the tank.

Only qualified technically trained personnel should perform any electrical maintenance on this machine.

SET-UP

General

- Place the machine on a level surface and lock the wheels located nearest the filters.



Locking Wheels

- Be sure the drain valves are completely closed (handles perpendicular to the drain) before filling the machine.



Weir Drain

Main Bath Drain

- Fill the wash tank with water (*see note at the end of this section*) and the proper dilution of soap to the top of the weir and make sure that the weir is 2/3 full. Using hot water will shorten the amount of time required to reach the desired temperature. Check drain assembly to insure that there is no leakage.
- The TVT-033G tank dimensions are 24" x 18" with a 14" liquid depth. This tank will hold 33 gallons and has a working volume of approximately 30 gallons. This liquid volume does not include the liquid in the overflow weir or the pump / filter system or the volume around the immersible transducer. Use this volume for calculating the amount of detergent you will use.



- If either the weir or machine tank do not have enough water the pump will be damaged and the machine will fail. Once the proper amount of water has reached the low level sensor, just below the spray bar, it will be activated allowing the machine to function properly.
- Plug the power cord into a proper electrical outlet and press green **POWER** button.
- Unlock the lid by pulling the hinge, located on the right side of the lid, towards yourself and close the lid over the tank to maximize insulation efficiency
- Set digital timer and temperature controls.
- The TVT-033G utilizes one (1) 900 Watt built-in silicone heating elements and is well insulated. The time required to heat the machine initially will vary between four (4) and six (6) hours. The unit heats water at approximately fifteen (15) degrees per hour. After the initial heating period, the temperature will remain constant with very limited electrical draw. It is important that the lid remain closed when not in use to minimize heat loss and evaporation.

****Note About Water****

The quality of your water source can have an important effect on the performance of the ultrasonic equipment. High levels of calcium, magnesium, sulfur and other contaminants in the water source can have a negative effect on the type of cleaning soap used. High levels of calcium and/or magnesium (constitutes hard water) can cause the soap to work less efficiently and less effectively as intended and can also leave a white, flaky residue on the parts once dried. If this white spotting occurs and is not desired, it will be necessary to use soft water, drinking water or distilled water, in the machine. The level of final cleanliness will dictate the water source used in the machine.

Digital Temperature

Knowing Your Temperature Controller



- PV: This upper display indicates the actual Process Value (or current temperature) of the bath and cannot be changed manually.
- SV: The lower display indicates the Set Value or desired bath temperature. This Set Value is adjustable.
- ALM 1: If this light is on, it means that the machine is currently heating. It will shut off once the desired temperature has been reached.
- OUT: If this light is on, it means that the bath temperature is out of the preset range of 50°F - 160°F. There is a 5° hysteresis which means that the heating mechanism (and the OUT light) will go on/off based on a 5° variance. This serves as a buffer to protect the life of the motor contactor.
- AT, ALM 2: Manufacturer use only.
- Return Key 

Operation

- The temperature controller is factory set at 150°F.
- To change the Set Value, lightly press the up arrow key to increase or lightly press the down arrow key to decrease the value. Pressing and holding down either arrow key will change the displayed value rapidly.
- Upon changing the Set Value, this lower display will flicker indicating the new value is not set. To make this value permanent, press the RETURN Key .
- Experience shows that the optimum ultrasonic cleaning temperature for most applications is 120°F - 160°F.
- When ready to activate the heat, turn the selector switch marked **HEAT** to the **ON** position.
- The heat circuit and the ultrasound can be operated simultaneously.

If increased or decreased security is desired, please contact technical support at Manufacturer to receive instructions.

Digital Timer

Operation

- The 4-digit number on the upper display is the amount of time that the machine has been in actual operation. It will count up to the preset value.
- The illuminated 4-digit number on the lower display is the preset value.
- Pressing the **RESET** button will deactivate the timer and reset it to 0. Turning the switch to **RESET** will also deactivate the timer.
- Pressing the **LOCK** button will prevent you from changing the preset time value. **LOCK** will display in the lower orange display.
- The ultrasound is factory set to 15:00 minutes.
- To adjust the preset value, press the blue keys. Press the up arrow key, to increase, or down arrow key, to decrease.
- Left most blue key corresponds to 10 minute increments.
- Second blue key from the left corresponds to 1 minute increments.
- Third blue key from the left corresponds to 10 second increments.
- Right most blue key corresponds to 1 second increments.
- The time is activated by turning the selector switched marked **SONICS** to the **ON** position. The button will return to center. The “OP” light will illuminate on the lower, left side orange display. A red light will illuminate and blink on the upper, left side red display while the timer is operational.



Filtration System

- In many applications the use of a pump and filtration system will extend the useful life of the cleaning chemistry.
- The spray bar pushes the water surface over the weir, skimming off floating oil and debris that is loosened by the ultrasonic cleaning.
- The filtration system will then remove water from the weir tank, pass it through the dual filters and spray the filtered water back into the wash tank through the spray bar.
- The pump and heat circuits can be operated simultaneously.
- However the pump will not operate while the ultrasound is in use. Doing so would decrease the cavitation cleaning effects of the ultrasound.
- How often you use the pump is dependent on what is being cleaned and the state of the water (i.e. if the items are oily, then the pump should be run after each cleaning cycle).
- To activate the filtration system, turn the selector switch marked **PUMP** to the **ON** position.

CLEANING PROCEDURES



Machine Operation

- If you haven't done so already, press the green button marked **POWER**. The button will illuminate. The control panel is now energized.
- To activate the ultrasound, turn the switch marked **SONICS** to the **ON** position. The selector switch will spring back to the center position.
- Before cleaning your first batch of items, operate the ultrasound for fifteen (15) minutes. This process is called degassing and helps eliminate any air from the water in the tank.
- To deactivate the ultrasound before the timer has completed its cycle, turn selector switch to the **RESET** position. The selector switch will spring back to the center position.

General Cleaning

- Be careful not to overload the system and/or the baskets.
- Many times you can achieve better results by cleaning two smaller loads rather than one large load.
- Baskets should be made from round stock (rod) whenever possible, rather than flat stock that would reflect the ultrasonic energy.
- When lowering the items into the tank via baskets or tongs, be sure to arrange the items so they are not touching the bottom of the tank. They should be suspended at least ½" above the tank bottom. This can be achieved with the use of a tank rack.
- Items should not be stacked too densely.
- The volume of parts to be cleaned should not exceed thirty percent (30%) of the total tank volume.

- Once the timer has been set, activate the ultrasound by switching **SONICS** to **ON**.

- Cleaning times will vary depending on the temperature of the solution, the number of parts to be cleaned, the amount of contamination and the amount and type of cleaning agent used. Generally, small parts should be cleaned with the ultrasound operating for three (3) to five (5) minutes.

- While the parts being cleaned do not require continuous supervision or labor intensive cleaning, they should be inspected during the cleaning process.

- After the timer has cycled off, remove the items via basket and rinse them.

- Visually inspect each item for desired decontamination after the parts have dried completely.

- If parts must be handled, wear gloves when touching surfaces to protect against heated items

EQUIPMENT MAINTENANCE

General

- Keep the bath free of oils, grease and any foreign materials.
- Skim off oil and grease residue periodically, if necessary.
- Cleaning agents should be changed periodically depending on usage.

Draining Tank

- Turn equipment off and unplug the power cord.
- Wait at least twenty (20) minutes after the heat circuit is turned off before emptying the tank. Permanent damage to the heater elements will occur if the tank is drained too soon after the heaters are turned off.
- Drain the contaminated cleaning solution from the tank using both valves.
- Rinse the inside of the tank with clean water.
- Buff the inside of the tank with a clean, soft cloth. Do not use steel wool cleaning pads as they are too abrasive and will scratch the tank surface.
- Rinse the tank again.
- If the tank will not be used for a long period of time, wipe the inside and the outside of the tank dry with a dry, clean, soft cloth.
- Close the lid on the cleaning tank. The lid should remain closed when the equipment is not in use to keep dust and debris from accumulating.
- This tank cleaning procedure should be performed every time the bath is changed. Always thoroughly inspect drain areas for leaks.

When discharging bath and waste, follow all environmental and regulatory requirements. A reputable and licensed waste transportation firm should perform removal of all waste materials. Manufacturer is not liable for improper handling of waste materials.

Changing Filters

Disposable

- Prior to changing the filters, the water level in the tank must be no higher than the level of the spray bar and the water in the canisters must be cool before opening to avoid burns from the hot liquid inside the canister.
- Filters should be changed periodically depending on the usage of the equipment and the contaminants being removed. If water is not flowing more than a trickle from the spray bar holes, it is time to replace your filters.
- Individually unscrew counterclockwise the two (2) large blue filter cartridge holders. The cartridges will be full of water.
- Pour the water out of the cartridges and remove the filters. Be careful not to lose the rubber O-ring gasket located on the inside of the filter cartridge. Absence of this gasket will cause the filter(s) to leak.
- Replace with new filter(s) and re-install the cartridges.
- The 30 Micron Polycarbonate Filter is the primary filter and is located on the right side of the filtration unit.
- The Carbon Filter is the secondary oil filter and is located on the left side of the filtration system. The Carbon Filter removes oil and grease and will require changing more often than the 30 Micron Polycarbonate Filter.

Reusable Stainless Steel

- Clean the outside of the filters in a sink.
- Place each filter into individual Ziplock bags.
- Fill each bag with hot water and add soap from the bath.
- Seal bag and place into ultrasonic tank and operate the ultrasound for 15 minutes.
- Dump the fluid from the bag into the sink, NOT the ultrasonic tank.
- Repeat the process until no dirt is extracted from the filters.
- Replace the filters into the blue canisters.

LIMITED WARRANTY

Manufacturer warrants the TVT-045G ultrasonic cleaner for a period of two (2) years from the date of delivery, when used in accordance with the manufacturer's instructions. During the warranty period, Manufacturer will repair or replace free of charge at an authorized repair service center all parts that are defective because of material or workmanship. Freight charges to an authorized service centers are the responsibility of the user.

This warranty does not include damage or product failure, which results from cavitation erosion, misuse, abuse or transportation damage. This warranty is limited to the original purchaser and is not transferable. Total liability for any reason whatsoever, shall not in any case exceed the cost of repair or replacement of the defective part. In no case shall Manufacturer be responsible for any incidental or consequential damages.

Tovatech LLC
2512 Summit Avenue, Suite 305
Plano, TX 75074

www.tovatech.com

TROUBLE SHOOTING

Isolate the exact issues(s) you are experiencing by following the following procedure.

1. Turn off Ultrasound
2. Turn off Heat
3. Turn off Pump
4. Leave Green Power push button pressed in and illuminated.
5. Turn on Pump – Does it operate?
6. Turn off Pump
7. Turn on Heat – Does it operate?
8. Turn off Heat
9. Turn on Ultrasound – Does it operate?
10. Turn off Ultrasound

Control panel has lights, but there is no Ultrasound, Heat or Pump action.

1. Is the water level to the middle height of the spray bar?
2. If NO - fill water to the appropriate level.
3. If YES- check the float located under the spray bar, towards the back of machine.
4. If the float is stuck in the down position, toggle it up.
5. Preventative maintenance is to clean the pivot point where the float connects to the body.
6. If the float is up and water is in the tank to the middle of the spray bar.
 - a. Unplug the machine from the facility power supply.
 - b. Remove upper panel located on the right end of the machine.
 - c. Look for the ice cube relay located at the left end of the back panel.
 - d. Flip the window up (window has a red button) – this bypasses the float.
You will see an orange flag visible in the upper right window.
 - e. The machine will be operational, but will have no low water level protection.
 - f. Replace the defective float switch.
7. Machines manufactured prior to 2013, will not have this relay option.
 - a. Locate the looped wire terminating into a two pin connector.
 - b. Unplug the two connectors that the looped wire is threaded through.
 - c. Plug the looped wire into the open mating connector.
 - d. The machine will be operational, but will have no low water level protection.
 - e. Replace the defective float switch.
8. If either instruction 6 or 7 does not solve the issue, replace ice cube relay.
9. Contact Manufacturer to order a replacement ice cube relay.

The Pump is not operational.

1. Turn on the Pump and listen for the sound of the motor spinning.
2. Note: Pump motor is located on the left end of the machine under the blue canisters.
3. Put your hand near the back of the pump motor and feel for any air flow.
4. If you feel air flow, or feel motor vibration or hear the motor humming, follow steps a-f.
 - a. Unscrew each blue canister and remove the filters completely.
 - b. Place the filters in a sink or away from the machine and keep track of orientation.
 - c. Note: Make sure to not lose black O-ring from blue canister or leaks will occur.
 - d. Screw blue canisters back on.
 - e. Turn on Pump and wait several minutes to see if water moves through spray bar.
 - f. If you have water flow, the filters are clogged and must be replaced.
5. If you are using stainless steel reusable filters, follow 5a - 5g.
 - a. Clean outside of filters in a sink.
 - b. Place each filter into individual Ziplock bags.
 - c. Fill each bag with hot water and add soap.
 - d. Seal bag and place into ultrasonic tank and operate ultrasound for 15 minutes.
 - e. Dump the fluid from the bag into a sink – not into the ultrasonic tank.
 - f. Repeat this process until no dirt is extracted from the filters.
 - g. Replace filters into the blue canisters.
6. If you do not have water flow without filters and the motor is operational, follow 6a - 6c.
 - a. Drain tank and remove the pump head volute from motor.
 - b. Inspect the impellor and shaft to see where the damage is.
 - c. Replacing the Pump Head less Motor is the likely solution.

No lights on the control panel.

1. Is the Power push button pushed in?
2. Is there power to the facility outlet?
3. Turn off Power and unplug the machine.
4. Remove upper panel located on the right end of the machine.
5. Is the circuit breaker energized (UP-Red) or (DOWN-Green)?
6. If the circuit breaker is tripped, re-set the circuit breaker.
7. Plug in machine.
8. Follow the steps above in "Isolate the exact issue".
9. Machines manufactured after January 2015 have panel fuses and may be burnt. If either of the fuse holder red lights are lit, the 5 amp fuse(s) must be replaced.

Heat is causing the circuit breaker to trip.

1. Likely cause is a shorted heat blanket.
2. Remove the front (if applicable) and back lower access panels.
3. Inspect the heat blanket(s) – they should be an orange/ pinkish color.
4. If the heat blankets are black or charcoal white, they must be replaced.
5. Call Manufacturer to order new heat blanket(s).

Pump is causing the circuit breaker to trip.

1. Likely cause is a faulty or shorted motor.
2. The timer could also be shorted, but the display will not display properly.
3. Call Manufacturer to order a new pump.

Ultrasound is causing the circuit breaker to trip.

1. Remove lower vented/ panel located on the right end of the machine.
2. Remove the power plug from the back of each generator.
3. Activate the ultrasound.
4. If the circuit breaker trips again, then the corrective action is to replace the digital timer.
5. If the circuit breaker does not trip, then follow these procedures.
 - a. Plug in one generator at a time to isolate which exact generator is causing issue.
 - b. Contact Manufacturer to have the existing generator repaired or replaced.
6. If no specific circuit causes the internal circuit breaker to trip but the issue occurs sporadically, then the circuit breaker will need to be replaced.
7. Call Manufacturer to order a new circuit breaker.

Ultrasound circuit is not operational.

1. Does the digital timer have a visible display?
2. Does the timer count up?
3. Does the timer display flash "OP." in the lower left side?
4. Does the timer display flash a RED dot in the upper left side?
5. If the answer to 1 -4 is NO, replace the digital timer.
6. If the answer to 1, 2 or 3 is YES, use the following steps.
7. Remove upper panel located on the right end of the machine.
8. Does the center coil on the Ultrasound contactor pull in when timer activates?
9. If the answer is YES, the generator is the likely cause.
10. If the answer is NO, can you manually push in the coil to activate the ultrasound?
 - a. NOTE: Use an insulated screwdriver to push in the center coil.
 - b. If you cannot push in the coil manually, the contactor needs to be replaced.
11. Contact Manufacturer for a generator RMA or to order a replacement contactor.

The unit trips the GFCI circuit breaker when the ultrasound operates.

1. GFCI circuit breakers will cause intermittent trips with ultrasound.
2. Install non-GFCI circuit breaker.

NOTE: Always inspect the back panel wires for burnt or loose wires. Burnt wires are typically caused by a loosened connection and must be replaced.

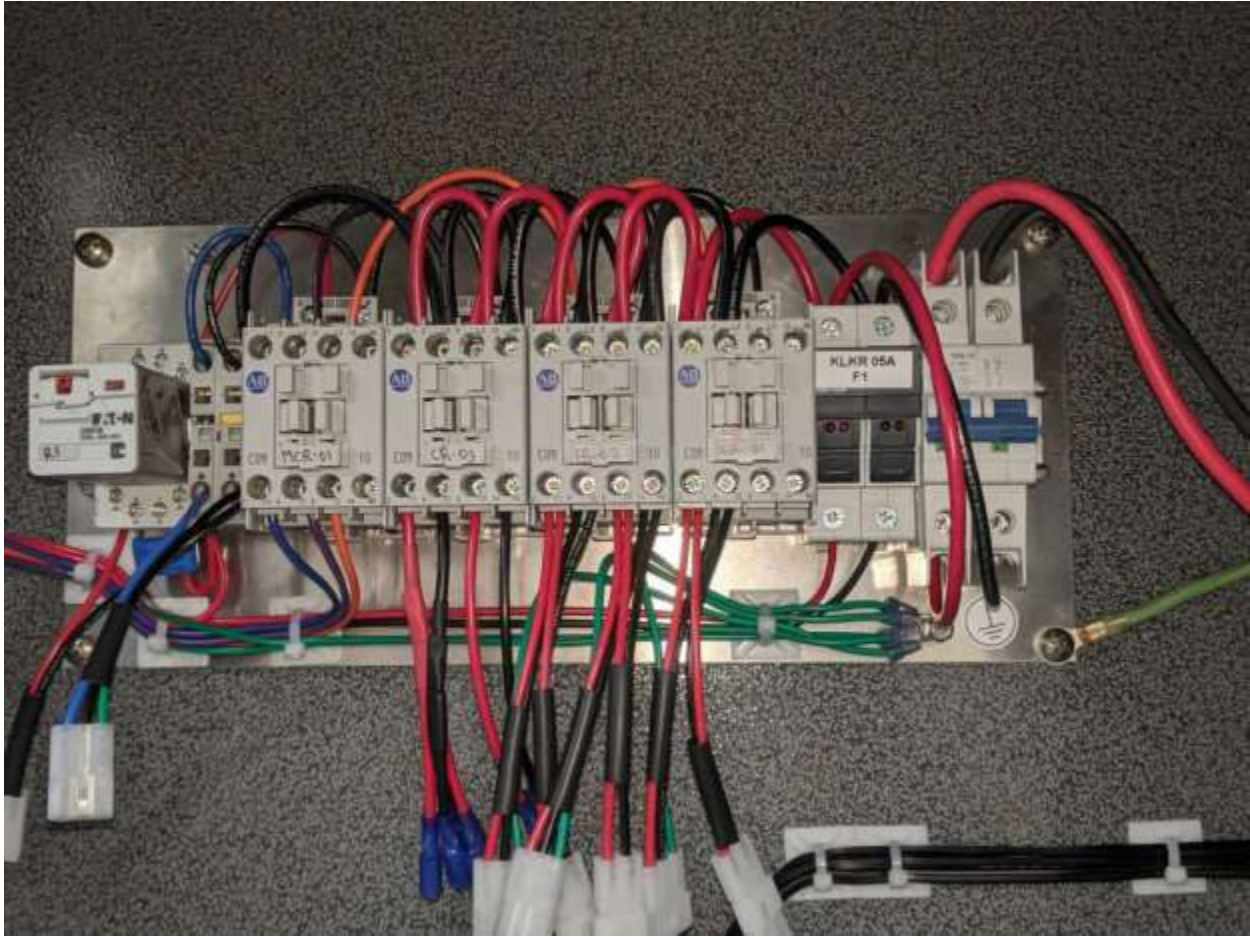

Float Sensor
Ice Cube Relay

Power
Contactor

Heat
Contactor

Sonics
Contactor

Sonics
Contactor

Fuse
Holder

Circuit
Breaker

PARTS LIST

- Pump - *Pump-MD3120*
- Float Sensor – *Float Sensor*
- Generator (3) – *OMG-9002-40U*
- Transducer (3) – *IM4014x16-2000*
- Digital Timer - *Timer*
- Digital Temperature Controller – *Digital Temp*
- 3 Position Selector (“Sonics”) – *Switch-3 Position Selector*
- 2 Position Selector (“Heat” and “Pump”) – *Switch-2 Position Selector*
- Power Button – *Push Button*
- Motor Contactor – *Contactor-120*
- Heat Blanket – *Heat Blanket-900/120V*
- Ice Cube Relay - *Relay-120*
- 30 Micron Filter - *OMG Filter 30*
- Carbon Oil Filter - *OMG Filter Oil*