



VESTIL MANUFACTURING CORP.
 2999 North Wayne Street, P.O. Box 507, Angola, IN 46703
 Telephone: (260) 665-7586 -or- Toll Free (800) 348-0868
 Fax: (260) 665-1339
www.vestilmfg.com e-mail: sales@vestil.com

D & H-SERIES HOPPERS

Instruction Manual

Distributed By:



2717 Tobey • Indianapolis, IN 46219
 (317) 545-0665 • FAX (317) 545-0670 • (800) 800-0665
www.idsblast.com



D-SERIES HOPPERS



H-SERIES HOPPERS

RECEIVING INSTRUCTIONS:

After delivery, IMMEDIATELY remove the packaging from the Hook-Base in a manner that preserves the packaging and maintains the orientation of the product in the packaging; then inspect the product closely to determine whether it sustained damage during transport. **If damage is discovered during the inspection, immediately record a complete description of the damage on the bill of lading.** If the product is undamaged, discard the packaging.

NOTES:

- 1) Compliance with laws, regulations, codes, and non-voluntary standards enforced in the location where the product is used is exclusively the responsibility of the owner/end-user.
- 2) VESTIL is **not liable** for any injury or property damage that occurs as a consequence of failing to apply either:
 - a) Instructions in this manual; or
 - b) Information provided on labels affixed to the product. Neither is Vestil responsible for any consequential damages sustained as a result of failing to exercise sound judgment while assembling, installing, using or maintaining this product.

Table of Contents

Product Introduction..... 2 – 4
 Safety Principles..... 8
 Safety Recommendations..... 8
 Loading instructions..... 9
 Use & Operation Instructions..... 9
 Inspections & Maintenance..... 10
 Limited Warranty..... 13

Table of Figures

Fig. 1 H-series hoppers diagram and parts list 5
 Fig. 2 D-series hoppers diagram and parts list..... 6
 Fig. 3 Leak proof H-hopper & parts diagram..... 7
 Fig. 3 H-series markings & label placement diagram..... 11
 Fig. 4 D-series markings & label placement diagram..... 12

Product specifications:

Thank you for purchasing a fork-mountable, self-dumping hopper made by Vestil Manufacturing Co. ("Vestil"). Our hoppers are durable, high-quality products that incorporate safety-enhancing features. Standard design features include: 2 fork pockets that receive the tines (forks) of a fork truck; dump-actuating cable that allows the hopper to be dumped by the forklift driver; and either a safety chain or safety strap to wrap around the carriage of a fork truck and prevent the hopper from sliding off of the forks during use. Dimensions and other specifications appear in the following table:

Model	Volume in Cubic Yards (m ³)	Uniform Maximum Rated Load in Pounds (kg)	Overall Dimensions (W x D x H) in Inches (cm)	Distance between Fork Pocket Centers in Inches (cm)	Net Weight in Pounds (kg)
H-series hoppers (low profile 90° self-dumping steel)					
Light duty (12 gauge steel)					
H-25-LD	$\frac{1}{4}$ (~0.19 m ³)	2,000 (~909kg)	25 x 46 x 18 ~(63.5 x 116.8 x 45.7)	11-5/8 (~29.5cm)	219 (~99.5kg)
H-50-LD	$\frac{1}{2}$ (~0.38 m ³)	2,000 (~909kg)	25 x 51 $\frac{1}{4}$ x 28 ~(63.5 x 130.2 x 71.1)cm	11-5/8 (~29.5cm)	256 (~116.4kg)
H-100-LD	1 (~0.76 m ³)	2,000 (~909kg)	49 x 51 $\frac{1}{4}$ x 28 ~(124.5 x 130.2 x 71.1)cm	21-5/8 (~55cm)	347 (~157.7kg)
H-150-LD	1 $\frac{1}{2}$ (~1.15 m ³)	2,000 (~909kg)	49 x 52 x 40 ~(124.5 x 132.1 x 101.6)cm	21-5/8 (~55cm)	377 (~171.4kg)
Medium duty (10 gauge steel)					
H-25-MD	$\frac{1}{4}$ (~0.19 m ³)	4,000 (~1,818kg)	25 x 46 x 18 (63.5 x 116.8 x 45.7)	11-5/8 (~29.5cm)	229 (~104.1kg)
H-50-MD	$\frac{1}{2}$ (~0.38 m ³)	4,000 (~1,818kg)	25 x 51 $\frac{1}{4}$ x 28 (63.5 x 130.2 x 71.1)cm	11-5/8 (~29.5cm)	276 (~125.5kg)
H-100-MD	1 (~0.76 m ³)	4,000 (~1,818kg)	49 x 51 $\frac{1}{4}$ x 28 (124.5 x 130.2 x 71.1)cm	21-5/8 (~55cm)	395 (~179.5kg)
H-150-MD	1 $\frac{1}{2}$ (~1.15 m ³)	4,000 (~1,818kg)	49 x 52 x 40 (124.5 x 132.1 x 101.6)cm	21-5/8 (~55cm)	463 (~210.5kg)
Heavy duty (8 gauge steel)					
H-25-HD	$\frac{1}{4}$ (~0.19 m ³)	6,000 (~2,727kg)	25 x 46 x 18 (63.5 x 116.8 x 45.7)	11-5/8 (~29.5cm)	216 (~98.2kg)
H-50-HD	$\frac{1}{2}$ (~0.38 m ³)	6,000 (~2,727kg)	25 x 51 $\frac{1}{4}$ x 28 (63.5 x 130.2 x 71.1)cm	11-5/8 (~29.5cm)	279 (~126.8kg)
H-100-HD	1 (~0.76 m ³)	6,000 (~2,727kg)	49 x 51 $\frac{1}{4}$ x 28 (124.5 x 130.2 x 71.1)cm	21-5/8 (~55cm)	462 (~210kg)
H-150-HD	1 $\frac{1}{2}$ (~1.15 m ³)	6,000 (~2,727kg)	49 x 52 x 40 (124.5 x 132.1 x 101.6)cm	21-5/8 (~55cm)	540 (~245.5kg)
D-series Hoppers (self-dumping steel hoppers with bumper release)					
Light duty 2,000lb (909kg) maximum rated load models; fabricated from 12 gauge steel					
Model	Volume in Cubic Yards (~m ³)	Hopper Inside Dimensions in Inches (~cm)	Overall Dimensions (W x D x H) in Inches (~cm)	Distance between Fork Pocket Centers in Inches (~cm)	Net Weight in Pounds (~kg)
D-25-LD	$\frac{1}{4}$ (~0.19 m ³)	20 x 41 $\frac{1}{4}$ x 27 $\frac{1}{8}$ ~(50.8 x 104.8 x 70.8)cm	26 x 52 x 38 ~(66 x 132.1 x 96.5)cm	18 (~45.7cm)	360 (~163.6kg)
D-33-LD	$\frac{1}{3}$ (~0.25 m ³)	20 x 41 $\frac{1}{4}$ x 27 $\frac{1}{8}$ ~(50.8 x 104.8 x 70.8)cm	26 x 52 x 38 ~(66 x 132.1 x 96.5)cm	18 (~45.7cm)	375 (~170.5kg)
D-50-LD	$\frac{1}{2}$ (~0.38 m ³)	30 x 41 $\frac{1}{4}$ x 27 $\frac{1}{8}$ ~(76.2 x 104.8 x 70.8)cm	33 $\frac{1}{4}$ x 52 x 38 ~(84.5 x 132.1 x 96.5)cm	18 (~45.7cm)	410 (~186.4kg)
D-75-LD	$\frac{3}{4}$ (~0.57 m ³)	28 $\frac{1}{4}$ x 54 $\frac{1}{2}$ x 32 $\frac{1}{2}$ ~(71.8 x 138.4 x 82.6)cm	31 $\frac{1}{2}$ x 60 $\frac{1}{2}$ x 43 ~(80 x 153.7 x 109.2)cm	18 (~45.7cm)	480 (~218.2kg)
D-100-LD	1 (~0.76 m ³)	38 x 54 $\frac{1}{4}$ x 32 $\frac{1}{2}$ ~(96.5 x 138.4 x 82.6)cm	41 $\frac{1}{4}$ x 61 x 42 $\frac{3}{8}$ ~(104.8 x 154.9 x 108.3)cm	18 (~45.7cm)	524 (~238.2kg)
D-150-LD	1 $\frac{1}{2}$ (~1.15 m ³)	40 x 63 $\frac{3}{4}$ x 41 $\frac{1}{2}$ ~(71.8 x 138.4 x 82.6)cm	43 $\frac{3}{4}$ x 61 x 52 ~(109.9 x 154.9 x 132.1)cm	28 (~71.1cm)	630 (~286.4kg)
D-200-LD	2 (~1.53 m ³)	53 x 63 $\frac{3}{4}$ x 41 $\frac{1}{2}$ ~(134.6 x 162 x 105.4)cm	56 $\frac{1}{4}$ x 61 x 52 $\frac{3}{8}$ ~(142.9 x 154.9 x 133)cm	28 (~71.1cm)	725 (~329.5kg)
D-250-LD	2 $\frac{1}{2}$ (~1.91 m ³)	66 $\frac{1}{4}$ x 63 $\frac{3}{4}$ x 41 $\frac{1}{2}$ ~(168.3 x 162 x 105.4)cm	69 $\frac{1}{2}$ x 69 x 52 ~(176.5 x 175.3 x 132.1)cm	28 (~71.1cm)	760 (~345.5kg)
D-300-LD	3 (~2.29 m ³)	78 $\frac{3}{16}$ x 63 $\frac{3}{4}$ x 41 $\frac{1}{2}$ ~(198.6 x 162 x 105.4)cm	81 $\frac{7}{16}$ x 61 x 50 $\frac{3}{4}$ ~(206.9 x 154.9 x 128.9)cm	28 (~71.1cm)	975 (~443.2kg)

Model	Volume in Cubic Yards (m ³)	Uniform Maximum Rated Load in Pounds (kg)	Overall Dimensions (W x D x H) in Inches (cm)	Distance between Fork Pocket Centers in Inches (cm)	Net Weight in Pounds (kg)
Medium duty 4,000lb (1,818kg) maximum rated load models; fabricated from 10 gauge steel					
D-25-MD	$\frac{1}{4}$ (~0.19 m ³)	20 x 41 $\frac{1}{4}$ x 27 $\frac{7}{8}$ ~(50.8 x 104.8 x 70.8)cm	26 x 52 x 38 ~(66 x 132.1 x 96.5)cm	18 (~45.7cm)	385 (~175kg)
D-33-MD	$\frac{1}{3}$ (~0.25 m ³)	20 x 41 $\frac{1}{4}$ x 27 $\frac{7}{8}$ ~(50.8 x 104.8 x 70.8)cm	26 x 52 x 38 ~(66 x 132.1 x 96.5)cm	18 (~45.7cm)	390 (~177.3kg)
D-50-MD	$\frac{1}{2}$ (~0.38 m ³)	30 x 41 $\frac{1}{4}$ x 27 $\frac{7}{8}$ ~(76.2 x 104.8 x 70.8)cm	33 $\frac{3}{4}$ x 52 x 38 ~(84.5 x 132.1 x 96.5)cm	18 (~45.7cm)	420 (~190.9kg)
D-75-MD	$\frac{3}{4}$ (~0.57 m ³)	28 $\frac{1}{4}$ x 54 $\frac{1}{2}$ x 32 $\frac{1}{2}$ ~(71.8 x 138.4 x 82.6)cm	31 $\frac{1}{2}$ x 60 $\frac{1}{2}$ x 43 ~(80 x 153.7 x 109.2)cm	18 (~45.7cm)	525 (~238.6kg)
D-100-MD	1 (~0.76 m ³)	38 x 54 $\frac{1}{4}$ x 32 $\frac{1}{2}$ ~(96.5 x 138.4 x 82.6)cm	41 $\frac{1}{4}$ x 61 x 42 $\frac{5}{8}$ ~(104.8 x 154.9 x 108.3)cm	18 (~45.7cm)	625 (~284.1kg)
D-150-MD	1 $\frac{1}{2}$ (~1.15 m ³)	40 x 63 $\frac{3}{4}$ x 41 $\frac{1}{2}$ ~(71.8 x 138.4 x 82.6)cm	43 $\frac{3}{4}$ x 61 x 52 ~(109.9 x 154.9 x 132.1)cm	28 (~71.1cm)	670 (~304.5kg)
D-200-MD	2 (~1.53 m ³)	53 x 63 $\frac{3}{4}$ x 41 $\frac{1}{2}$ ~(134.6 x 162 x 105.4)cm	56 $\frac{1}{4}$ x 61 x 52 $\frac{3}{8}$ ~(142.9 x 154.9 x 133)cm	28 (~71.1cm)	730 (~331.8kg)
D-250-MD	2 $\frac{1}{2}$ (~1.91 m ³)	66 $\frac{1}{4}$ x 63 $\frac{3}{4}$ x 41 $\frac{1}{2}$ ~(168.3 x 162 x 105.4)cm	69 $\frac{1}{2}$ x 69 x 52 ~(176.5 x 175.3 x 132.1)cm	28 (~71.1cm)	795 (~361.4kg)
D-300-MD	3 (~2.29 m ³)	78 $\frac{3}{16}$ x 63 $\frac{3}{4}$ x 41 $\frac{1}{2}$ ~(198.6 x 162 x 105.4)cm	81 $\frac{7}{16}$ x 61 x 50 $\frac{3}{4}$ ~(206.9 x 154.9 x 128.9)cm	28 (~71.1cm)	991 (~450.5kg)
Heavy duty 6,000lb (2,727kg) maximum rated load models; fabricated from 8 gauge steel					
D-25-HD	$\frac{1}{4}$ (~0.19 m ³)	20 x 41 $\frac{1}{4}$ x 27 $\frac{7}{8}$ ~(50.8 x 104.8 x 70.8)cm	26 x 52 x 38 ~(66 x 132.1 x 96.5)cm	18 (~45.7cm)	410 (~186.4kg)
D-33-HD	$\frac{1}{3}$ (~0.25 m ³)	20 x 41 $\frac{1}{4}$ x 27 $\frac{7}{8}$ ~(50.8 x 104.8 x 70.8)cm	26 x 52 x 38 ~(66 x 132.1 x 96.5)cm	18 (~45.7cm)	420 (~190.9kg)
D-50-HD	$\frac{1}{2}$ (~0.38 m ³)	30 x 41 $\frac{1}{4}$ x 27 $\frac{7}{8}$ ~(76.2 x 104.8 x 70.8)cm	33 $\frac{3}{4}$ x 52 x 38 ~(84.5 x 132.1 x 96.5)cm	18 (~45.7cm)	455 (~206.8kg)
D-75-HD	$\frac{3}{4}$ (~0.57 m ³)	28 $\frac{1}{4}$ x 54 $\frac{1}{2}$ x 32 $\frac{1}{2}$ ~(71.8 x 138.4 x 82.6)cm	31 $\frac{1}{2}$ x 60 $\frac{1}{2}$ x 43 ~(80 x 153.7 x 109.2)cm	18 (~45.7cm)	560 (~254.5kg)
D-100-HD	1 (~0.76 m ³)	38 x 54 $\frac{1}{4}$ x 32 $\frac{1}{2}$ ~(96.5 x 138.4 x 82.6)cm	41 $\frac{1}{4}$ x 61 x 42 $\frac{5}{8}$ ~(104.8 x 154.9 x 108.3)cm	18 (~45.7cm)	620 (~281.8kg)
D-150-HD	1 $\frac{1}{2}$ (~1.15 m ³)	40 x 63 $\frac{3}{4}$ x 41 $\frac{1}{2}$ ~(71.8 x 138.4 x 82.6)cm	43 $\frac{3}{4}$ x 61 x 52 ~(109.9 x 154.9 x 132.1)cm	28 (~71.1cm)	745 (~338.6kg)
D-200-HD	2 (~1.53 m ³)	53 x 63 $\frac{3}{4}$ x 41 $\frac{1}{2}$ ~(134.6 x 162 x 105.4)cm	56 $\frac{1}{4}$ x 61 x 52 $\frac{3}{8}$ ~(142.9 x 154.9 x 133)cm	28 (~71.1cm)	778 (~353.6kg)
D-250-HD	2 $\frac{1}{2}$ (~1.91 m ³)	66 $\frac{1}{4}$ x 63 $\frac{3}{4}$ x 41 $\frac{1}{2}$ ~(168.3 x 162 x 105.4)cm	69 $\frac{1}{2}$ x 69 x 52 ~(176.5 x 175.3 x 132.1)cm	28 (~71.1cm)	890 (~404.5kg)
D-300-HD	3 (~2.29 m ³)	78 $\frac{3}{16}$ x 63 $\frac{3}{4}$ x 41 $\frac{1}{2}$ ~(198.6 x 162 x 105.4)cm	81 $\frac{7}{16}$ x 61 x 50 $\frac{3}{4}$ ~(206.9 x 154.9 x 128.9)cm	28 (~71.1cm)	991 (~450.5kg)
D-350-HD	3 $\frac{1}{2}$ (~2.68 m ³)	88 $\frac{1}{4}$ x 63 $\frac{3}{4}$ x 41 $\frac{1}{2}$ ~(224.2 x 162 x 105.4)cm	92 x 69 x 52 ~(233.7 x 175.3 x 132.1)cm	28 (~71.1cm)	1,110 (~504.5kg)
Options					
Model	Description				Net Weight
H-DAMP-4	Hopper dumping speed regulator for 4,000lb (medium duty) models				30 lb. (13.6kg)
H-DAMP-6	Hopper dumping speed regulator for 6,000lb (heavy duty) models				40 lb. (18.2kg)
LEKP	"Leak proof" welded hopper				5 lb. (2.3kg)
D-DPLG-1	1in. drain plug option				2 lb. (0.9kg)
D-DPLG-2	2in. drain plug option				2 lb. (0.9kg)
H-DPLG-1	1in. drain plug option				2 lb. (0.9kg)
H-DPLG-2	2in. drain plug option				2 lb. (0.9kg)
LUG	4 welded lifting lugs (around perimeter of hopper mouth)				150 lb. (68.2kg)

Heavy-duty polyethylene lids

Model	Number of Pieces	Part Number	Fits Hopper Models	Net Weight in Pounds (kg)
PLID-H-25	1	37-024-038-004	H-25-LD, H-25-MD, H-25-HD	7 (3.2kg)
PLID-H-50	1	37-024-038-003	H-50-LD, H-50-MD, H-50-HD	8 (3.6kg)
PLID-H-100	2	37-024-038-002	H-100-LD, H-100-MD, H-100-HD	14 (6.4kg)
PLID-H-150	2	37-024-038-001	H-150-LD, H-150-MD, H-150-HD	16 (7.3kg)
PLID-D-33	1	37-024-087-002	D-33-LD, D-33-MD, D-33-HD	7 (3.2kg)
PLID-D-50	1	37-024-087-001	D-50-LD, D-50-MD, D-50-HD	8 (3.6kg)
PLID-D-75	1	37-024-086-002	D-75-LD, D-75-MD, D-75-HD	9 (4.1kg)
PLID-D-100	1	37-024-086-001	D-100-LD, D-100-MD, D-100-HD	10 (4.5kg)
PLID-D-150	1	37-024-085-004	D-150-LD, D-150-MD, D-150-HD	14 (6.4kg)
PLID-D-200	2	37-024-085-003	D-200-LD, D-200-MD, D-200-HD	16 (7.3kg)
PLID-D-250	2	37-024-085-002	D-250-LD, D-250-MD, D-250-HD	18 (8.2kg)
PLID-D-300	2	37-024-085-001	D-300-LD, D-300-MD, D-300-HD	20 (9.1kg)

Caster kits

Model	Dimensions in Inches (cm)	Uniform Capacity in Pounds (kg)	Caster Material	Quantity per Order	Net Weight in Pounds (kg)
HOP-SC6-2	6 x 2 (15¼ x 5.1)cm	4,800 (2,182kg)	Semi-steel	4	33 (15kg)
HOP-SC8-2	8 x 2 (20.3 x 5.1)cm	4,800 (2,182kg)	Semi-steel	4	42 (19.1kg)
HOP-RC6-2	6 x 2 (15¼ x 5.1)cm	2,400 (1,091kg)	Mold-on rubber	4	28 (12.7kg)
HOP-RC8-2	8 x 2 (20.3 x 5.1)cm	2,400 (1,091kg)	Mold-on rubber	4	37 (16.8kg)
HOP-PC6-2	6 x 2 (15¼ x 5.1)cm	4,800 (2,182kg)	Polyurethane on steel	4	33 (15kg)
HOP-PC8-2	8 x 2 (20.3 x 5.1)cm	4,800 (2,182kg)	Polyurethane on steel	4	42 (19.1kg)
HOP-PHC6-2	6 x 2 (15¼ x 5.1)cm	4,800 (2,182kg)	Glass-filled nylon	4	37 (16.8kg)
HOP-PHC8-2	8 x 2 (20.3 x 5.1)cm	4,800 (2,182kg)	Glass-filled nylon	4	54 (24.5kg)
HOP-SC6-2.5	6 x 2½ (15¼ x 6.4)cm	6,000 (2,727kg)	Steel	4	65 (29.5kg)

NOTE: "Uniform capacity" is the maximum weight that each caster set can support, and equals the combined weight of the hopper and its contents. **ONLY select a caster kit that equals or exceeds the maximum rated load of your hopper!**

Fig. 1: H-series hoppers diagram and parts list

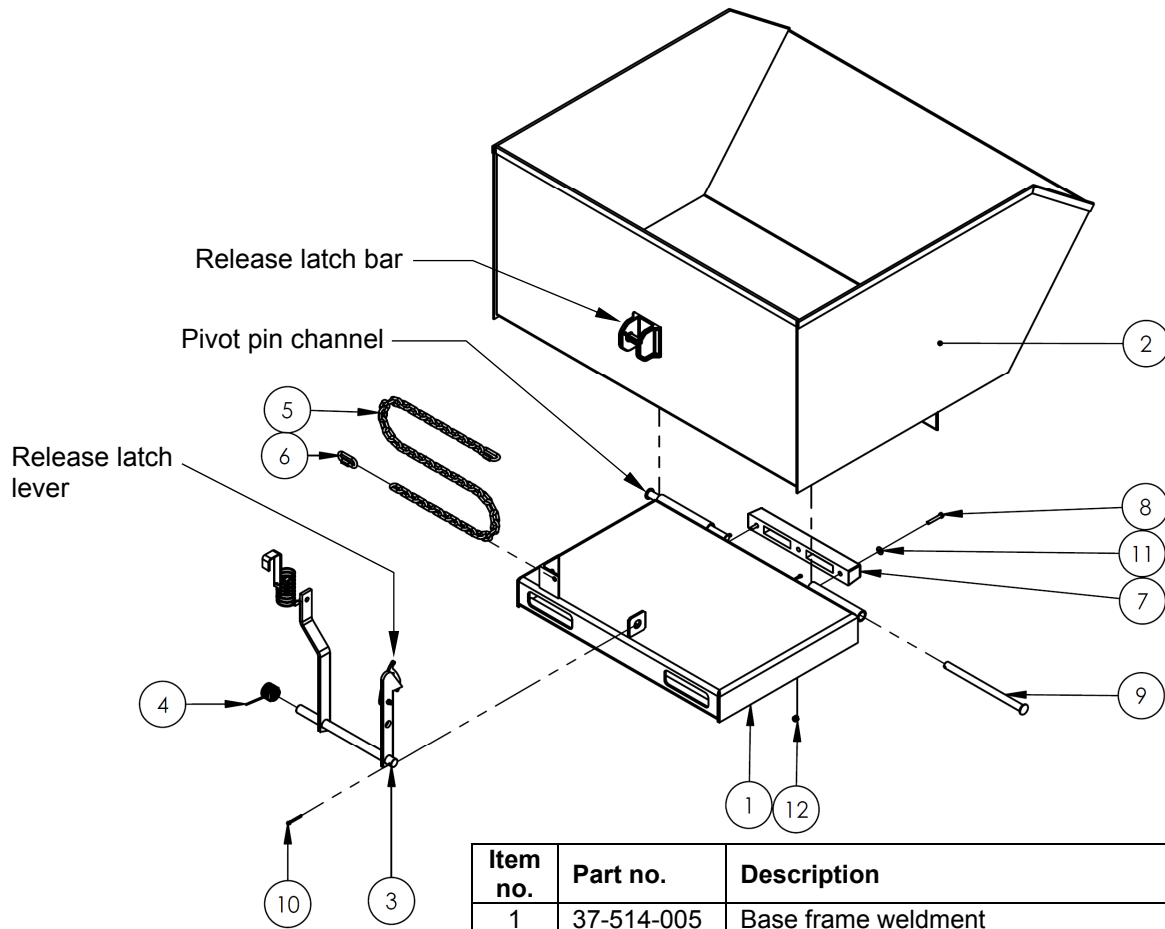

Item no.	Part no.	Description	Quantity
1	37-514-005	Base frame weldment	1
2	37-545-008	Hopper chute weldment	1
3	37-537-010	Chute release lever weldment	1
4	37-146-005	Release torsion spring	1
5	99-145-037	⁵ / ₁₆ in. x 36in. safety chain	1
6	99-145-053	⁵ / ₁₆ in. quick link	2
7	29-048-061	Rubber pumper	1
8	11061	⁵ / ₁₆ in. – 18 x 2in. HHCS zinc-plated bolt	2
9	37-112-045	Pivot pin	2
10	65127	³ / ₁₆ in. x 2in. zinc-plated cotter pin	3
11	33006	⁵ / ₁₆ in. USS zinc-plated flat washer	2
12	37021	⁵ / ₁₆ in. – 18 nylock nut	2

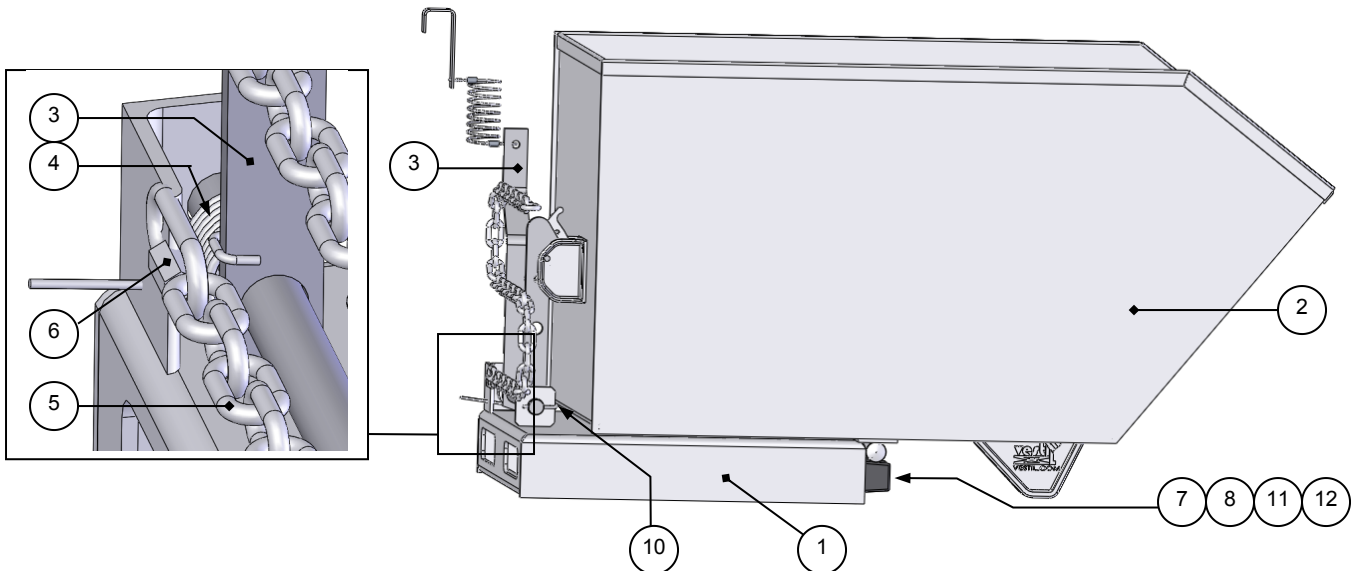
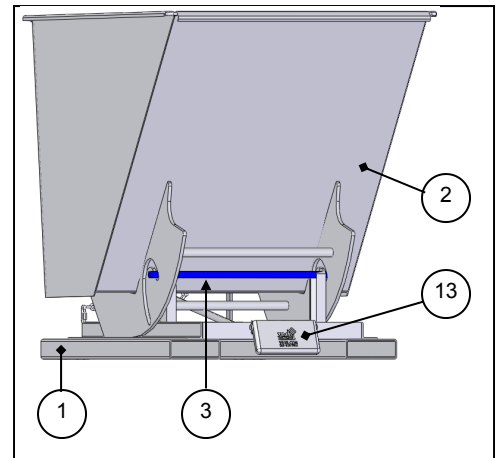
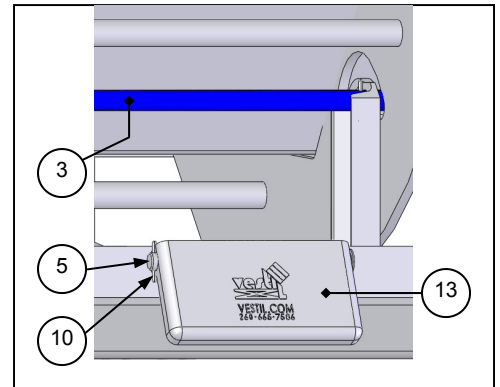
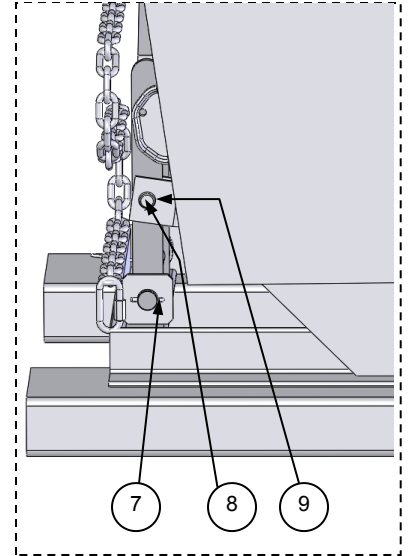
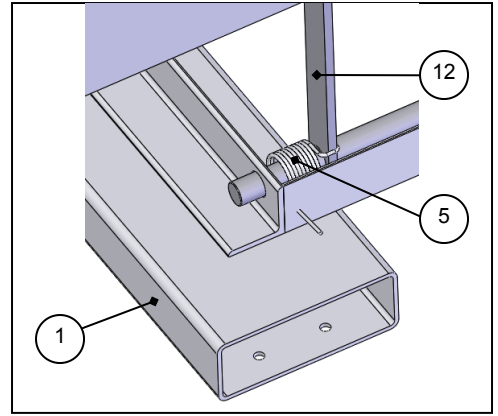
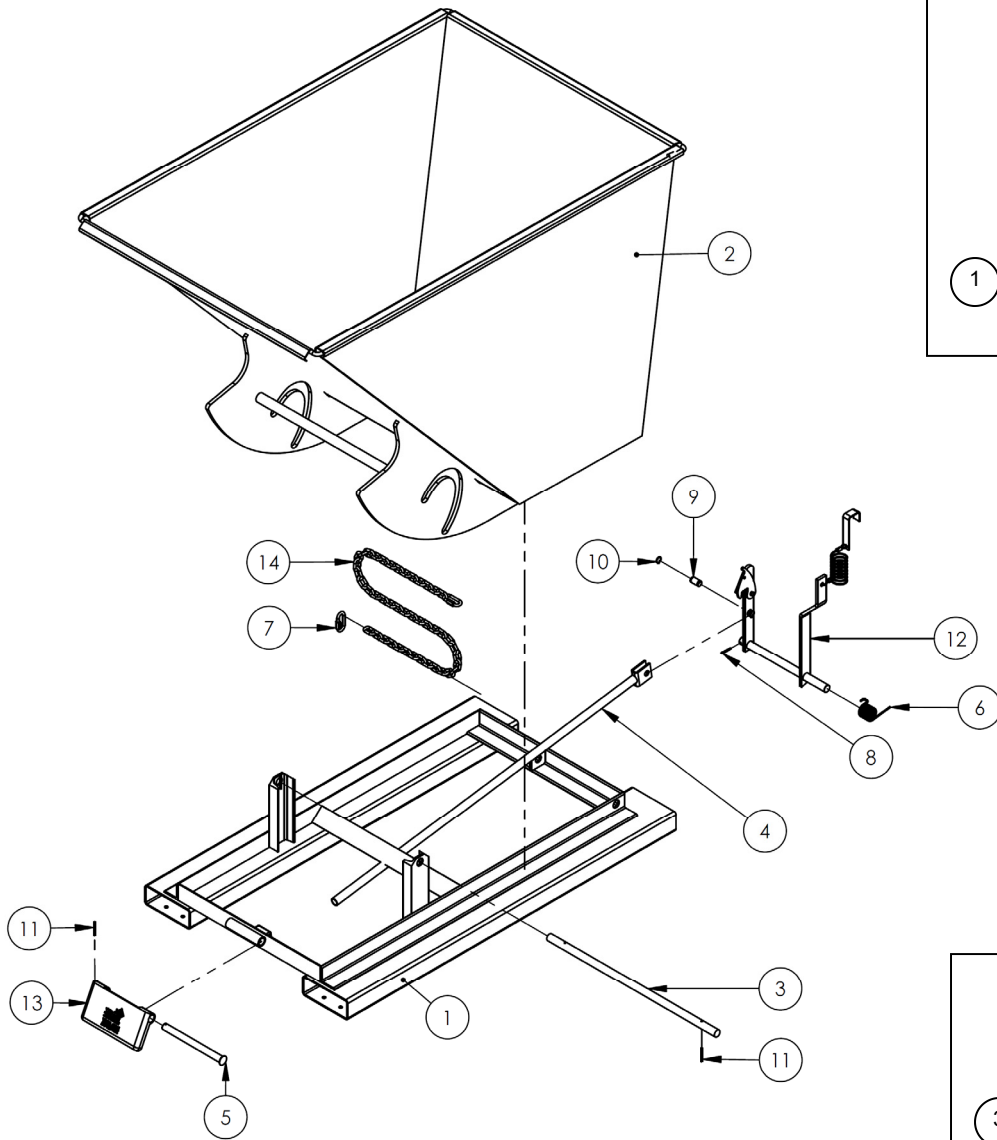
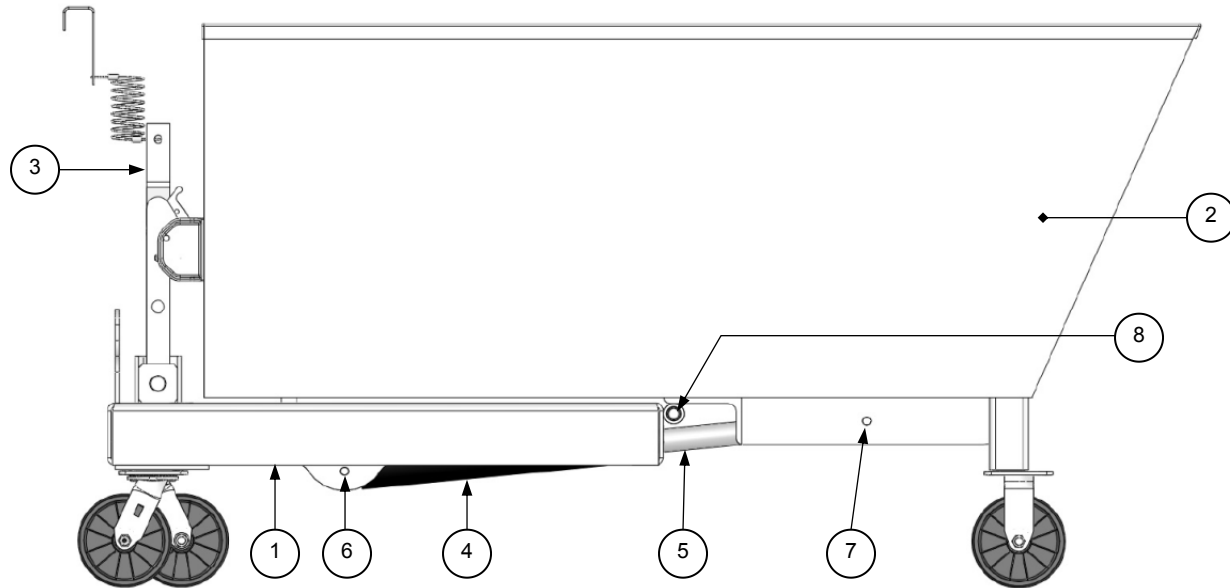

Fig. 2: D-series hoppers diagram and parts list



Item No.	Part No.	Description	Quantity
1	37-514-004	Base frame weldment	1
2	37-545-046	Chute weldment	1
3	37-112-007	Pivot pin	1
4	37-537-006	Release lever rod weldment	1
5	37-112-006	Bumper plate pin	1
6	37-146-005	Chute release torsion spring	2
7	99-145-053	⁵ / ₁₆ in. quick link	1
8	65125	³ / ₁₆ in. x 1 1/2 in. zinc-plated cotter pin	1
9	01-112-009	Hinge pin	2
10	68015	³ / ₄ in. external retaining ring	3
11	64141	³ / ₁₆ in. x 2 in. spring pin	1
12	37-537-010	Chute release assembly	1
13	37-037-040	Chute release bumper plate	1
14	99-145-037	⁵ / ₁₆ in. x 36in. safety chain	1

FIG. 3: Leak Proof H-Hopper (Option LEKP) Diagram and Parts List

Item no.	Part no.	Description	Quantity
1	S929134-F1	Leak proof base frame weldment	1
2	S929134-C1A	Leak proof chute weldment	1
3	37-537-012	Release lock lever assembly	1
4	S929134-CYL1-B	1 in. x 14 in. hydraulic cylinder body	1
5	S929134-CYL1-R	1 in. x 14 in. hydraulic cylinder rod	1
6	S929134-P4B	Cylinder pin (body end)	1
7	S929134-P4A	Cylinder pin (rod end)	1
8	37-112-003	Hinge axle pin hoppers (H style)	1

NOTICE DO NOT put or store corrosive substances in the chute of a hopper. Corrosion will damage the chute and cause it to no longer be watertight. Similarly, do not allow water to accumulate in the chute, which will allow rust to develop. Rinse the hopper chute after emptying contents, and dry the chute before filling it again.

To dump a leak-proof H-hopper, simply pull the release lever. Once released, the cylinder will extend until the chute dumps. Manually return the chute to the latched position.

SIGNAL WORDS:

Vestil Manufacturing Corp. created this manual to acquaint owners and users of our fork-mounted hoppers with safe use and maintenance procedures. Although Vestil diligently strives to identify foreseeable, hazardous situations, this manual cannot address every conceivable danger. The end-user is ultimately responsible for exercising sound judgment at all times.

The mechanisms of each hopper are relatively intuitive to operate. Nonetheless, all persons who might use or operate this product should familiarize themselves with the instructions provided in this manual. Each person who **might** use or maintain the product must read this entire manual and fully understand the directions BEFORE using or performing maintenance on the hopper.

Failure to apply the directions in this manual might lead to serious personal injury or even death. Vestil is **not liable** for any injury or property damage that occurs as a consequence of failing to apply either: 1) the instructions that appear in this manual; or 2) the information disclosed on labels affixed to the product. Furthermore, failure to exercise good judgment and common sense could result in property damage, serious personal injury or death, and also are **not the responsibility of Vestil**.

To draw attention to hazards that users might encounter, this manual classifies personal injury risks and situations that could lead to property damage with SIGNAL WORDS. These signal words announce an associated safety message. The reader must understand that the signal word chosen indicates the seriousness of the described hazard.



Identifies a hazardous situation which, if not avoided, WILL result in DEATH or SERIOUS INJURY. Use of this signal word is limited to the most extreme situations.



Identifies a hazardous situation which, if not avoided, COULD result in DEATH or SERIOUS INJURY.



Indicates a hazardous situation which, if not avoided, COULD result in MINOR or MODERATE injury.



Identifies practices likely to result in product/property damage, such as operation that might damage the hopper.

Safety Recommendations:

Study the entire manual before using the product for the first time. Read the manual when necessary to refresh your understanding of the safe operation, inspection and maintenance procedures explained on p.9. If questions remain after you finish reading this manual, ask your supervisor or employer for assistance. **DO NOT** attempt to resolve any problems with the boom unless you are authorized to do so and are *certain* that it will be safe to use afterwards.



Electrocution might result if the hopper contacts electrified wires. Reduce the likelihood that an operator or bystander might be electrocuted by applying **common sense:**

- **DO NOT** *contact* electrified wires with the hopper or any part of the forklift truck.
- **DO NOT** use the hopper in an area where it *will* contact electrified wires.
- Before using the hopper, always inspect the usage area for unusual conditions that require special precautions.



Material handling is dangerous. Improper or careless operation might result in serious personal injuries. Reduce the likelihood of injury boom operators by applying the following:

- **Failure to read & understand the instructions included in this manual before using or servicing the hopper is a misuse.**
- **DO NOT** use a malfunctioning or structurally damaged hopper. Examples structural damage include: 1) damage to the hopper release mechanism (that allows the hopper to dump); 2) broken fork pocket(s); 3) main connection pin; or 4) broken welds. Inspect the hopper before each use according to the inspection instructions on p. 9. **DO NOT** use the hopper unless it passes every part of the inspection.
- **DO NOT** use the hopper if the safety chain is damaged or absent; **DO NOT** lift the hopper until it is securely connected to the carriage of the fork truck with the safety chain.
- **DO NOT** fill the hopper with a load weighing more than the maximum rated load (see Table, p. 2-3).
- **DO NOT** stand beneath or travel under the hopper at any time. **DO NOT** permit any person to stand beneath or travel under the hopper.
- **Hoppers with lifting lugs** can be lifted with overhead hoists and cranes. **DO NOT** lift a hopper unless the chute is securely latched to the frame. The hopper must not be able to rotate while it is suspended.
- **DO NOT** allow people to ride on or in the hopper.
- **DO NOT** use the hopper if any product label (see p. 10 or 11) is unreadable, damaged, or missing. Contact Vestil to order replacement labels.
- **ALWAYS** apply proper (fork) lift truck operation practices learned during your training program. Before raising the hopper from the floor **AND** tilt the (forklift) mast toward the cab of the truck to ensure that the hopper will not slide towards the tips of the forks.
- **DO NOT** modify the hopper in any way! Modification(s) might make the hopper unsafe to use.
- **DO NOT** dump the hopper **UNLESS** every person in the vicinity is safely behind the forklift truck.
- **DO NOT** dump the hopper if the forklift is facing down a slope. Only dump the hopper while parked on a level surface.

Loading instructions:

Verify that the hopper chute is latched to the base frame, i.e. NOT released and cannot rotate, before filling the chute with refuse. Warning: Do not exceed the dumper's (and if portable, its casters') load ratings or fill the hopper above the top of the hopper's sides. Injury to personnel or permanent damage to the equipment could result from overloading.

Standard D-series and H-series self-dumping hoppers are suitable for use indoors and outdoors and in most industrial and commercial settings. They are intended for use in conjunction with a rider forklift truck as a means to dump non-hazardous refuse into larger trash receptacles.

D-series hoppers: the chute rotates through a 70° dump angle. To dump the hopper, the forklift operator can either

1. Press the bumper release plate (Item no. 13 on p. 6) on the front of the hopper by driving the forklift forward until the side of the dumpster presses against the bumper plate and releases the chute; or
2. Manually release the chute from the forklift cab by pulling the release cable.

H-series hoppers: the low-profile hopper rotates through a 90° dump angle. To dump the hopper, the forklift operator must simply pull the release cable.

Use instructions:

Step 1: Drive the forklift forward to insert the forks into the fork pockets. Continue driving forward until the forks are completely inserted.

- D-series: drive as far forward as possible;
- H-series: drive forward until the forks contact the caps at the ends of the fork pockets.

Step 2: Securely attach the hopper to the fork carriage with the safety chain (item no. 5 on p. 5; item no. 14 on p. 6). Wrap the chain around part of the fork carriage; then connect the quick link at the end of the chain to a link in the chain with as little slack as possible.

WARNING DO NOT wrap the release cable around any part of your body, especially your hand(s), or attach the handle at the end of the cable to your clothing. If you do and the chute is released, you might be seriously injured.

Step 3: Store the handle of the release cable within reach of the forklift operator, for instance, by hooking it to the frame of the cab. Make sure that there is plenty of slack in the cable to avoid accidentally releasing/dumping the chute.

Step 4: Drive the forklift to the trash receptacle; then tilt the mast of the forklift forward and raise the forks. Elevate the hopper to a height as shown in the diagrams below:

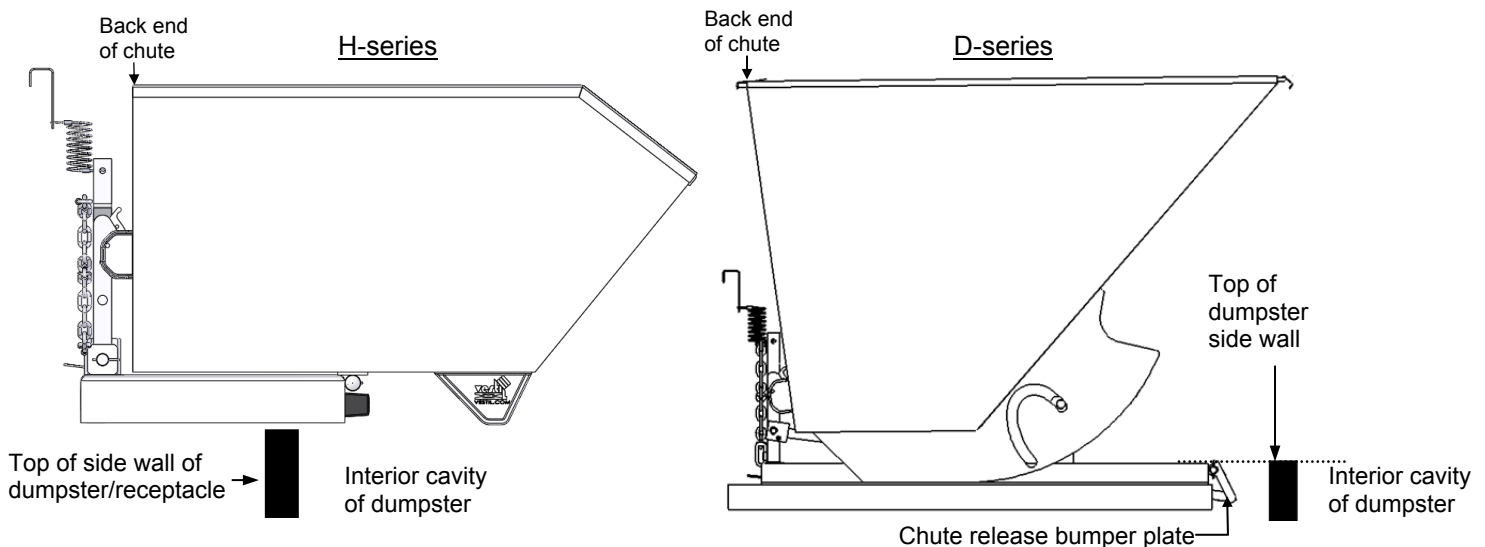

Step 5: Dump the contents of the hopper by releasing the chute. To release the chute, pull the release cable. For D-series hoppers, an alternative method of releasing the chute is to drive the forklift toward the dumpster and contact the chute release bumper plate (item no. 13 on p. 6) with the top of the side wall of the dumpster.

Step 6: Return the chute to the latched position. Tilt the forklift mast toward the cab; then back away from the dumpster. D-series hoppers automatically return to the latched position. For H-series hoppers, lower the forks until the hopper contacts the ground; then slowly lower the forks the rest of the way to the ground until the chute latches to the base frame. Confirm that the chute is properly latched by raising the forks. The chute should not rotate. If necessary, lower the forks completely and manually latch the chute to the frame by pressing down on the back of the chute (see "H-series" diagram in Step 4).

Inspections & Maintenance:

⚠WARNING If one or more problem is discovered during an inspection, restore the hopper to normal operating condition BEFORE using it again. DO NOT use a structurally damaged hopper. Structural damage includes, but is not limited to, cracked welds, warping or deformation of one or both of the fork pockets, chute, pivot points, or frame members.

Inspections:

(A) Before each use inspect the following components:

- 1.) Release cable – fraying, birdcaging, thinning;
- 2.) Hopper chute or base frame – damage, deformation, corroded or excessively rusted regions;
- 3.) Pivot points – unusual noise or binding (when chute rotates), distortion of pivot pin or pivot pin channels (see Figures 1 and 2 on p. 5 & 6);
- 4.) Release/Latch mechanisms – torsion spring should cause the chute release lever weldment (item number 3 on p. 5; item no. 3 on p. 6) to automatically recoil; the release latch should firmly engage the release lock bar proper function;
- 5.) Hopper retaining mechanisms – look for evidence of fatigue or damage to the safety chain, the point of attachment to the base frame, or the quick links.

(B) Inspect the following components at least once per month and replace any component that is excessively worn or no longer operates normally:

- 1.) Pivot points – look for excessive wear, warping, or other significant damage to pivot pins, cotter pins that retain pivot pins in place, or pin channels (see Figures 1 and 2 on p. 5 & 6).
- 2.) Fasteners (bolts, nuts, pins, cotter pins, retaining rings) – inspect for looseness and wear.
- 3.) Casters – check for looseness, excessive wear, or damage to the casters, caster bearings, mounting brackets, or hardware.
- 4.) Release mechanism – verify that the mechanisms function properly. The torsion spring should cause the chute release lever weldment (item number 3 on p. 5 & 6) to automatically recoil; the release latch should firmly engage the release lock bar proper function;
- 5.) All moving parts – listen for unusual noises and watch for irregular movement. Remove dirt and debris from areas that could affect the hopper's dumping motion;
- 6.) Labels – all labels must be firmly affixed in the locations shown in Fig. 3 or 4 on p. 10 or 11.

Maintenance:

Implement a maintenance program to ensure that the product functions properly and is adequately maintained. The following steps should be applied to complement established maintenance programs.

Step 1: Tag the hopper, "Out of Service."

Step 2: Remove any dirt or other matter from all surfaces.

Step 3: Conduct a "Before each use" inspection. If deformity, corrosion, rusting, or excessive wear of structural members is found, DO NOT use the product.

Step 4: Perform all other necessary adjustments, replacements and/or repairs, but DO NOT modify the hopper.

⚠WARNING The reader should understand the significant difference between necessary adjustments and repairs, and modifications.

An "adjustment" is a simple correction that restores the hopper to normal operating condition, such as tightening loose fasteners, or removing dirt or other debris from the surface. "Repair" means removing worn parts and installing new replacement parts.

➤ DO NOT use the hopper if adjustments and/or repairs are incomplete! Return it to service ONLY after finishing all necessary repairs and adjustments.

A "modification" is a change that alters the hopper from normal operating condition, like bending the structural members or removing a part or several parts. NEVER modify the hopper unless you are *certain* that the hopper will be safe to use afterwards, or without first obtaining express, written approval from Vestil. Modifications automatically void the Limited Warranty and might make the hopper unsafe to use.

Step 5: Make a dated record of any repairs, adjustments and/or replacements.

Fig. 3: H-series markings & label placement diagram

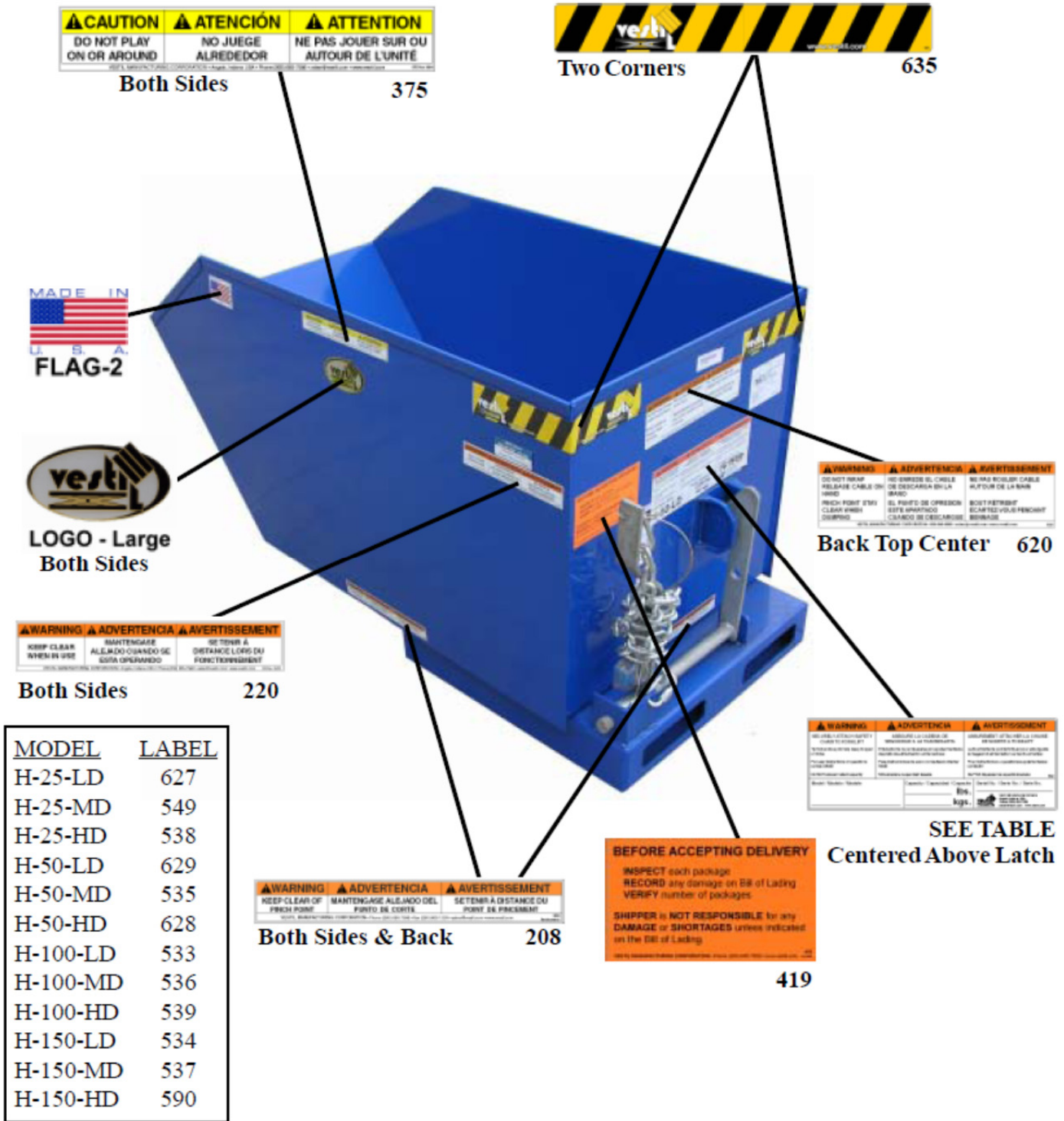
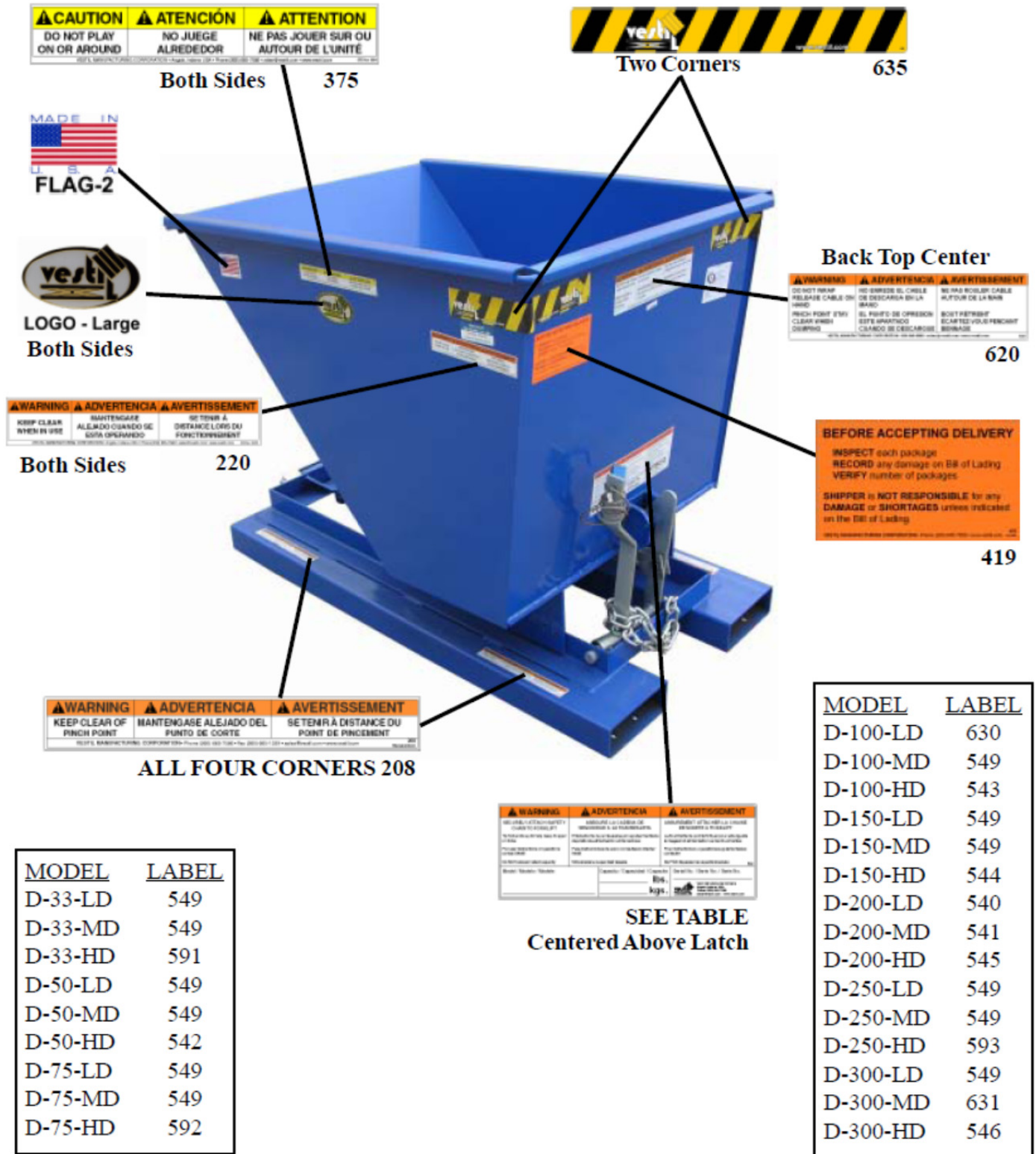

Fig. 4: D-series markings & label placement diagram



LIMITED WARRANTY

Vestil Manufacturing Corporation (“Vestil”) warrants this product to be free of defects in material and workmanship during the warranty period. Our warranty obligation is to provide a replacement for a defective original part if the part is covered by the warranty, after we receive a proper request from the warrantee (you) for warranty service.

Who may request service?

Only a warrantee may request service. *You are a warrantee if* you purchased the product from Vestil or from an authorized distributor AND Vestil has been fully paid.

What is an “original part”?

An original part is a part used to make the product as shipped to the warrantee.

What is a “proper request”?

A request for warranty service is proper if Vestil receives: 1) a photocopy of the Customer Invoice that displays the shipping date; AND 2) a written request for warranty service including your name and phone number. Send requests by any of the following methods:

<u>Mail</u>	<u>Fax</u>	<u>Email</u>
Vestil Manufacturing Corporation 2999 North Wayne Street, PO Box 507 Angola, IN 46703	(260) 665-1339 <u>Phone</u> (260) 665-7586	sales@vestil.com

In the written request, list the parts believed to be defective and include the address where replacements should be delivered.

What is covered under the warranty?

After Vestil receives your request for warranty service, an authorized representative will contact you to determine whether your claim is covered by the warranty. Before providing warranty service, Vestil may require you to send the entire product, or just the defective part or parts, to its facility in Angola, IN. The warranty covers defects in the following *original* dynamic components: motors, hydraulic pumps, electronic controllers, switches and cylinders. It also covers defects in *original* parts that wear under normal usage conditions (“wearing parts”): bearings, hoses, wheels, seals, brushes, batteries, and the battery charger.

How long is the warranty period?

The warranty period for original dynamic components is 1 year. For wearing parts, the warranty period is 90 days. Both warranty periods begin on the date when Vestil ships the product to the warrantee. If the product was purchased from an authorized distributor, the periods began when the distributor shipped the product. Vestil may extend the warranty period for products shipped from authorized distributors by *up to* 30 days to account for shipping time.

If a defective part is covered by the warranty, what will Vestil do to correct the problem?

Vestil will provide an appropriate replacement for any *covered* part. An authorized representative of Vestil will contact you to discuss your claim.

What is not covered by the warranty?

1. Labor;
2. Freight;
3. Occurrence of any of the following, which automatically voids the warranty:
 - Product misuse;
 - Negligent operation or repair;
 - Corrosion or use in corrosive conditions;
 - Inadequate or improper maintenance;
 - Damage sustained during shipping;
 - Accidents involving the product;
 - Unauthorized modifications: DO NOT modify the product IN ANY WAY without first receiving written authorization from Vestil. Modification(s) might make the product unsafe to use or might cause excessive and/or abnormal wear.

Do any other warranties apply to the product?

Vestil Manufacturing Corp. makes no other express warranties. All implied warranties are disclaimed to the extent allowed by law. Any implied warranty not disclaimed is limited in scope to the terms of this Limited Warranty.

