

Bullard AirGladiator Filters can be used in conjunction with other compressor safeguards to supply cleaner air to airline respirators. They can also be used to supply drier, cleaner air to pneumatic tools and systems. The Bullard AirGladiator can be used to remove water, oil, odors and organic vapors so that cleaner air is delivered to workers or equipment.

**Bullard airline filters will NOT remove carbon monoxide and other toxic gases from the airline.**

## Set-Up

### 1. Location:

Select a flat, stable location to mount the filter. Bolt the filter in position using the mounting base. For wall mount applications, the filter carrying handle is designed for mounting the unit to a wall.

### 2. Connection:

Connect compressor hose to the air inlet. Connect the respirator or pneumatic tool airline hose to the filter outlet. Tighten the connections to prevent leaks and possible pressure loss.

### 3. Assembly

Install the regulator inlet assembly by screwing the 1" male nipple on the end of the assembly into the 1" female inlet port on the filter body. Use Teflon<sup>®</sup> tape or thread sealant on the male threads before installing. Tighten with a wrench.

#### ▲ WARNING

When using a respirator, do not connect the filter to any air source unless you are certain it supplies breathable air. Failure to ensure breathable air source could result in death or serious injury.

## Operation

### 1. Air Requirements

#### a. Air Source Monitoring:

Federal Law requires use of carbon monoxide and/or high temperature monitors or alarms when oil lubricated compressors are used as sources of breathing air. If only a high temperature alarm is used, you must frequently test the compressor air for carbon monoxide to ensure it meets the Grade D requirements discussed below.

The law also requires that breathing air hose couplings be incompatible with outlets for other gas systems in order to prevent accidental connection of a supplied air respirator to non-respirable gases.

### b. Quality of Breathing Air:

Supplied breathing air entering and passing through this filter to a respirator must meet at least the requirements for Type 1 gaseous air as described in the Compressed Gas Association Commodity Specification G7.1 (Grade D or higher), as specified by federal law 42 CFR, Part 84, Subpart J, 84.141(b). The Bullard airline filter does not remove carbon monoxide and other toxic gases from the air being supplied. The requirements for Grade D breathable air include:

- Oxygen 19.5 - 23.0%
- Hydrocarbons (condensed) 5 mg/m<sup>3</sup> max.
- Carbon Monoxide 10 ppm max.
- Carbon Dioxide 1000 ppm max.
- No toxic contaminants at levels which would make the air unsafe to breathe.

Refer to the C.G.A. Commodity Specifications G7.1 for complete details. It is available from: Compressed Gas Association, 1235 Jefferson Davis Highway, Arlington, VA 22202.

### c. Air Pressure:

The air pressure at the filter inlet is a recommended maximum pressure of 100 psig (6.9 bar). Air will be released by the pressure relief valve when pressure within the filter exceeds 125 psig (8.6 bar). Air discharging from the filter can be controlled to meet specific air pressure requirements by using the pressure regulator adjustment knob. Refer to your respirator or pneumatic tool instruction manual to find the appropriate air pressures required for correct use of the equipment.

### d. Temperature:

Air supplied to the filter should not exceed 140° F (60° C). Therefore, do not connect the filter directly to the compressor exhaust manifold.

## 2. Correct Operation Procedures

**a. Drain** accumulated water and oil from the filter tank as required by opening the petcock drain valve. Normally the tank will need to be drained at least once a day. In humid climates, or if large amounts of water and oil are present in the air supply, drain the filter tank more often.

**b. Tighten** the fasteners which secure the head to the filter tank. Over time, the fasteners may loosen which could cause a leak in the air system. (Recommended torque is 20 lbf-ft).

Refer to **Figure 2** on page 2 of these instructions for set-up and operation.

#### ▲ WARNING

The AirGladiator filters do not remove carbon monoxide and other toxic gases. Review and observe all pertinent federal and state safety regulations in conjunction with airline respirators. Failure to observe safety regulations or improper use of Bullard Airline Filters could result in death or serious injury.

Distributed By:



2717 Tobey • Indianapolis, IN 46219  
(317) 545-0665 • FAX (317) 545-0670 • (800) 800-0665  
www.idsblast.com

## Cartridge Replacement

### ▲ WARNING

Use only Bullard 41AF cartridges as replacements. Bullard AirGladiator Filters are designed to use only Bullard filter cartridges. Failure to use the correct filter cartridge could result in death or serious injury.

The frequency of filter cartridge replacement depends on the conditions of the particular air system in which the filter is installed. However, the filter cartridge should be replaced immediately if:

- a. The user smells or tastes contaminants in the air being supplied to an air-supplied respirator, or;
- b. There is a large pressure drop in the system, even though the compressor and other components appear to be operating correctly.
- c. The filter has been in use for approximately one (1) year.

### Corrective Action

1. Shut off air supply and drain filter. Disconnect the filter from the air source before servicing.
2. Replace the Cartridge:
  - a. Separate the filter head from the cylinder housing by removing the bolts and lock washers from the top flanges.
  - b. After removing the 41AF filter cartridge, clean the inside of the tank to remove any remaining contaminants.
  - c. Insert a new Bullard 41AF filter cartridge. Tighten the fasteners across from each other and not in a circular sequence. This will help prevent warping of the filter head (Recommended tightness = 20 lbf-ft).
3. Record the date the filter was replaced on the label attached to the airline filter tank. You can develop a filter cartridge replacement schedule by monitoring the frequency with which the cartridge needs to be changed.
4. Reconnect the filter to the air source before use.
5. If conditions are not improved, do not use the filter until appropriate corrective measures have been taken.

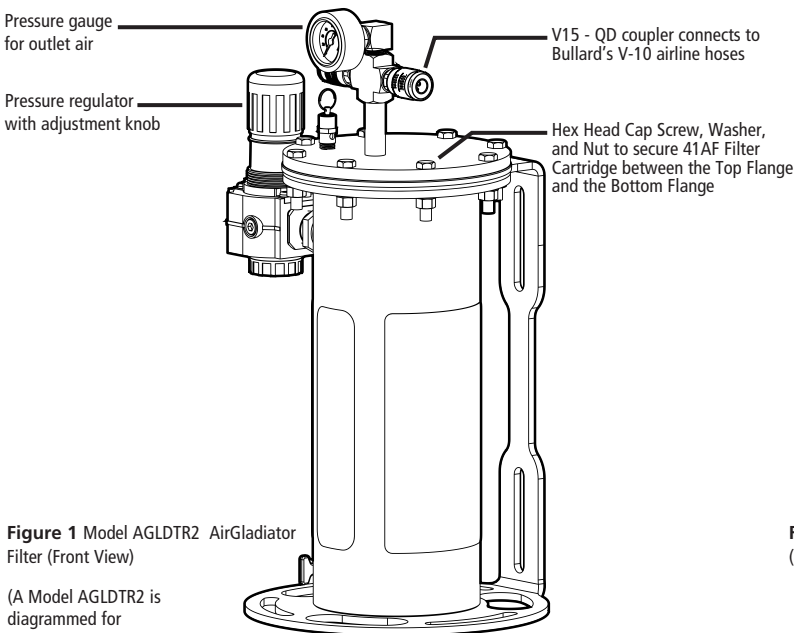

**Figure 1** Model AGLDTR2 AirGladiator Filter (Front View)

(A Model AGLDTR2 is diagrammed for illustration purposes.)

### Replaceable Filter Cartridge 7-Stage Operation

Cartridges effectively trap and remove impurities with little pressure loss. The supplied-air enters the filter at inlet connector travels through 6 layers of filter material and exits at outlet connector. Filter materials work in sequence to trap and hold water, oil, odors, and organic vapors so that cleaner air is delivered to workers or equipment.

### ▲ WARNING

Filter cartridge must be changed periodically for maximum efficiency. Frequency of cartridge changes depends on operating conditions. Cartridge should be changed immediately if respirator wearer feels, smells or tastes contaminants inside the respirator. Filter tank should be drained at least daily to remove trapped water and oil (a petcock is provided on the bottom of the tank for this purpose). Failure to follow these instructions could result in death or serious injury.

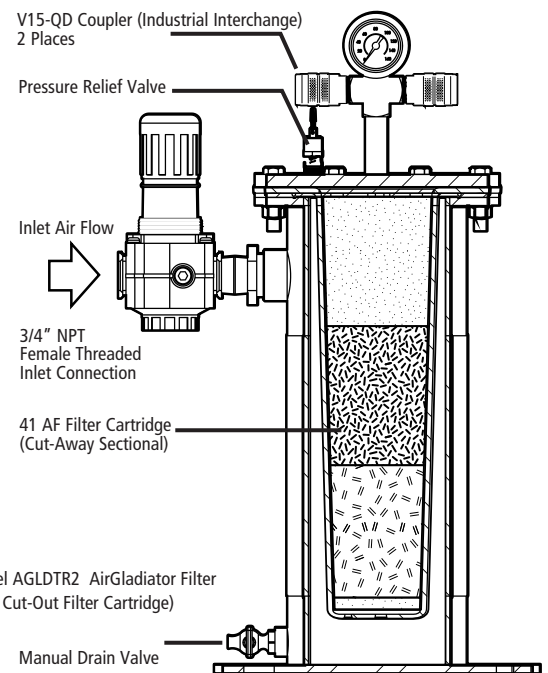

**Figure 2** Model AGLDTR2 AirGladiator Filter (Side View with Cut-Out Filter Cartridge)

# AirGladiator Airline Filters

## User Manual

---

### Warranty Information

Bullard warrants to the original purchaser that the Airline Filter is free of defects in materials and workmanship under normal use and service for a period of one (1) year from the date of manufacture. Under this warranty, Bullard's obligation is limited to repairing or replacing, at its option, articles that are returned within the warranty period and that, after examination, are shown to Bullard's satisfaction to be defective, subject to the following limitations:

- a) Airline Filter must be returned to Bullard with shipping charges prepaid.
- b) Airline Filter must not be altered from its original factory configuration.
- c) Airline Filter must not have been misused, abused or damaged in storage or transit.

In no event shall Bullard be responsible for damages resulting from loss of use or other indirect, incidental, consequential or special costs, expenses or damages incurred by the purchaser, notwithstanding that Bullard has been advised of the possibility of such damages.

ANY IMPLIED WARRANTIES, INCLUDING WARRANTIES OF MERCHANTABILITY AND FITNESS FOR PARTICULAR PURPOSE, ARE LIMITED TO ONE (1) YEAR FROM THE DATE THE AIRLINE FILTER WAS MANUFACTURED.

The above limitations or exclusions may not apply in all states. Some states do not allow the exclusion or limitation of incidental or consequential damages, or allow limitations on how long an implied warranty lasts. This warranty gives you specific legal rights, and you may have other rights which vary between states.

### RETURN AUTHORIZATIONS

Contact Customer Service to obtain written permission to return product. Airline Filters cannot be returned without written permission. Material returned for credit will be subject to factory inspection. Current products or products under warranty will be subject to a restocking charge. Returned articles should be sent to Bullard with shipping charges prepaid.

<b>California Proposition 65 ▲ WARNING</b>
--

Cancer and Reproductive Harm - <a href="http://www.P65Warnings.ca.gov">www.P65Warnings.ca.gov</a> .
---

## Specifications

Airline Filter	AGLDTR1	AGLDTR2	AGLDTR6
Max. Air Flow Rate	100 cfm* (2830 lpm)	75 cfm (2120 lpm)	75 cfm (2120 lpm)
Inlet Connection	1" NPT (Fem.)	1" NPT (Fem.)	1" NPT (Fem.)
Outlet Connection	1 outlet 3/8" NPT (Fem.)	2 outlets 3/8" NPT (Fem.)	6 outlets 3/8" NPT (Fem.)
Relief Valve	125 psig (8.6 bar)	125 psig (8.6 bar)	125 psig (8.6 bar)
Tank Diameter	5 1/2" (14 CM)	5 1/2" (14 CM)	5 1/2" (14 CM)
Height	16" (40.6 CM)	22" (55.9 CM)	18.5" (47 CM)
Weight	26 LBS. (11.8 KG)	29 LBS. (13.2 KG)	32 LBS. (14.5 KG)

\*At maximum recommended pressure of 100 psig (6.9 bar)

## Ordering Information

CATALOG NUMBER	DESCRIPTION	CATALOG NUMBER	DESCRIPTION
<b>Bullard Airline Filters</b>		<b>Replacement Parts</b>	
<b>AGLDTR1</b>	Single-outlet filter with relief value	<b>41AF</b>	Replacement filter cartridge
<b>AGLDTR2</b>	2-outlet filter with pressure gauge, relief valve, pressure regulator, and hose adapter fitting	<b>41PRV</b>	Pressure Relief Valve for. Set at 125 psig (8.6 bar).
<b>AGLDTR6</b>	6-outlet filter with pressure gauge, relief valve, pressure regulator, and hose adapter fitting	<b>41RG</b>	Pressure Gauge for all AirGladiator Series filters
		<b>41P6R</b>	41P6 Inlet Pressure Regulator Replacement Kit

**Bullard Center**  
2421 Fortune Drive  
Lexington, KY 40509 • USA  
877-BULLARD (285-5273)  
Tel: +1-859-234-6616  
Fax: +1-859-246-0243

**Americas Operations**  
1898 Safety Way  
Cynthiana, KY 41031 • USA  
877-BULLARD (285-5273)  
Tel: +1-859-234-6616  
Fax: +1-859-234-8987

**Bullard GmbH**  
Dieselstrasse 8a  
53424 Remagen • Germany  
Tel: +49-2642 999980  
Fax: +49-2642 9999829

**Bullard Asia-Pacific Pte. Ltd.**  
LHK Building  
701, Sims Drive, #04-03  
Singapore 387383  
Tel: +65-6745-0556  
Fax: +65-6745-5176



©2022 Bullard. All rights reserved.  
Teflon is a registered trademark  
of E.I. DuPont de Nemours Co.

60810012674A (0222)

Bullard AirGladiator Filters can be used in conjunction with other compressor safeguards to supply cleaner air to airline respirators. They can also be used to supply drier, cleaner air to pneumatic tools and systems. The Bullard AirGladiator Filters can be used to remove water, oil, odors and organic vapors so that cleaner air is delivered to workers or equipment.

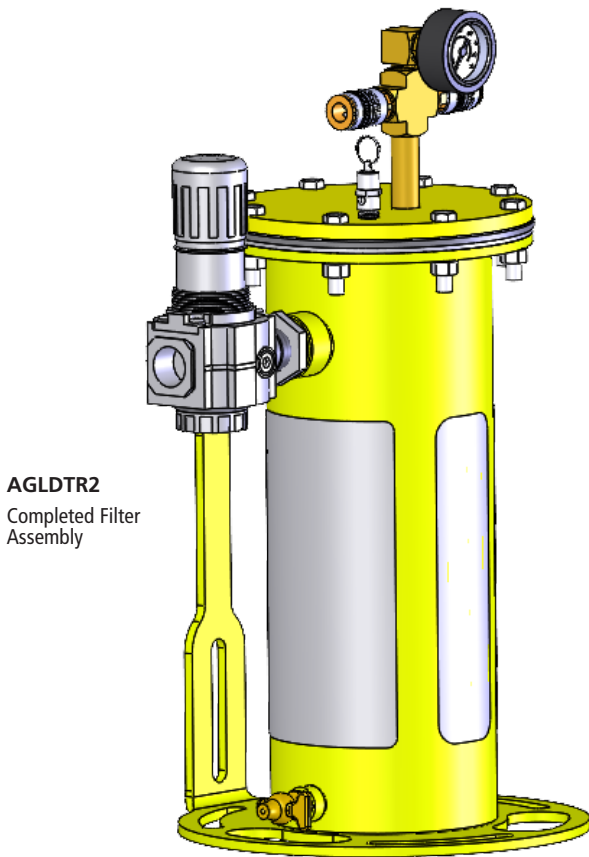

**AGLDTR2**  
Completed Filter Assembly

### ▲ WARNING

The AirGladiator filters do not remove carbon monoxide and other toxic gases. Review and observe all pertinent federal and state safety regulations in conjunction with airline respirators. Failure to observe safety regulations or improper use of Bullard Airline Filters could result in death or serious injury.

## Set-Up of AirGladiator Filter:

### 1. Location:

Select a flat, stable location to mount the filter. Bolt the filter in position using the mounting base. For wall mount applications, the filter carrying handle is designed for mounting the filter to a wall or steel beam.

### 2. Assembly

Three (3) separate sub-assembly parts have been shipped with the filter. Each sub-assembly needs to be installed onto the filter in order to complete the AirGladiator Filter Assembly before it is connected to the Compressed Air Supply Piping.

- Dupont™ Teflon® tape or thread sealant can be used to ensure tight-fitting connections (No Air Leakage) before installation of all these sub-assembly parts.)
- Inlet Air - Pressure Regulator has an 1" NPT Male Connector which must be threaded into the AirGladiator Filter's 1" NPT Female Connector.
- Outlet Air - Piping Assembly has a 3/8" NPT Male connector which must be threaded into the AirGladiator Filter's 3/8" NPT Female Connector on Top of the Filter Flange.
- Pressure Gauge for Outlet Air has an 1/4" NPT Male Back Connector which must be threaded into the 1/4" NPT Female Connector in the Top Bushing of the Outlet Air Piping.

### 3. Connections

Connect compressor hose or piping to Inlet Air - Pressure Regulator (3/4" NPT Female). Connect the respirator system or pneumatic tool airline hose to the Quick Disconnect Coupling on the Outlet Air Piping. Tighten all piping connections to prevent air leaks and/or air pressure loss.

### ▲ WARNING

When using a respirator, do not connect the filter to any air source unless you are certain it supplies breathable air. Failure to ensure breathable air source could result in death or serious injury.

### California Proposition 65 ▲ WARNING

Cancer and Reproductive Harm - [www.P65Warnings.ca.gov](http://www.P65Warnings.ca.gov).

Three (3) Sub-Assembly Parts

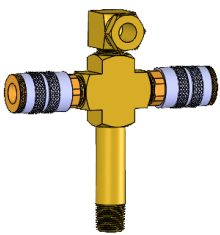

Outlet Air Piping Assembly

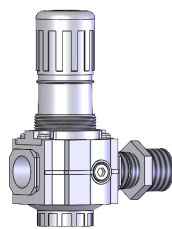

Inlet Air - Pressure Regulator

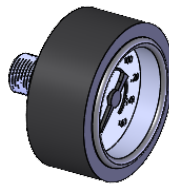

Pressure Gauge

### ⓘ NOTE

When reinstalling or replacing the 41AF Filter Cartridge, tighten by hand in a crossing (star) bolt pattern. Then, secure the bolts by torquing each bolt to a minimum of 20 lbf-ft using the same crossing (star) pattern.

**Bullard Center**  
2421 Fortune Drive  
Lexington, KY 40509 • USA  
877-BULLARD (285-5273)  
Tel: +1-859-234-6616  
Fax: +1-859-246-0243

**Americas Operations**  
1898 Safety Way  
Cynthiana, KY 41031 • USA  
877-BULLARD (285-5273)  
Tel: +1-859-234-6616  
Fax: +1-859-234-8987

**Bullard GmbH**  
Dieselstrasse 8a  
53424 Remagen • Germany  
Tel: +49-2642 999980  
Fax: +49-2642 9999829

**Bullard Asia-Pacific Pte. Ltd.**  
LHK Building  
701, Sims Drive, #04-03  
Singapore 387383  
Tel: +65-6745-0556  
Fax: +65-6745-5176



©2022 Bullard. All rights reserved.  
Teflon is a registered trademark  
of E.I. DuPont de Nemours Co.

60810012674A (0222)

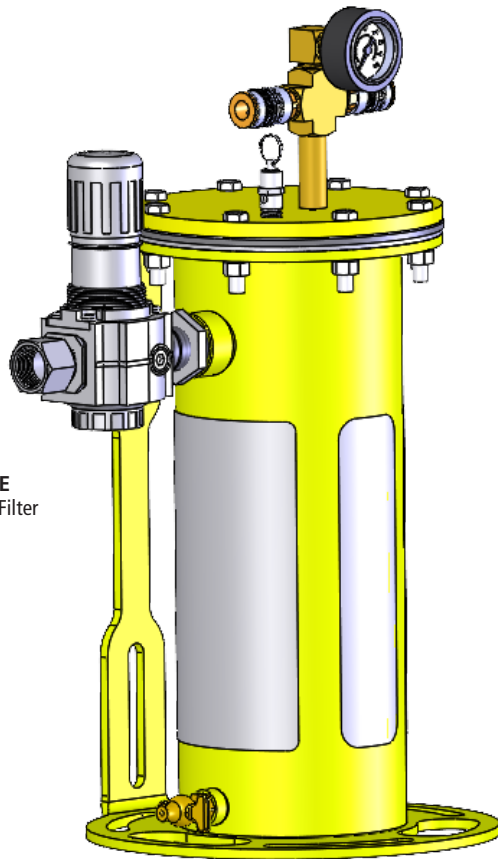

**AGLDTR2E**  
Completed Filter  
Assembly

Bullard AirGladiator Filters can be used in conjunction with other compressor safeguards to supply cleaner air to airline respirators. They can also be used to supply drier, cleaner air to pneumatic tools and systems. The Bullard AirGladiator Filters can be used to remove water, oil, odors and organic vapors so that cleaner air is delivered to workers or equipment.

### ▲ WARNING

The AirGladiator filters do not remove carbon monoxide and other toxic gases. Review and observe all pertinent federal and state safety regulations in conjunction with airline respirators. Failure to observe safety regulations or improper use of Bullard Airline Filters could result in death or serious injury.

## Set-Up of AirGladiator Filter:

### 1. Location:

Select a flat, stable location to mount the filter. Bolt the filter in position using the mounting base. For wall mount applications, the filter carrying handle is designed for mounting the filter to a wall or steel beam.

### 2. Assembly

Three (3) separate sub-assembly parts have been shipped with the filter. Each sub-assembly needs to be installed onto the filter in order to complete the AirGladiator Filter Assembly before it is connected to the Compressed Air Supply Piping.

- Dupont™ Teflon® tape or thread sealant can be used to ensure tight-fitting connections (No Air Leakage) before installation of all these sub-assembly parts.
- Inlet Air - Pressure Regulator has an 1" NPT Male Connector which must be threaded into the AirGladiator Filter's 1" NPT Female Connector.
- Outlet Air - Piping Assembly has a 3/8" NPT Male connector which must be threaded into the AirGladiator Filter's 3/8" NPT Female Connector on Top of the Filter Flange.
- Pressure Gauge for Outlet Air has an 1/4" NPT Male Back Connector which must be threaded into the 1/4" NPT Female Connector in the Top Bushing of the Outlet Air Piping.

### 3. Connections

Connect compressor hose or piping to Inlet Air - Pressure Regulator (3/4" BSPT Female). Connect the respirator system or pneumatic tool airline hose to the Quick Disconnect Coupling on the Outlet Air Piping. Tighten all piping connections to prevent air leaks and/or air pressure loss.

Three (3) Sub-Assembly Parts

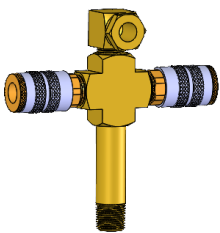

Outlet Air Piping Assembly

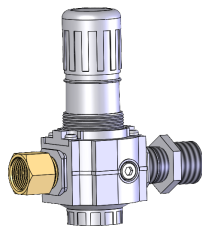

Inlet Air - Pressure Regulator  
with the EN Adapter installed

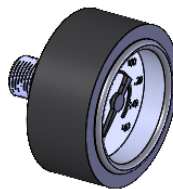

Pressure Gauge

### ▲ WARNING

When using a respirator, do not connect the filter to any air source unless you are certain it supplies breathable air. Failure to ensure breathable air source could result in death or serious injury.

### California Proposition 65 ▲ WARNING

Cancer and Reproductive Harm - [www.P65Warnings.ca.gov](http://www.P65Warnings.ca.gov).

### ⓘ NOTE

When reinstalling or replacing the 41AF Filter Cartridge, tighten by hand in a crossing (star) bolt pattern. Then, secure the bolts by torquing each bolt to a minimum of 20 lbf-ft using the same crossing (star) pattern.

**Bullard Center**  
2421 Fortune Drive  
Lexington, KY 40509 • USA  
877-BULLARD (285-5273)  
Tel: +1-859-234-6616  
Fax: +1-859-246-0243

**Americas Operations**  
1898 Safety Way  
Cynthiana, KY 41031 • USA  
877-BULLARD (285-5273)  
Tel: +1-859-234-6616  
Fax: +1-859-234-8987

**Bullard GmbH**  
Dieselstrasse 8a  
53424 Remagen • Germany  
Tel: +49-2642 999980  
Fax: +49-2642 9999829

**Bullard Asia-Pacific Pte. Ltd.**  
LHK Building  
701, Sims Drive, #04-03  
Singapore 387383  
Tel: +65-6745-0556  
Fax: +65-6745-5176



©2022 Bullard. All rights reserved.  
Teflon is a registered trademark  
of E.I. DuPont de Nemours Co.

60810012674A (0222)

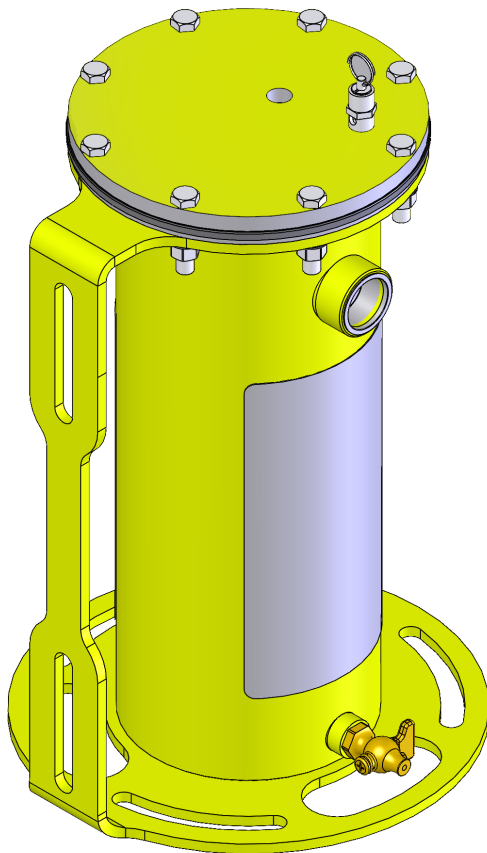

AGLDTR1 Completed Filter Assembly

Bullard AirGladiator Filters can be used in conjunction with other compressor safeguards to supply cleaner air to airline respirators. They can also be used to supply drier, cleaner air to pneumatic tools and systems. The Bullard AirGladiator Filters can be used to remove water, oil, odors and organic vapors so that cleaner air is delivered to workers or equipment.

### **▲ WARNING**

The AirGladiator filters do not remove carbon monoxide and other toxic gases. Review and observe all pertinent federal and state safety regulations in conjunction with airline respirators. Failure to observe safety regulations or improper use of Bullard Airline Filters could result in death or serious injury.

## Set-Up of AirGladiator Filter:

### 1. Location:

Select a flat, stable location to mount the filter. Bolt the filter in position using the mounting base. For wall mount applications, the filter carrying handle is designed for mounting the filter to a wall or steel beam.

### 2. Assembly

This Filter is shipped completely assembled at the factory. This AirGladiator Filter Assembly has an INLET AIR Connector and OUTLET AIR Connector ready for the User's Compressed Air System. This Filter has a pre-set (125 psi) pressure relief valve connected near the Outlet Air Connector to prevent over-pressuring the Filter.

- Dupont™ Teflon® tape or thread sealant can be used to ensure tight-fitting connections (No Air Leakage) before installation of any compressed air items.
- Inlet Air Connector on this Filter is a 1" NPT Female Connector - A "User-Supplied" Pressure Regulator is recommended to be installed at this connection.
- Outlet Air Connector on this Filter is a 3/8" NPT Female Connector - A "User-Supplied" Pressure Gauge is recommended to be installed at this connection along with any Outlet Air Piping System.

### 3. Connection

Connect compressor hose or piping to Inlet Air and Outlet Air Connections based on the "User-Supplied" Compressed Air System. Tighten all piping connections to prevent air leaks and/or air pressure loss.

### **▲ WARNING**

When using a respirator, do not connect the filter to any air source unless you are certain it supplies breathable air. Failure to ensure breathable air source could result in death or serious injury.

### **California Proposition 65 ▲ WARNING**

Cancer and Reproductive Harm - [www.P65Warnings.ca.gov](http://www.P65Warnings.ca.gov).

### **NOTE**

When reinstalling or replacing the 41AF Filter Cartridge, tighten by hand in a crossing (star) bolt pattern. Then, secure the bolts by torquing each bolt to a minimum of 20 lbf-ft using the same crossing (star) pattern.

**Bullard Center**  
2421 Fortune Drive  
Lexington, KY 40509 • USA  
877-BULLARD (285-5273)  
Tel: +1-859-234-6616  
Fax: +1-859-246-0243

**Americas Operations**  
1898 Safety Way  
Cynthiana, KY 41031 • USA  
877-BULLARD (285-5273)  
Tel: +1-859-234-6616  
Fax: +1-859-234-8987

**Bullard GmbH**  
Dieselstrasse 8a  
53424 Remagen • Germany  
Tel: +49-2642 999980  
Fax: +49-2642 9999829

**Bullard Asia-Pacific Pte. Ltd.**  
LHK Building  
701, Sims Drive, #04-03  
Singapore 387383  
Tel: +65-6745-0556  
Fax: +65-6745-5176



©2022 Bullard. All rights reserved.  
Teflon is a registered trademark  
of E.I. DuPont de Nemours Co.  
60810012674A (0222)

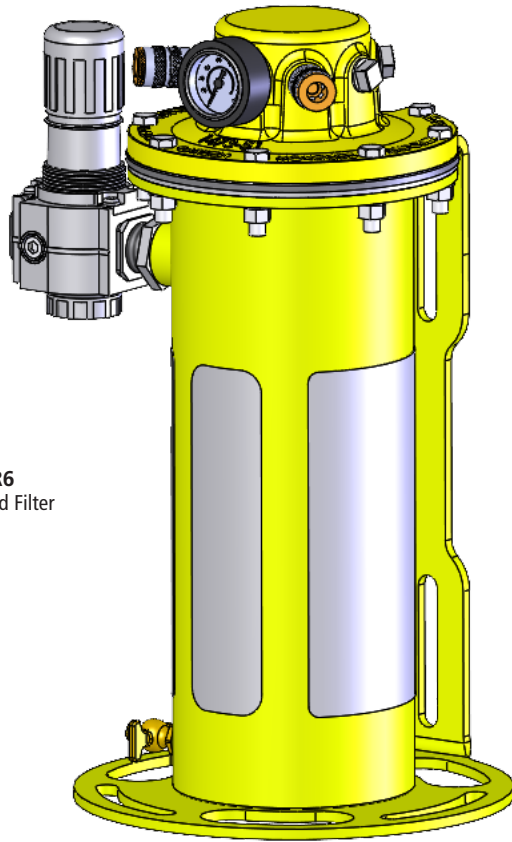

**AGLDTR6**  
Completed Filter  
Assembly

Three (3) Sub-Assembly Parts

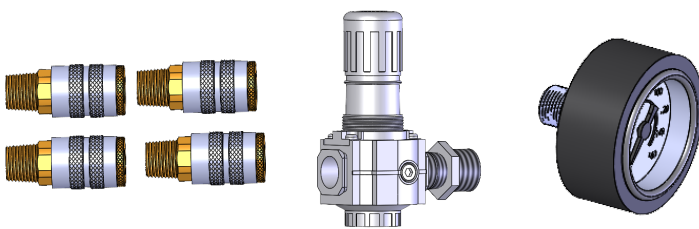

Additional Quick Disconnect  
Couplings

Inlet Air - Pressure Regulator

Pressure Gauge

**NOTE**

When reinstalling or replacing the 41AF Filter Cartridge, tighten by hand in a crossing (star) bolt pattern. Then, secure the bolts by torquing each bolt to a minimum of 20 lbf-ft using the same crossing (star) pattern.

Bullard AirGladiator Filters can be used in conjunction with other compressor safeguards to supply cleaner air to airline respirators. They can also be used to supply drier, cleaner air to pneumatic tools and systems. The Bullard AirGladiator Filters can be used to remove water, oil, odors and organic vapors so that cleaner air is delivered to workers or equipment.

**▲ WARNING**

The AirGladiator filters do not remove carbon monoxide and other toxic gases. Review and observe all pertinent federal and state safety regulations in conjunction with airline respirators. Failure to observe safety regulations or improper use of Bullard Airline Filters could result in death or serious injury.

### Set-Up of AirGladiator Filter:

**1. Location:**

Select a flat, stable location to mount the filter. Bolt the filter in position using the mounting base. For wall mount applications, the filter carrying handle is designed for mounting the filter to a wall or steel beam.

**2. Assembly**

Two (2) separate sub-assembly parts have been shipped with the filter. Each sub-assembly needs to be installed onto the filter in order to complete the AirGladiator Filter Assembly before it is connected to the Compressed Air Supply Piping.

- Dupont™ Teflon® tape or thread sealant can be used to ensure tight-fitting connections (No Air Leakage) before installation of all these sub-assembly parts.)
- Inlet Air - Pressure Regulator has an 1" NPT Male Connector which must be threaded into the AirGladiator Filter's 1" NPT Female Connector.
- Pressure Gauge for Outlet Air has an 1/4" NPT Male Back Connector which must be threaded into the 1/4" NPT Female Connector on the Top Flange of the Filter Outlet Air Connection Area.
- Additional Quick Disconnect Couplings have been shipped with this AirGladiator Filter. These extra Couplings allow the user to install a maximum of Six (6) Quick Disconnect Couplings around the Top Flange of the Filter.

**3. Connection**

Connect compressor hose or piping to Inlet Air - Pressure Regulator (3/4" NPT Female). Connect the respirator system or pneumatic tool airline hose to the Quick Disconnect Coupling on the Outlet Air Top Flange. Tighten all piping connections to prevent air leaks and/or air pressure loss.

**▲ WARNING**

When using a respirator, do not connect the filter to any air source unless you are certain it supplies breathable air. Failure to ensure breathable air source could result in death or serious injury.

**California Proposition 65 ▲ WARNING**

Cancer and Reproductive Harm - [www.P65Warnings.ca.gov](http://www.P65Warnings.ca.gov).

**Bullard Center**  
2421 Fortune Drive  
Lexington, KY 40509 • USA  
877-BULLARD (285-5273)  
Tel: +1-859-234-6616  
Fax: +1-859-246-0243

**Americas Operations**  
1898 Safety Way  
Cynthiana, KY 41031 • USA  
877-BULLARD (285-5273)  
Tel: +1-859-234-6616  
Fax: +1-859-234-8987

**Bullard GmbH**  
Dieselstrasse 8a  
53424 Remagen • Germany  
Tel: +49-2642 999980  
Fax: +49-2642 9999829

**Bullard Asia-Pacific Pte. Ltd.**  
LHK Building  
701, Sims Drive, #04-03  
Singapore 387383  
Tel: +65-6745-0556  
Fax: +65-6745-5176



©2022 Bullard. All rights reserved.  
Teflon is a registered trademark  
of E.I. DuPont de Nemours Co.

60810012674A (0222)