

**“Save
Your
Breath
With
NST[®]”**
MODERN SAFETY TECHNIQUES

11388 Breininger Rd. Phone: (800) 542-6646
P.O. Box 87 (888) mod-safe
Hicksville, OH 43526 (419) 542-6645
Website: www.modsafe.com Fax: (419) 542-6475
Email: modsafe@bright.net

**SERVICE MANUAL
MODEL BA200AMST-S1
BREATHING AIR PANEL**

Distributed By:



2717 Tobey • Indianapolis, IN 46219
(317) 545-0665 • FAX (317) 545-0670 • (800) 800-0665
www.idsblast.com

WARNING: Do not attempt to operate this equipment without first reading and understanding the service manual enclosed with this device.

GENERAL OPERATION MANUAL

WARNING: The MST Breathing Air Panel Model BA200AMST-S1:

- 1) WILL NOT remove Carbon Monoxide.
- 2) SHOULD NOT be used when the air entering the filtering system is oxygen deficient. The MST Breathing Air Panel will not increase the oxygen content of the air.
- 3) SHOULD NOT be used in an Immediately Dangerous to Life and Health Atmosphere (IDLH) unless it is used in conjunction with a Back-Up Escape system or a supplied air Self-Contained Breathing Apparatus (SCBA), where applicable.
- 4) SHOULD NOT have air inlet pressure greater than 150 PSIG static (10.4bar). Personal injury could result.
- 5) SHOULD NOT have air outlet pressure that exceeds Manufacturers' Respirator/Hose Assembly pressure requirements. Personal injury could result.
- 6) CARBON MONOXIDE MONITOR will alarm if Carbon Monoxide levels exceed requirement for Grade "D" Breathing Air set forth by OSHA/CSA. If alarm should sound, remove respirator or activate SCBA and immediately move to safe breathable atmosphere. Have the proper qualified personnel examine the equipment and make the appropriate corrections before using again.

The MST Breathing Air Panel is a Four Stage Filtration System designed to remove or reduce select contaminants found in compressed air lines. The Breathing Air Panel can be connected directly to shop air from a standard compressed air source to help provide breathing quality air to face masks, helmets, hoods and other supplied air breathing apparatus.

GENERAL FILTER SYSTEM DESCRIPTION

(Refer to Figure No.1)

Air entering the MST Breathing Air Panel at the inlet (A) is usually contaminated with oil, water, dirt, rust, scale and gaseous Hydrocarbons. As the air passes through the First Stage (B), particulate and liquid contaminates will be trapped-coalesced out (0.7 micron max solids and liquids down to 2.0 microns at an efficiency rating of 95%). The liquids are trapped and expelled through the Automatic Float Drain (C). The Differential Pressure Gauge (DPG) at (D) will indicate when element requires changing. The Second Stage (E) traps and retains particulate matter down to 0.3 microns. As air enters the Third Stage (F), liquid contaminates are coalesced down to 0.75 microns with an efficiency rating of 99.97% (meets Underwriters Laboratories Specification UL 586 for High Efficiency, Particulate, Air Filter Units). The liquids are trapped and expelled through the Automatic Float Drain (G). The "DPG" at (H) will indicate when element requires changing. The Fourth Stage (I) contains odor absorbing activated charcoal which collects various Hydrocarbons (such as oil fumes, benzene, etc.). Any liquids (should not be any) are trapped and expelled through Automatic Float Drain at (J). The "DPG" at (K) will indicate when all filters require replacement. The air is then passed through the Air Pressure Regulator (L), which is used to adjust the air pressure going to the respiratory system. A sample of the filtered air is taken at (M) and passed through the Carbon Monoxide Monitor (N). The Carbon Monoxide Monitor continuously checks the carbon monoxide levels per OSHA/CSA requirements and digitally displays the amount present in PPM (Parts Per Million). An audible and visual alarm will alert operators if levels of carbon monoxide exceed OSHA/CSA requirements.

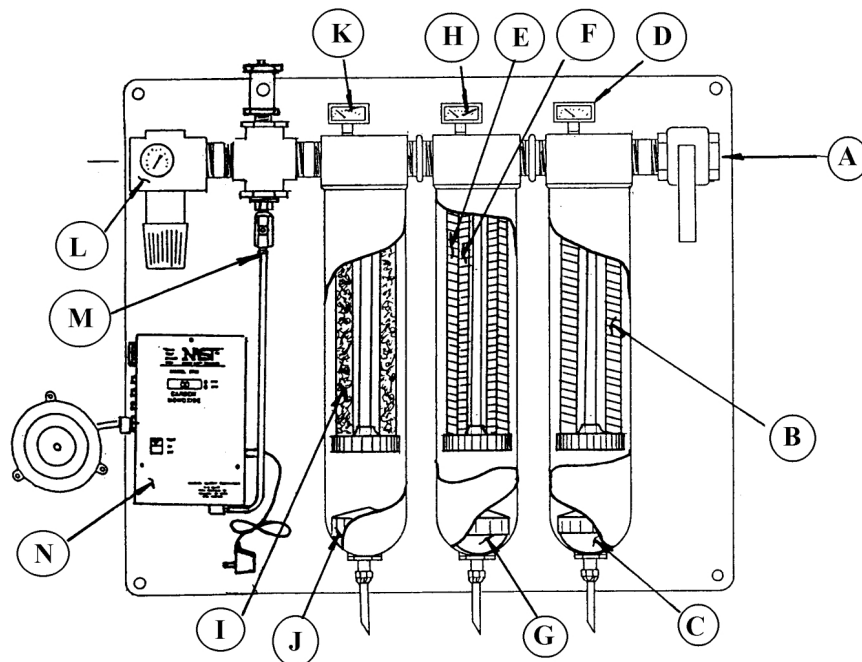

FIGURE NO.1

GENERAL INSTRUCTIONS

The MST BA200AMST-S1 Breathing Air Panel, a compressed air purifier, when used in accordance with the following instructions, will remove or reduce selected contaminants from compressed air lines.

WARNING: The MST Breathing Air Panel BA200AMST-S1 should not be used when the air entering the filter is oxygen deficient (air with a low oxygen content). The MST Breathing Air Panel will not increase the oxygen content of oxygen deficient air.

MST, Inc. strongly recommends that a complete safety program be initiated to ensure that the respiratory air is in compliance with all OSHA standards and other applicable laws regulating the use of supplied air respiratory systems. MST, Inc. recommends that the air quality be tested upon installation and periodically re-tested to ensure that the minimum requirements for breathing air are maintained.

WARNING: The MST Breathing Air Panel BA200AMST-S1 will not remove Carbon Monoxide.

This system is to be used only by trained qualified personnel in accordance with a respirator program as outlined in OSHA Regulation 29 CFR 1910.134(b). MST, Inc. will not assume any liability for accidents or personal injury resulting from the improper use of this equipment.

The air supply entering The MST Breathing Air Panel must meet the following criteria to ensure maximum efficiency of the MST filter system:

- 1) Temperature range should be between 35-150°F (2-65°C). Conditioning equipment may be necessary, prior to the filter, to achieve this temperature range.

WARNING: Maximum pressure supplied to this unit IS NOT to exceed 150 PSIG. Personal injury could result.

The Regulator 80214 is used to set the air pressure supplied to the breathing air system and to maintain the correct air exchange in the operators' respirators. Consult instructions on your particular breathing mask or hood for pressure requirements per NIOSH.

WARNING: DO NOT Exceed mask and hose assembly manufacturer's requirements for outlet pressure. Personal injury could result.

The filter cartridges used in the Breathing Air Panel Model BA200AMST-S1 have an average life expectancy of (6) six months, (depending on the quality of the air in your compressed air lines) under normal conditions. If liquid is being expelled out from the Fourth Stage Automatic Float Drain, MST, Inc. recommends changing all (3) filter cartridges.

WARNING: If the Monitor's alarm should sound, remove mask or hood immediately and move to a safe breathable atmosphere. Have a proper qualified personnel examine the equipment and make the appropriate corrections before using again.

The Carbon Monoxide Alarm will sound to alert the operator that a problem has developed. The Monitor Alarm will sound due to one or more of the following conditions:

- A) Carbon Monoxide levels exceeding a pre-determined alarm set level is passing through the Breathing Air Panel. The Breathing Air Panel does not remove or reduce the Carbon Monoxide content in the compressed air. Examine the air compressor, the air compressor intake air quality, and the complete system. Have the proper qualified personnel make the appropriate corrections before using again.
- B) Monitor out of Calibration. Calibrate Carbon Monoxide Monitor as outlined in the MST Monitor Model 5700 Information Manual.
- C) The monitor's carbon monoxide sensor may be bad. See the MST Monitor Model 5700 manual for further maintenance on monitor.

SERVICE INSTRUCTIONS

(Refer to Figure No.2)

**WARNING: Always turn off air supply and bleed air pressure before disassembling unit or
 SERIOUS INJURY COULD RESULT.**

To replace all or individual filter cartridges in the Breathing Air Panel Model BA200AMST-S1, follow these steps:

1. FIRST STAGE ELEMENT REPLACEMENT

Element change is required when the Differential Pressure Gauge indicates a 6-10 PSID, 12 PSID max.

- A) First unscrew Bowl Assembly (1). A strap wrench may be required to break bowl, O-ring/manifold seal. Clean bowl ass'y in mild soap and water and blow dry with low pressure air.
- B) Remove Coalescing Element (2) by unscrewing End Cap Retaining Nut (3).
- C) Inspect the Filter Manifold (4) for dirt/contaminates and clean as required. Inspect O-ring (5) for cuts etc. and replace if required. Clean and apply light film of petroleum jell on O-ring before re-installing.
- D) Install new Coalescing Element and tighten End Cap Retaining Nut. Be sure Element is seated squarely on Manifold's boss and End Cap.
- E) Apply light film of petroleum jell on Bowl's beveled edge and threads to provide good seal. HAND TIGHTEN ONLY to Manifold.
- F) Dispose of used Coalescing Element according to local, state and federal regulations.

2. PREFILTER SECOND/THIRD DUAL STAGE ELEMENT REPLACEMENT

Prefilter Dual Stage Element change is required when the Differential Pressure Gauge indicates an 8-10 PSID.

- A) Replace the Prefilter Dual Stage Element (6) using the above "First Stage Element" replacement instructions.
- B) Dispose of used Prefilter Dual Stage Element according to local, state and federal regulations.

3. FOURTH STAGE ADSORBER ELEMENT REPLACEMENT

The Adsorber Element change is required when the Differential Pressure Gauge indicates ANY PRESSURE DROP, or if any odor is detected by operator.

NOTE: If any liquids are being expelled out of the Fourth Stage Auto Drain, replace All 3 Elements.

- A) Replace the Adsorber Element (7) using the above "First Stage Element" replacement instructions.
- B) Dispose of used Adsorber Element according to local, state and federal regulations.

4. FINAL CHECK

- A) Pressurize system and check for leaks.
- B) Flush system with compressed air for five (5) minutes.
- C) Calibrate Carbon Monoxide Monitor as outlined in MST Monitor Model 5700 Information Manuals.

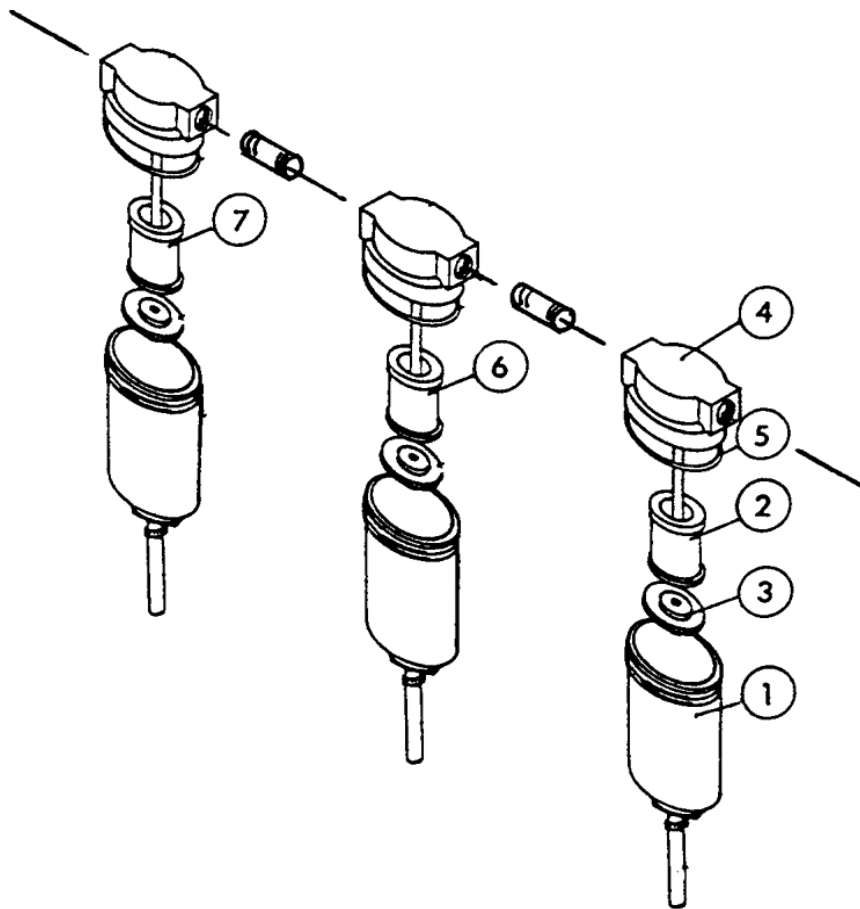

FIGURE NO.2

RECORD KEEPING

Record all periodical air quality checks, filter cartridge change intervals and any other service performed on the MST Breathing Air Panel.

MST INC. SHALL NOT BE LIABLE FOR ANY INJURY, LOSS OR DAMAGE, (DIRECT OR CONSEQUENTIAL), ARISING OUT OF THE USE OF OR THE INABILITY TO USE THIS PRODUCT, BEYOND THE REPLACEMENT OF DEFECTIVE MATERIALS OR WORKMANSHIP. USER OF SUPPLIED AIR RESPIRATORS SHOULD EVALUATE THEIR OWN PARTICULAR APPLICATION AND PERFORM THEIR OWN TESTS FOR AIR QUALITY TO DETERMINE THE SUITABILITY FOR USE OF THIS PRODUCT.

For further information, or questions about service or maintenance care of this unit, contact your local distributor or MST, Inc. at (800) 542-6646.

MST, INC.
SERVICE RECORD
BREATHING AIR PANEL MODEL BA200AMST-S1

DATE OF SERVICE	SERVICE PERFORMED

**SPECIFICATIONS
BREATHING AIR PANEL
MODEL BA200AMST-S1**

INLET PRESSURE (MAX.)	150 PSIG STATIC (10.4 BAR)
RATED AIR FLOW (MAX.)	200 SCFM (94.4L/s)
OPERATING PRESSURE	100 PSIG DYNAMIC (6.9 BAR)
OUTLET PRESSURE RANGE	0-125 PSIG (0-8.6 BAR)
OPERATING TEMP.RANGE	35-150°F (2-65°C)
OUTSIDE DIMENSIONS	36"L X 36"W X 7"D (915mm X 915 mm X 178 mm)
WEIGHT (INCLUDING MONITOR)	71 Lbs (32.2 kg.)
REPLACEMENT FILTER ELEMENTS	FIRST STAGE ELEMENT <u>80400</u> SECOND/THIRD STAGE ELEMENT <u>80238B</u> FOURTH STAGE ELEMENT <u>80401</u>

BREATHING AIR PANEL MODEL BA200AMST-S1 PARTS

- | | | | |
|-----|--|-----|-------------------------------------|
| 1) | 80221,(1), 1 1/4" Ball Valve | 13) | 80324,(1), 3/4" x 125 PSI PRV |
| 2) | S603-075,(5), BR Nipple 1 1/4" x 2" | 14) | S638-011,(1), 3/4" x 1/2" R.Bushing |
| 3) | 80409,(1), Coalescing-200 SCFM | 15) | S638-015,(1), 1/2" x 1/8" R.Bushing |
| 4) | 80051,(4), Tube Locking Collar | 16) | S603-001,(1), 1/8" BR Nipple |
| 5) | S710-005,(3), Drain Tube | 17) | 80016,(1), Sample Valve |
| 6) | 80113,(1), Prefilter-200 SCFM | 18) | 80076,(1), Pressure Gauge |
| 7) | 80410,(1), Adsorber-200 SCFM | 19) | 80214,(1), Regulator |
| 8) | 80422,(3), Differential Pressure Gauge | 20) | 80339,(1), Monitor Bracket |
| 9) | 80428,(2), Mount Bracket Ass'y | 21) | 8012701,(1), MST 'CO' Monitor |
| 10) | 80429,(4), Mount Bracket Bolts | 22) | 8008403,(1), Remote Alarm |
| 11) | 80423,(1), Cross 1 1/4" | 23) | 80247,(1), 110 VAC Adapter |
| 12) | S638-017,(2), 1 1/4" x 3/4" R. Bushing | | |

