



HURRICANE 755

HURRICANE 755 SPECIFICATIONS

- **TRAILER MOUNTED** Chassis - tandem 8000# axles, 4" x 6" rectangular tube frame with four, 8 lug P225R-16 ten ply, steel belted radials. DOT lighting with electric brakes. Enclosed trailer light wiring harness, sealed junction boxes.
- **POWER SOURCE** John Deere turbo-charged diesel engine, 6.8 L, 225 HP @2400 RPM.
- **P.T.O (clutch)** Double disc, 11.5" with iron plates.
- **VACUUM AIR FLOW (blower)** Roots Dresser 3660 CFM capable of 28" Hg, direct drive through flex coupling, with guard.
- **FILTRATION SYSTEM (3-Stage)**
 Stage 1: Cyclonic separation.
 Stage 2: Baghouse / 37 Teflon coated, quick change filter bags with continuous reverse pulse air cleaning.
 Stage 3: Dual high efficiency blower safety filters with dirty filter shut-down system.
- **HYDRAULICS** 3.5 GPM, 2200 PSI, direct drive.
- **ENCLOSURE** Lockable steel shroud over all major components.
- **INSTRUMENT PANEL (fully enclosed)** 12 volt key start, Murphy safety system (low oil pressure/ high water temperature-auto shut down)
 Gauges: oil pressure, water temperature, ammeter, tachometer with hour meter, filter cleaning on/off switch, material vacuum & dump time controls.
- **AIR COMPRESSOR** Direct drive Bendix twin cylinder; water cooled and oil pressure fed. Midland air dryer with electronic heater.
 AMSE certified air tank mounted on vibration isolators. (Provides air to pneumatic controls and the self cleaning filter system)

STANDARD EQUIPMENT

- Paint-one color (custom lettering available)
- Wet or dry operation
- Tool box
- Automatic cone vibrator
- 100 gallon fuel tank
- Adjustable pintle hook
- Emergency stop button

OPTIONS

- Spare tire & carrier
- Cold weather package
- HEPA filtration
- Slide gate discharge
- Auxiliary 50 gallon fuel tank
- Hydraulic lift leg to level trailer
- 16" manhole on baghouse
- High reach package for discharge up to 11'
- Asbestos / hazardous waste package
- Auger in hopper (cone)
- Auxiliary air hose 120 PSI
- Skid mount
- Hydraulic surge brakes
- 200 HP electric motor
- 4 point certified lifting cage
- Flip top baghouse dome

SAFETY FEATURES

- OSHA approved drive guard
- Remote emergency stop button
- Safety struts for baghouse
- Emergency brake away chain
- Wheel chocks
- Optional HEPA filtration
- Electric brakes
- Low oil or high temp engine shutdown
- Dirty filter shut-down system

Distributed By:



2717 Tobey • Indianapolis, IN 46219
 (317) 545-0665 • FAX (317) 545-0670 • (800) 800-0665
 www.idsblast.com

Machine Dimensions On Reverse Side



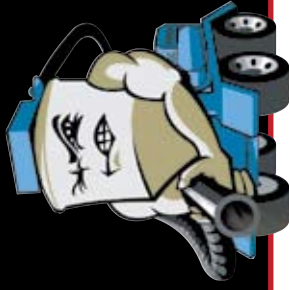

HURRICANE 755

HURRICANE

INDUSTRIAL VACUUM

256"

DIMENSIONS

WIDTH 8'3"
WEIGHT 13,500 lbs.

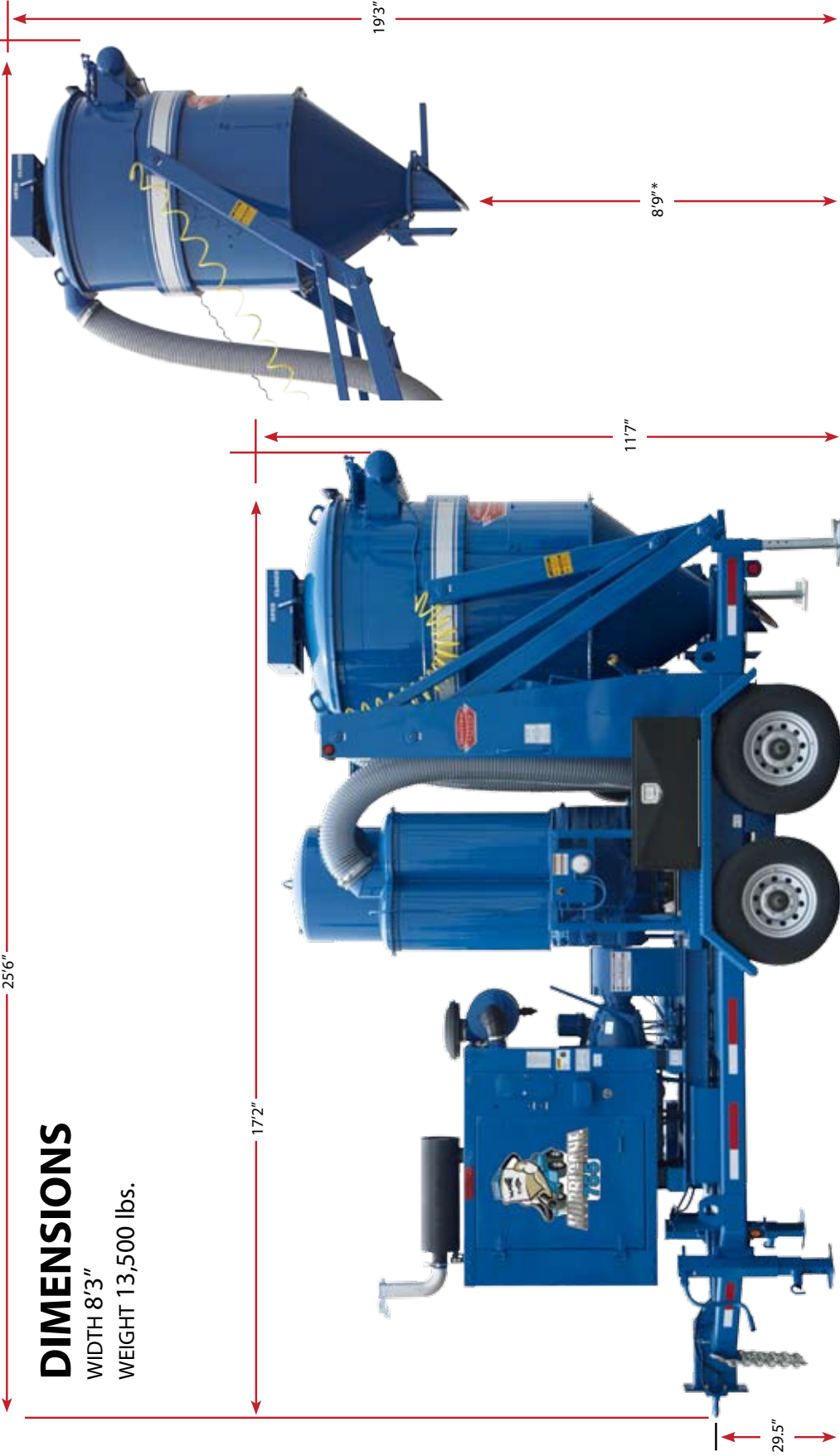

*High reach packages up to 11 feet available.