

Tasca Chair
Permanent Collection

FRAMA

Introduction

- 4 Permanent Collection
 - Furniture
- 5 Tasca Chair
 - Details
 - Technical info
- 8 Contact



Essentials Collection

The Permanent Essentials Collection carries a range of essential pieces that we define as our most utilitarian pieces. The characteristics for this series are to suit essential usages and easily adapt to everyday living situations. The products have a democratic feel and essence to them, that in their practicality and usefulness makes for a high level of agility in different environments.



Tasca Chair

Conceived with timeless materials and a multi-purpose function, for both indoor and outdoor spaces, the Tasca Chair is characterized by modern design simplicity and function. This color-neutral chair is manufactured in aluminum that seamlessly flows from top to bottom. The classic profile of its oval back connects to a slim, perfectly molded seat that is supported by sleek yet sturdy legs.

The chair's pure industrial aesthetic is complemented by the skillful use of aluminum. The choice to use aluminum as the primary material is driven by the appeal of its lightness, comfort, and durability. Tasca's aesthetic and smooth finish blend seamlessly with warm and earthy tones where materials such as wood, timber, clay, soil, and granite play a central role.

Unlike any other furniture made of steel or iron, the chair does not rust, but gracefully ages. With its distinctive silvery look, the Tasca makes a very versatile piece, perfect for every space, creating a fine location to enjoy a moment of peace in which time flies imperceptibly. A chair soft in texture, with a smooth, rounded form that encases the user.

The inspiration behind the Tasca Chair lies in the traditional seating used in small, family-ran, and long-established Portuguese restaurants called "Tasca", typically found in old neighborhoods or away from the city's most crowded areas. The introduction of this piece represents a desire to reinvent a chair that people feel familiar with.



Tasca Chair intends to add personality and practicality to any bistro, canteen, restaurant, living room, or garden.

All units are individually crafted and manufactured in Portugal, in one of the oldest metal furniture factories with more than a century of work experience and crafts tradition.

Pedro Sottomayor

“The more I work in the field of product design, the more I feel we must connect with nature, and we don’t need much more than that.”

Pedro Sottomayor

Pedro is an established designer and the visionary behind Tasca Chair. Originally from Porto in Portugal, Pedro studied product design in Florence. The knowledge he obtained during his stay in Italy helped him establish the principles that guide his approach to design to this present day: beauty, culture, and design awareness, all channeled towards an efficient industrial production. His practice, based in Lisbon since 2009, has become an award-winning studio working for some of the most important Portuguese manufacturers and his work has been recognized internationally. Pedro aims to work towards a timeless legacy of products, mixing contemporary design and heritage, a fine principle for a long-life cycle.

The collaboration



The idea of creating the Tasca Chair was founded by the ambition for a contemporary piece of furniture that accommodates a modern lifestyle. By using quality craftsmanship and innovative industrial production techniques, the chair preserves traditional shapes and forms. Working together with a friend and talented, spirited designer, Frama and Pedro Sottomayor have managed to combine the structural character of architecture with the dynamic nature of collaboration. The result of this collaboration is a durable product shaped by good ideas, technical skills, and the best materials available. Tasca will be entirely produced and manufactured in Portugal, a country Frama values very much for its well-established design traditions, rich culture, and warm-hearted people.

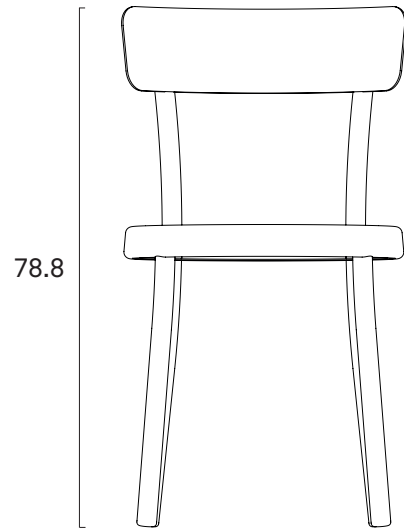
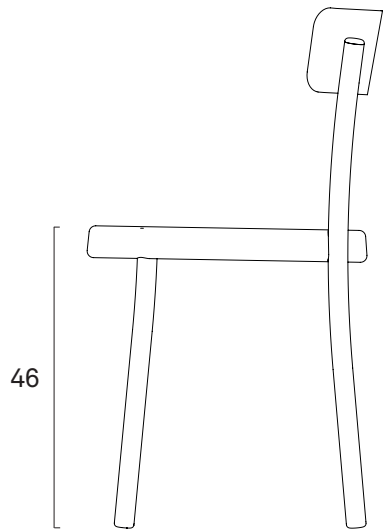
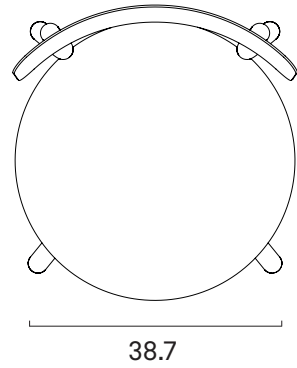

TASCA CHAIR

Product	Chair
Design	Pedro Sottomayor
Origin	Portugal
Materials	Untreated aluminum
Dimensions	H78.8 W43.3 D45
Item number	2032



Online store enquiries
shop@framacph.com

General enquiries
frama@framacph.com

Retail requests and orders
order@framacph.com

Press
press@framacph.com

Business/partnership requests
bc@framacph.com

Project requests
design@framacph.com

Claims
claims@framacph.com

Accounting
accounting@framacph.com.

Address
Frama Head Office
Fredericiagade 57, 1310
Copenhagen, Denmark
+45 3140 6030
CVR 35391355