

RFH Lounge Chair ^{RD8}

Robin Day

1951



RFH Lounge Chair ^{RD8}

Robin Day

1951



H: 69cm / 27in
Seat H: 36cm / 14in
Armrest H: 58cm / 23in

W: 86cm / 34in, D: 66cm / 26in
Seat D: 51cm / 20in

Product description

Lounge Chair

Environment

Indoor

Material
Walnut and beech veneer, powder-coated steel tubing and steel rod, foam. This product has not been treated with any biocides.

Production process
The steel frame is CNC bent, welded together and powder-coated. The back is made from layers of walnut and beech veneer which are form-pressed and cut to shape using a CNC machine. The seat is made from layers of beech veneer glued together and upholstered foam.

Variants
Black & Hallingdal 103, Black & Hallingdal 227

Strength, durability and safety testing
The chair is tested for strength, durability and safety according to: EN 16139 Level 1 (Seating), BIFMA X5.4-2020

Dimensions
H: 69cm / 27in, W: 86cm / 34in, D: 66cm / 26in,
Seat H: 36cm / 14in, Armrest H: 58cm / 23in,
Seat D: 51cm / 20in

Packaging dimensions
H: 75cm / 30in, W: 70cm / 28in, D: 90cm / 35in

Weight
13kg / incl. packaging: 23kg

Gliders
Plastic gliders installed as standard. Felt gliders available upon request

Colli quantity
1

Certifications



FSC® Mix 70%

Impact

- Made using FSC® certified wood, supporting responsible management of the world's forests.
- Uses water-based lacquer, safer for indoor air quality.
- Upholstered in Kvadrat Hallingdal that is EU Ecolabel compliant and Greenguard Gold certified.

Manufacturer

Produced in Poland by Trioline

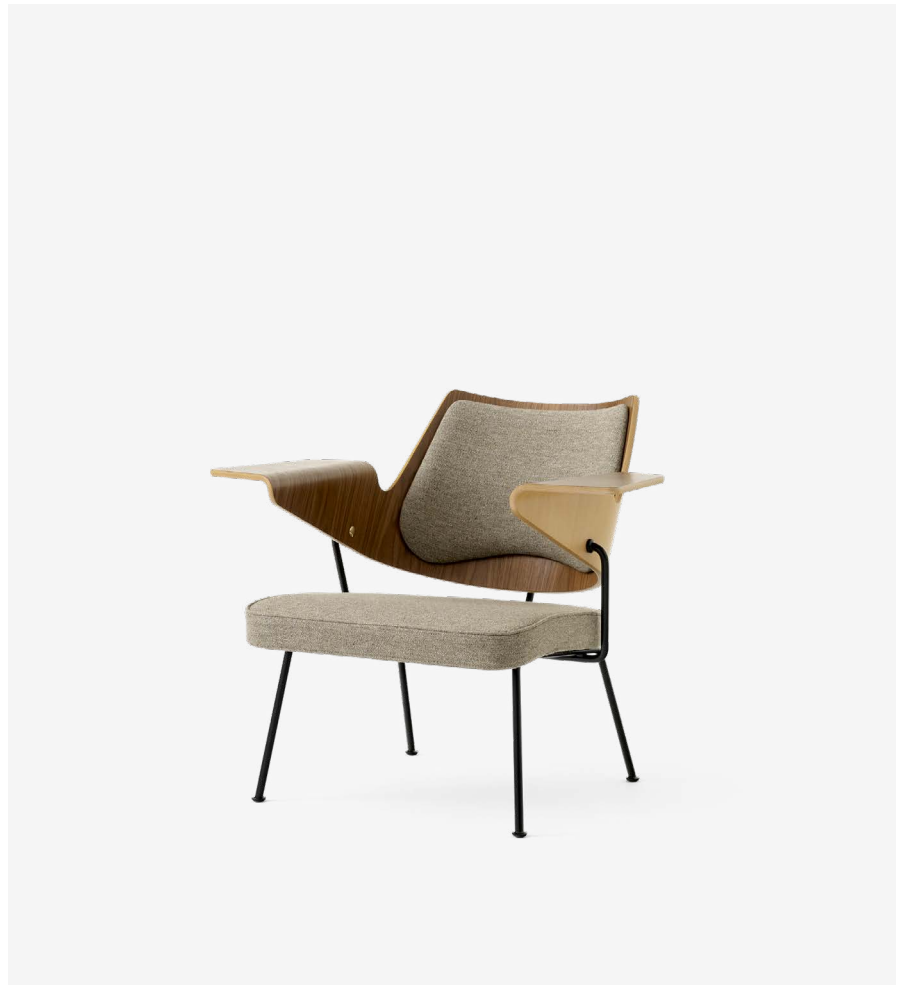

→ Black & Hallingdal 103



→ Black & Hallingdal 227

COM - Material consumption

Fabric usage: 1.29m based on a 140cm roll
Leather usage: 2.7 m²

Cleaning instructions

Please download our Material Care & Cleaning instructions through www.andtradition.com

→ Stock items

Black/Hallingdal 103, Black/Hallingdal 227

&Tradition®



H: 69cm / 27in
Seat H: 36cm / 14in
Armrest H: 38cm / 15in

W: 86cm / 34in, D: 66cm / 26in
Seat D: 51cm / 20in

Recycling & Disassembly

RFH Lounge Chair ^{RD8}

RECYCLING

The RFH Lounge Chair is built to last and we hope that it will serve you for many years to come. The chair is made from solid wood and wood veneer and can be easily disconnected from its base. All metal and wooden parts can be separated and delivered to a suitable recycling station.

SPARE PARTS

To purchase spare parts, please write to our sales support team at info@andtradition.com with your query.

5 YEAR WARRANTY

&Tradition provides a 5-year warranty with every RFH Lounge Chair. This warranty covers any faults present at the time of purchase, or those that may have occurred as a result of a manufacturing defect. The warranty is valid from the date stated on the original invoice.

DISASSEMBLY

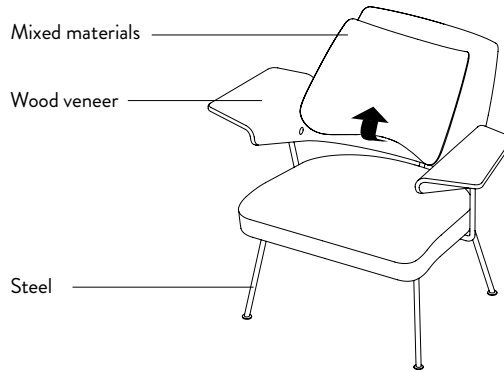

1. Remove the upholstery pad by pulling the bottom edge away from the backrest with two hands. The upholstery pad should come loose from the three hooks in the top and the two connectors at the bottom.

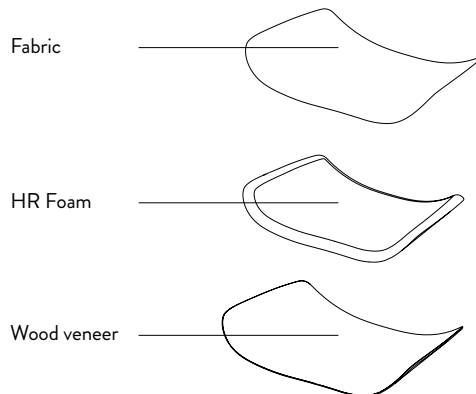

2. To disassemble the upholstery pad remove the nails on the backside that secure the fabric to the wood with a flat-headed screwdriver. The foam can be removed by gently pulling.

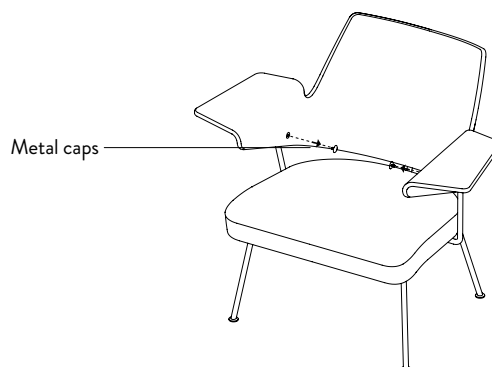

3. Unscrew the brass caps on the armrests to access the screws.

Recycling & Disassembly

RFH Lounge Chair ^{RD8}

DISASSEMBLY

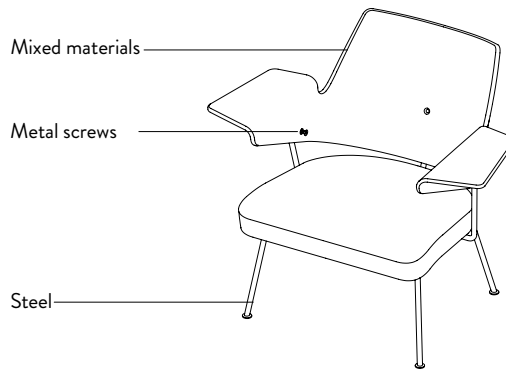

4. Remove x3 screws with an Allen key to loosen the backrest.

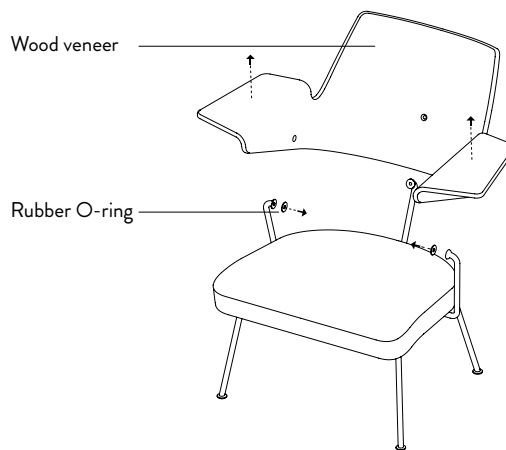

5. After removing the backrest from the base, the x3 rubber O-rings can be removed.

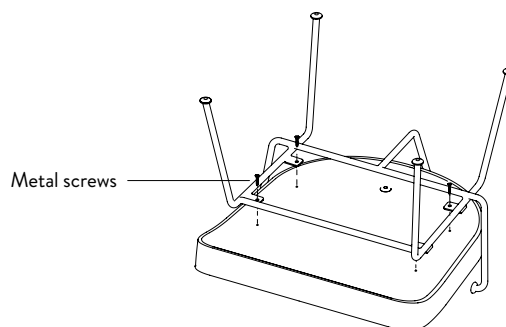

6. Remove the screws from the base of the chair to separate the seat plate from the frame.