

Branch-1 Display Unit

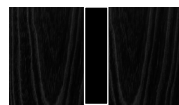

Blonde Uprights/
White Brackets/
Blonde Shelves



Black Uprights/
Black Brackets/
Black Shelves



Black Uprights/
Black Brackets/
Blonde Shelves

The Branch Modular Organization System blends mid-century style with modular components to give you an infinite number of elegant, open-storage options for home, office, or retail environments. This award-winning design features varying configurations that can be transformed into a wide range of organization or display units. Add-ons let you customize the size, layout and function of the system to suit your space. Refined details, such as rounded edges on the shelves and uprights, soften Branch, aesthetic and enhance its architectural style. Straightforward installation means you can spend more time perfecting your vision and display.

Design Trade Professionals: We aim to keep our designs in stock and ready to ship quickly for projects on a tight timeline. Designs may be customized with COM and alternate finishes (minimum quantities may apply). Visit guscontract.com for more information about our Trade & Contract programs.

Branch-1 Display Unit

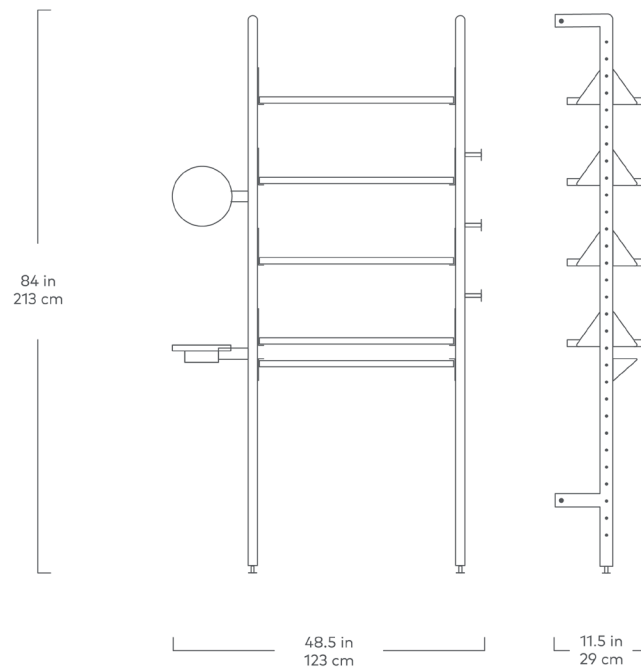

- Winner of the 2020 Architectural Digest Cleverest Award for functional, innovative product design.
- Comprised of: 2 Branch Uprights, 2 Slatted Shelves, 1 Shelf, 1 Hook Rail, 1 Side Mirror, 1 Side Tray and a set of 3 Single Hooks.
- Additional Add-Ons may be purchased to customize the configuration.
- Solid ash Uprights, Slatted Shelves, Hook Rail and Side Tray are all 100% FSC®-Certified in support of responsible forest management (FSC® 092551).
- Solid wood bullnose edge detail on Shelf.
- Side Mirror is 10" in diameter.
- Side Tray features a CNC-routed recess detail.
- Powder-coated steel accents.
- Shelves and Add-ons are height-adjustable.
- Actual depth of Shelf is 11".
- Actual depth of Slatted Shelf is 12".
- Components can be adjusted vertically in 2.5" increments.
- Max. weight per shelf/hook rail is 50lbs. Max weight per side tray and single hook is 10 lbs. Max weight per bay is 250lbs.
- Suitable for residential, office or retail spaces.
- Assembly required. All hardware and instructions provided.
- CARB Phase II, ANSI-BIFMA, and TSCA Title VI Compliant.
- Wood is a natural material, with variations in grain pattern and colour that make each design unique.

