

# **ARRAY**

**ASSEMBLY INSTRUCTION**

**W0UD**

ARRAY IS INSPIRED BY THE WOODEN SLATE CLADDING FOUND IN MODERN ARCHITECTURE. WITH ITS GEOMETRIC SHAPE AND HORIZONTAL SLATES, ARRAY CREATES A STRONG VISUAL DEPTH EFFECT FROM CATCHING BOTH LIGHT AND SHADOW. THE ILLUSION OF TRANSPARENCY IS INTENDED TO CREATE A FEELING OF GROWING CURIOSITY AS YOU GET A GLIMPSE OF WHAT IS HIDDEN BEHIND THE CLOSED DOORS. THE SLEEK LEGS LIFT THE SIDEBOARD FROM THE GROUND CREATING AN ELEGANT CONTRAST BETWEEN THE SOLID WOODEN CABINET ON TOP AND THE THIN METAL CONSTRUCTION UNDERNEATH. THE ARRAY SERIES IS GRAPHICAL AND MODERN IN ITS EXPRESSION WITH A MYSTERIOUS SHELL TO CONTAIN YOUR PERSONAL ITEMS.

Kasper & Nikolaj  
SAYS WHO

# **ASSEMBLY INSTRUCTION**

**PLEASE GO THROUGH THE FOLLOWING  
STEPS CAREFULLY. RETAIN THIS MANUAL  
FOR FUTURE REFERENCE TO ENSURE THAT  
YOUR NEW ITEM IS CORRECTLY ASSEMBLED  
IN CASE IT SHOULD BE DISASSEMBLED OR  
MOVED. WE ARE NOT RESPONSIBLE FOR  
ANY FAULTS OR DAMAGES CAUSED BY  
NOT FOLLOWING THESE INSTRUCTIONS  
CORRECTLY.**

**THIS INSTRUCTIONS MANUAL IS VALID FOR:**

**ARRAY SIDEBOARD (120 CM)**

**ARRAY SIDEBOARD (180 CM)**

**ARRAY HIGHBOARD (80 CM)**

**A X 1**

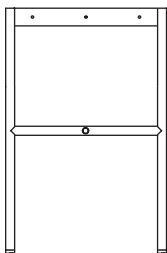
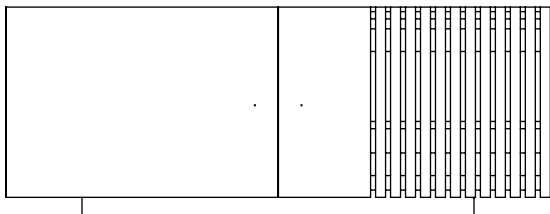

**B X 2**



**C X 1**



**D X 6**

**E X 2**



**F X 1**



**G X 1**



**H X 2**



**I X 2**

## TOOLS NEEDED

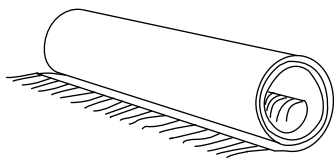

x 2



x 2

# STEP 1

MOUNT THE LEGS ON THE METAL FRAME UNDER THE WOODEN CABINET

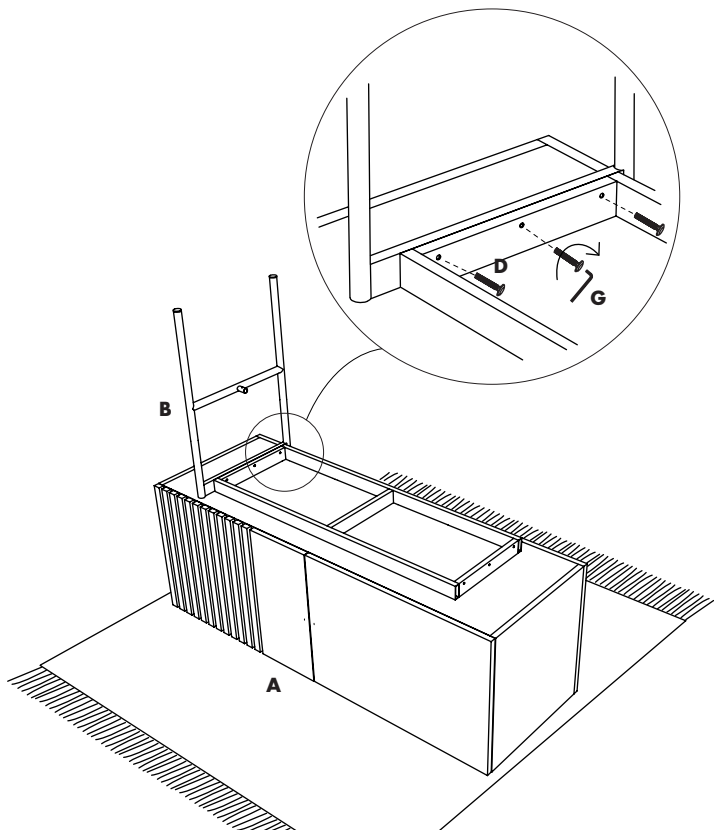

## STEP 2

MOUNT THE METAL CROSSBAR ONTO THE LEG

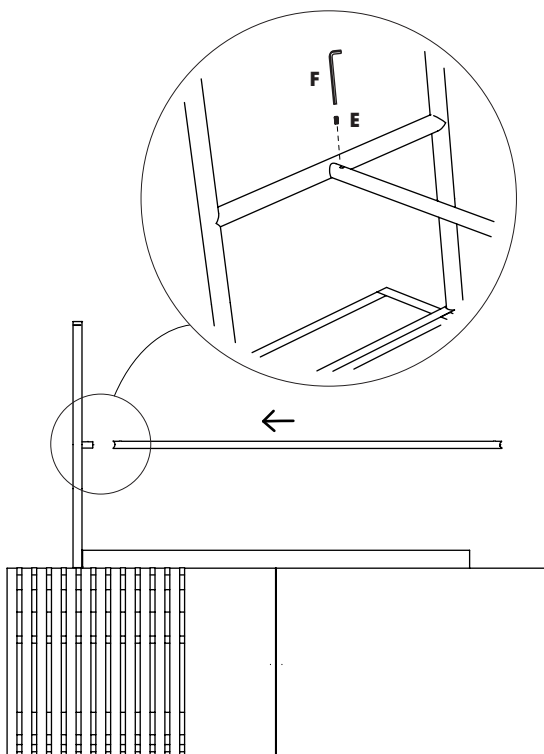



## STEP 3

MOUNT THE SECOND LEG ON THE METAL FRAME AND CROSSBAR

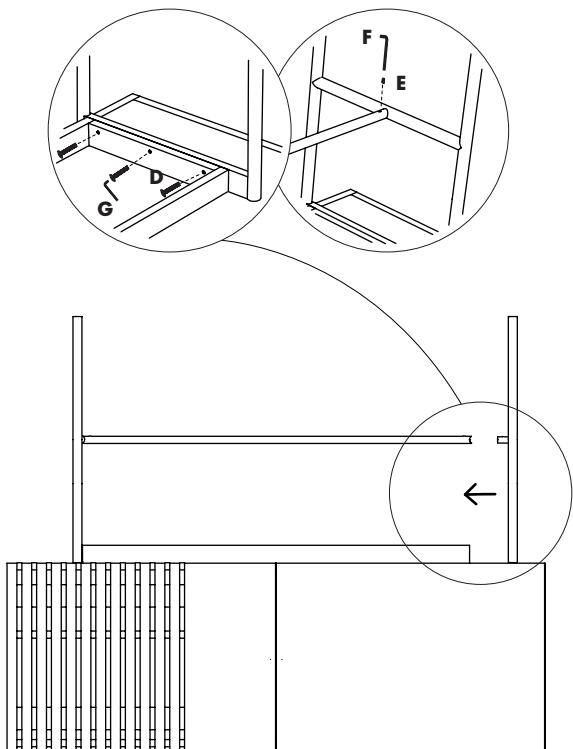

## STEP 4

DETACH THE HANDLES FROM THE INSIDE OF THE CABINET  
AND ATTACH THEM ON THE OUTSIDE OF THE WOODEN DOORS

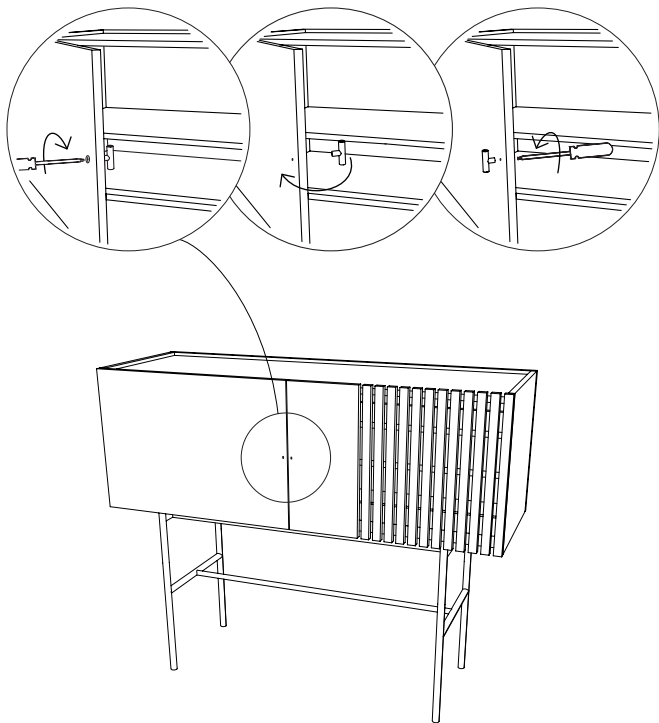

## STEP 5

ADJUST THE FEET TO LEVEL THE CABINET

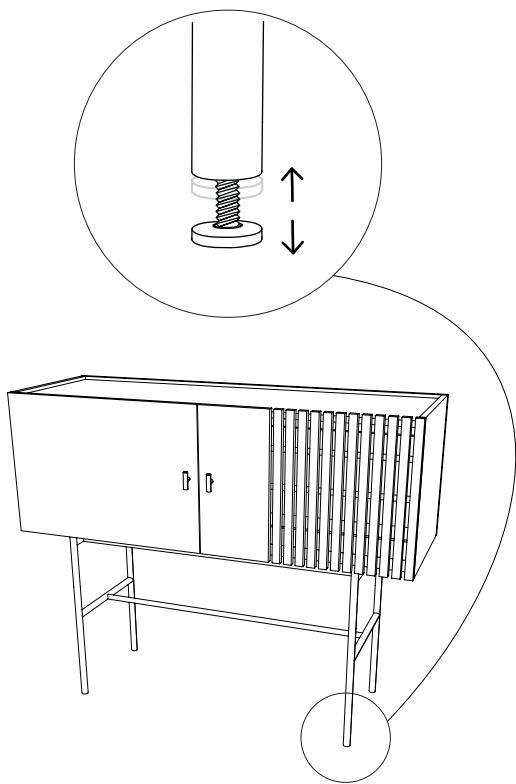

# ADJUSTMENT INSTRUCTIONS

SHOULD YOU NEED TO LEVEL THE DOORS,  
PLEASE FOLLOW THESE INSTRUCTIONS.

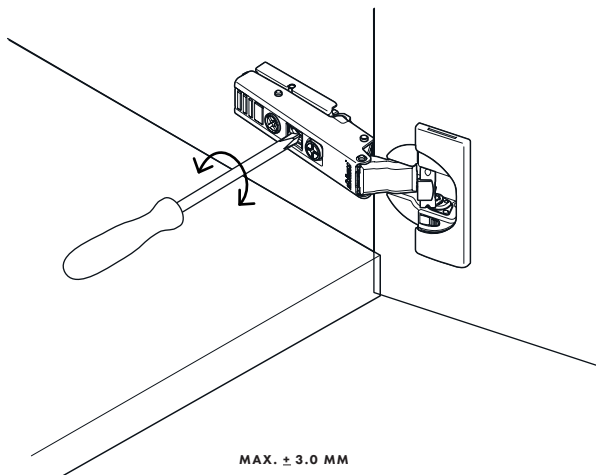
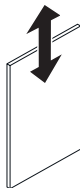

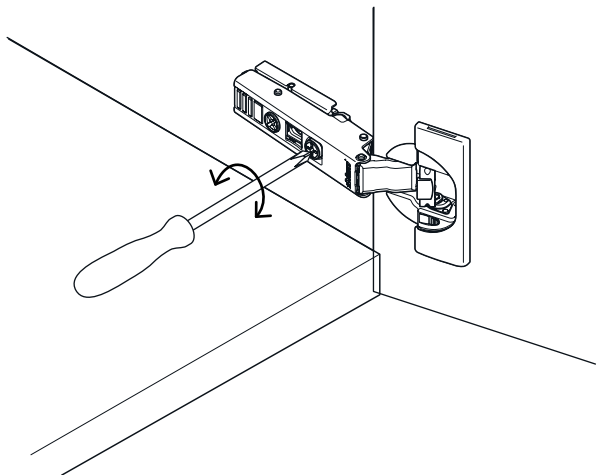

$\pm 2.0 \text{ MM}$

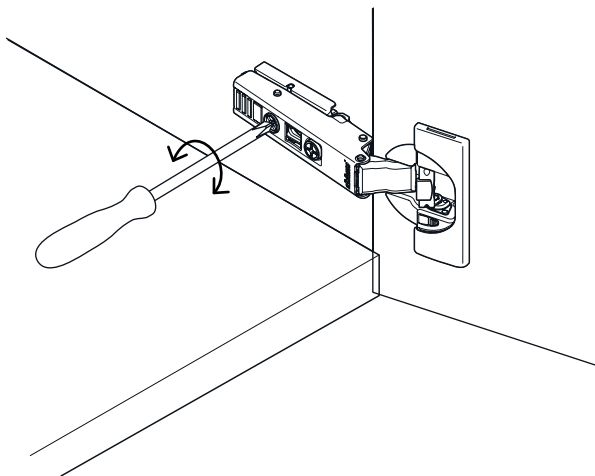

+ 3.0 / - 2.0 MM

# SAFETY INSTRUCTIONS

TO PREVENT THIS FURNITURE FROM TIPPING OVER  
RESULTING IN SERIOUS OR FATAL INJURIES, IT MUST  
BE PERMANENTLY FIXED TO THE WALL

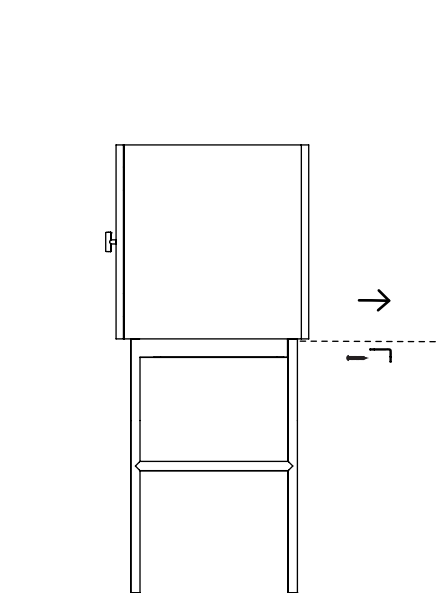

**MEASURE THE HEIGHT AND DRILL HOLES IN THE WALL. APPLY WALL PLUGS THAT ARE SUITABLE FOR YOUR WALL. MOUNT THE METAL BRACKET TO THE WALL WITH SUITABLE SCREWS AND THEN MOUNT THE BRACKET TO THE CABINET.**

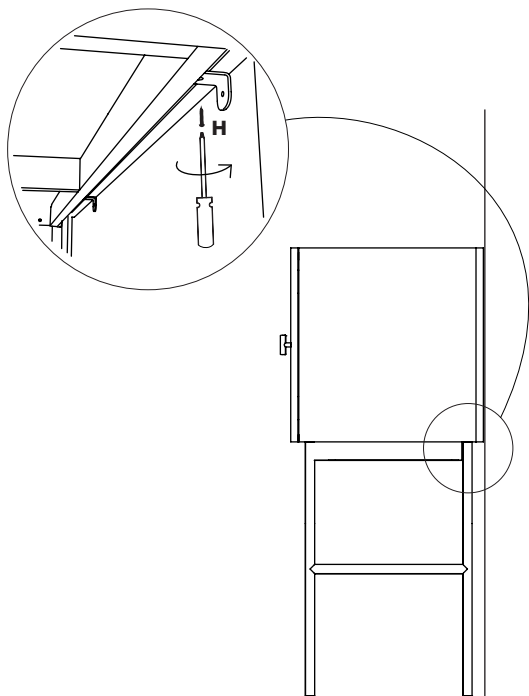



DESIGNED BY  
**SAYS WHO**

# GENERAL MAINTENANCE

## CARE INSTRUCTIONS

BECAUSE WOOD IS A LIVING MATERIAL, IT DEMANDS CARE AND MAINTENANCE THROUGHOUT ITS LIFE SPAN. DISCOLORATION OF WOOD CAN BE POSTPONED OR AVOIDED BY PROTECTING IT AGAINST SUNLIGHT, FLUCTUATING HUMIDITY, TOO MUCH LIQUIDS AND DIRT. WOOD USED FOR FURNITURE HAS A HUMIDITY LEVEL OF 7-8%, WHICH EQUALS TO APPROX. 40% RELATIVE AIR HUMIDITY. THIS IS WHY IT IS IMPORTANT TO KEEP WOODEN FURNITURE IN AN ENVIRONMENT WHERE THE HUMIDITY DOES NOT FLUCTUATE MORE THAN 40-60%. IN THE FIRST TWO MONTHS AFTER PURCHASE, WE RECOMMEND ALL SURFACES ARE LEFT EMPTY OF VASES, BOWLS AND OTHER ITEMS AS SUNLIGHT AND HUMIDITY CHANGES CAN CREATE DISCOLORATION IN THE MATERIAL AND IT MIGHT WARP. OTHER GENERAL RULES ARE TO USE A MOIST CLOTH FOR CLEANING AND REMOVE SPILT LIQUIDS ON THE SURFACE IMMEDIATELY AND GENERALLY AVOID PLACING HOT BEVERAGES ON THE FURNITURE.

WOOD HAS TO BE ABLE TO BREATHE OR ELSE IT WILL CRACK. WE RECOMMEND THAT YOU NEVER TO COVER YOUR WOODEN FURNITURE WITH MATERIAL THAT DOES NOT BREATHE, LIKE PLASTIC OR WAX FOR MORE THAN 12 HOURS AT A TIME. ALSO, REMEMBER NOT TO KEEP YOUR WOODEN FURNITURE IN A NON-HEATED ROOM AND PROTECT IT AGAINST TOO MUCH HEAT FROM A RADIATOR, A WOOD STOVE OR THE LIKE.

TAKE GOOD CARE OF YOUR WOODEN FURNITURE AS IT DOES NOT LIKE TOO MUCH DIRECT SUNLIGHT, TOO MUCH HUMIDITY FLUCTUATION, GETTING TOO WET, TOO MUCH COLD OR TOO MUCH HEAT.

OUR WOOD PRODUCTS ARE EITHER PAINTED, SOAP, OIL OR WAX TREATED OR HAVE A MATT LACQUER COATING. DIFFERENT MAINTENANCE PROCEDURES ARE NEEDED FOR EACH OF THESE TREATMENTS TO GET THE MOST OUT OF THE FURNITURE. BY THOROUGH PROCESSING AND TREATMENT OF THE MATERIALS USED, WE HAVE MADE SURE THAT IT IS EASY FOR YOU TO MAINTAIN THE QUALITY AND COLOUR OF YOUR FURNITURE BY FOLLOWING OUR DIFFERENT GUIDELINES.

WOUD

# **PAINTED SURFACES**

## **CARE INSTRUCTIONS**

### **DAILY CARE**

WIPE WITH A CLEAN CLOTH WRUNG IN WATER OR IN A SOLUTION OF WATER AND A NEUTRAL DETERGENT. REMOVE SOAP RESIDUE IMMEDIATELY USING A CLEAN, DRY CLOTH. AVOID USING SCOURING CREAM OR SCOURING PADS, AS THEY MAY SCRATCH THE SURFACE.

### **MAINTENANCE**

NO MAINTENANCE IS NEEDED AS SUCH, ONLY GOOD THOROUGH CLEANING. IF DAMAGE TO THE SURFACE OCCURS, IT MIGHT BE NECESSARY TO RE-PAINT THE SURFACE. WE RECOMMEND USING A PROFESSIONAL FOR THIS.