

# ADAM STOOL H65

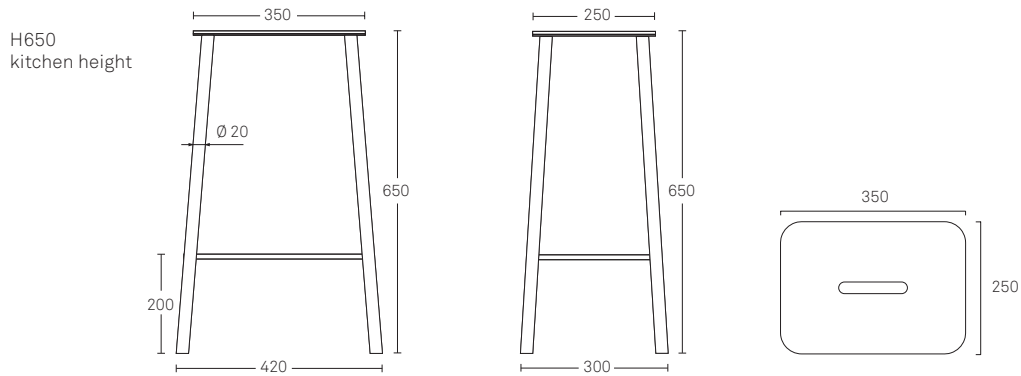

Design	Toke Lauridsen
Year	2010
Typology	Stool
Collection	Permanent Furniture
Origin	Lithuania / Poland
Material Tops	Natural oiled oak, natural leather, natural leather black
Material Rails	Powder coated steel

Product	Item No.	EAN code
Adam Stool Leather Matte White	6046	5712828026043
Adam Stool Leather Matte Black	6054	5712828096053
Adam Stool Oak Matte White	6049	5712828086047
Adam Stool Oak Grey	6060	5712828036066
Adam Stool Oak Matte Black	6062	5712828056064
Adam Stool Oak Natural leather Raw Steel	6081	5712828376087
Adam Stool Black Leather Matte Black	6074	5712823266079

ADAM

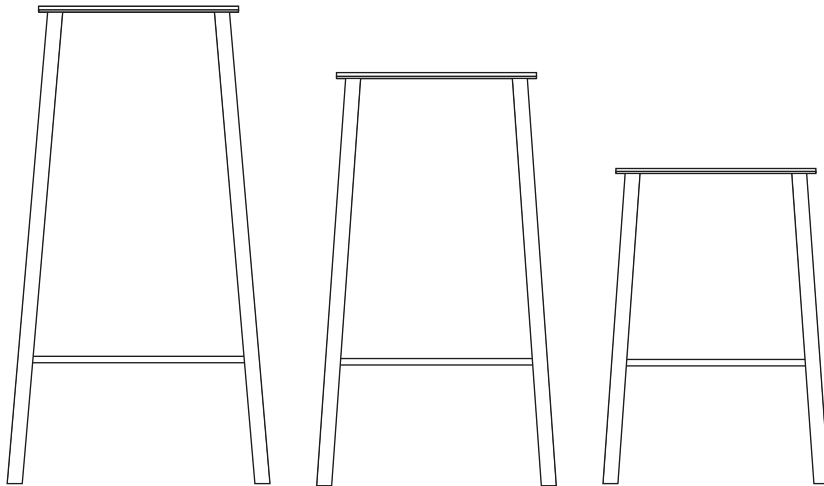

FRAMA

# CLEANING & MAINTENANCE OF OILED WOODEN FURNITURE

*Regular maintenance of oiled wooden furniture is both easy and efficient for long term use. Oak may have stripes and knots as these variations occur in nature. To achieve an optimal result we recommend oiling your product twice a year. We recommend a natural wood oil. All collection pieces are for indoor use.*

## **CLEANING:**

Daily cleaning is done with a soft cloth wrung out in clean water. Avoid using cleaners containing any type of chemicals on the furniture.

## **TREATMENT:**

1. Use a clean cloth dampened with warm water to clean.
2. Once the furniture is dry, apply oil to a clean soft cloth or sponge - do not pour the oil directly on the wood.
3. Rub the oil into the wood in the direction of the grain, treating the entire surface of the furniture piece.
4. Let the oil soak for about two hours, then remove any excess oil with a soft clean dry cloth.
5. Rub the surface with a clean soft cloth until a uniform surface is obtained, then let dry.

## **NOTE:**

End grain (edges), should be treated extra frequently to avoid dryness and cracking in the dry season (winter). Irregular distribution of moisture in the wood can cause unnecessary cracks and gap. To avoid this we recommend oiling both the top and underside of the furniture. To remove dust, salt and other deposits, rinse off with clean fresh water. Then use a clean, soft cloth to dry the piece.

Be aware that oily rags can ignite spontaneously. Rags and papers used in the oiling process will be flammable. Air dry after use.

# CLEANING & MAINTENANCE OF LEATHER FURNITURE

*Regular maintenance of natural leather furniture preserves value and ensures long term use. Unfinished natural leather has no protective clear coating and is highly absorbent which will create a darkened patina over time. Natural leather starts as a light tan/pink color and patinates to a dark umber hue. Please note new leather products will change color rapidly once in use. All collection pieces are for indoor use.*

## **CLEANING:**

Unfinished natural leather is more susceptible to stains and other damage because the leather has no protective clear coating and is highly absorbent. Wipe unfinished leather with a soft cloth or dry soft- brush only.

## **TREATMENT:**

If leather becomes highly stained and you must use a leather cleaner, clean the entire piece edge to edge. This process may darken the furniture a shade even after it's dry. One of the best aspects of unfinished natural leather furniture is that it will develop a patina over time. A patina is the nice amber or honey color the leather develops by absorbing oils from daily contact with your skin.

# MAINTENANCE OF METALS

*Some of the metals in the Frama collection are left untreated to allow for a natural patina to develop over time. See below to keep these beautiful signs of aging, or polish them away. All collection pieces are for indoor use.*

## CLEANING & POLISHING BRASS & COPPER:

**Brass:** Wash the brass with soapy water. To get rid of dirt or oil, mix a mild detergent with warm water. Dip a soft cloth into the soapy water, and wipe the piece down with the cloth. To polish brass, apply brass polish to a cloth, and rub it into the brass. Then use a clean, dry cloth while rubbing the brass to create shine.

**Copper:** Squeeze a lemon and sprinkle salt over the copper, and rub to remove any tarnishing. Rinse the copper, and dry with a soft, dry cloth.

## WAXING UNTREATED STEEL:

Since wax is only a coating and doesn't actually bind with steel, it must be periodically reapplied. As long as the piece is indoors, the wax will typically last at least a few years.

1. Use mineral spirits to clean the steel before application.
2. Using warm, clear wax, rub a thin layer over the steel with a soft cloth.
3. Using a clean cloth, buff out all of this dull wax with circular motions.
4. When the wax has been sufficiently buffed, the dullness will be gone, replaced with a slight shine. The finished wax should feel smooth and slippery to the touch.

## CLEANING POWDER COATED STEEL/ALUMINUM:

To clean powder coated furniture, carefully remove any loose deposits with a wet sponge. Use a soft brush (non abrasive) or cloth, and a mild household detergent solution to remove dust, salt and other deposits. Rinse off with clean fresh water. Then use a clean, soft cloth to dry the piece.

Dimensions : H 760-650-500 , W 350, D 250 mm.

Materials : Oak (natural oiled) or natural leather  
top, powder coated steel

Designed in Denmark  
Produced in Poland/Lithuania

# FRAMA

Org. St. Pauls Apotek - Fredericiagade 57 - Copenhagen - Denmark