

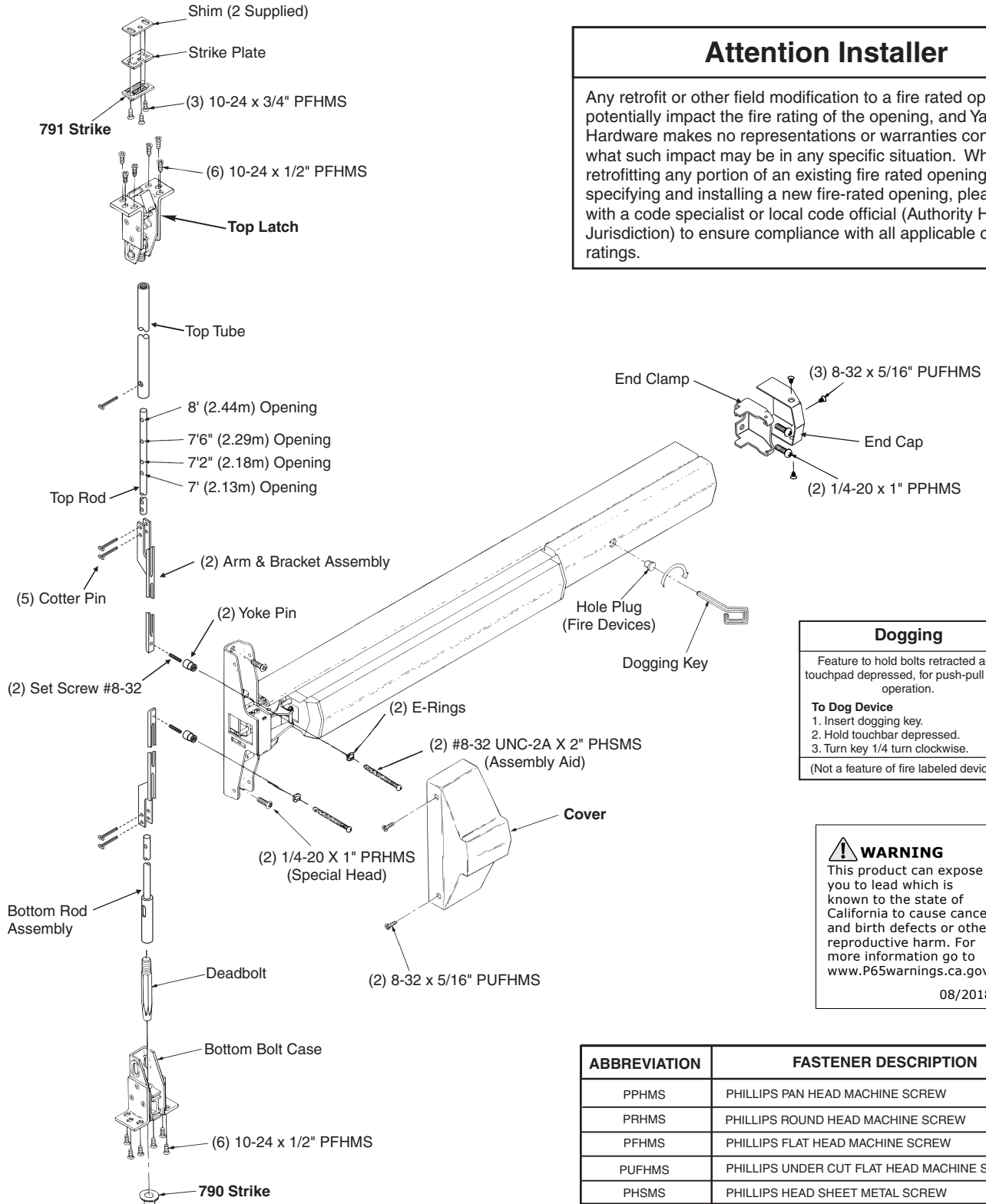

7120(F)Series Concealed Vertical Rod Exit Devices Installation Instructions

Attention Installer

Any retrofit or other field modification to a fire rated opening can potentially impact the fire rating of the opening, and Yale Locks & Hardware makes no representations or warranties concerning what such impact may be in any specific situation. When retrofitting any portion of an existing fire rated opening, or specifying and installing a new fire-rated opening, please consult with a code specialist or local code official (Authority Having Jurisdiction) to ensure compliance with all applicable codes and ratings.



Dogging

Feature to hold bolts retracted and touchpad depressed, for push-pull door operation.

To Dog Device

1. Insert dogging key.
2. Hold touchbar depressed.
3. Turn key 1/4 turn clockwise.

(Not a feature of fire labeled devices.)

WARNING

This product can expose you to lead which is known to the state of California to cause cancer and birth defects or other reproductive harm. For more information go to www.P65warnings.ca.gov.

08/2018

ABBREVIATION	FASTENER DESCRIPTION
PPHMS	PHILLIPS PAN HEAD MACHINE SCREW
PRHMS	PHILLIPS ROUND HEAD MACHINE SCREW
PFHMS	PHILLIPS FLAT HEAD MACHINE SCREW
PUFHMS	PHILLIPS UNDER CUT FLAT HEAD MACHINE SCREW
PHSMS	PHILLIPS HEAD SHEET METAL SCREW

All dimensions are in inches (mm) unless otherwise noted.



To Change Hand

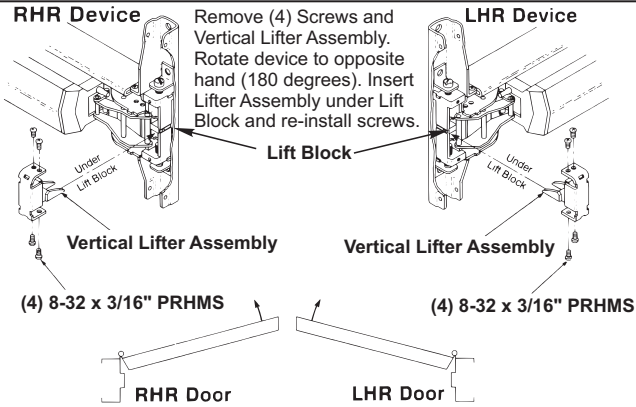

Maintenance

1. Periodically remove covers and coat mechanisms with a silicone base lubricant. This is particularly required in corrosive environments for proper product function.
2. Check mounting fasteners periodically. Retighten if found loose. Apply screw locking compound (available at automotive part stores) or change part fasteners if screws continue to back up.
3. Periodic checks (and adjustments) of strikes are required to compensate for changes in the opening (e.g. door sagging).

Check Before Starting

Unreinforced Doors or Frames

Doors and Frames with walls having a structural thickness (metal skin plus reinforcement or solid hardwood) to engage less than (3) full screw threads are considered unreinforced.

Unreinforced Doors: Use SNB (sex nuts and bolts) or Blind Rivet Nuts.

Unreinforced Frames: Use Blind Rivet Nuts.

Recommended fasteners for unreinforced openings are not necessarily supplied by Yale Locks & Hardware.

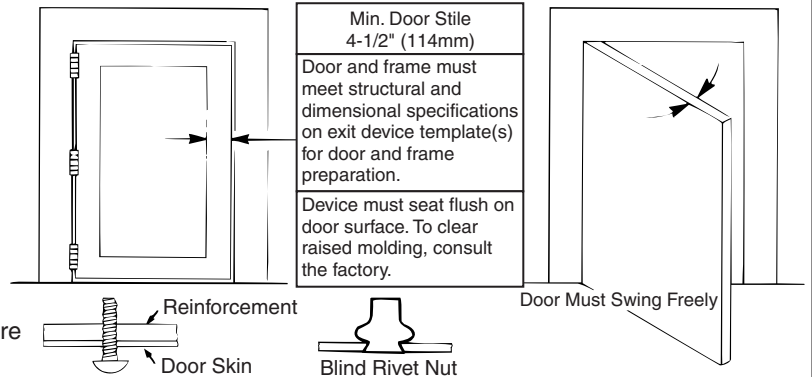

1. Mark Door

Locate and Mark Horizontal and Vertical Reference Centerlines as shown.

LHR door shown preparation is typical for both door hands.

Single Door or Pair without Mullion

Note: Bottom Bolt will retract to 1/8" (3mm) above Floor Strike. Floor covering in the door path must be laid out accordingly.

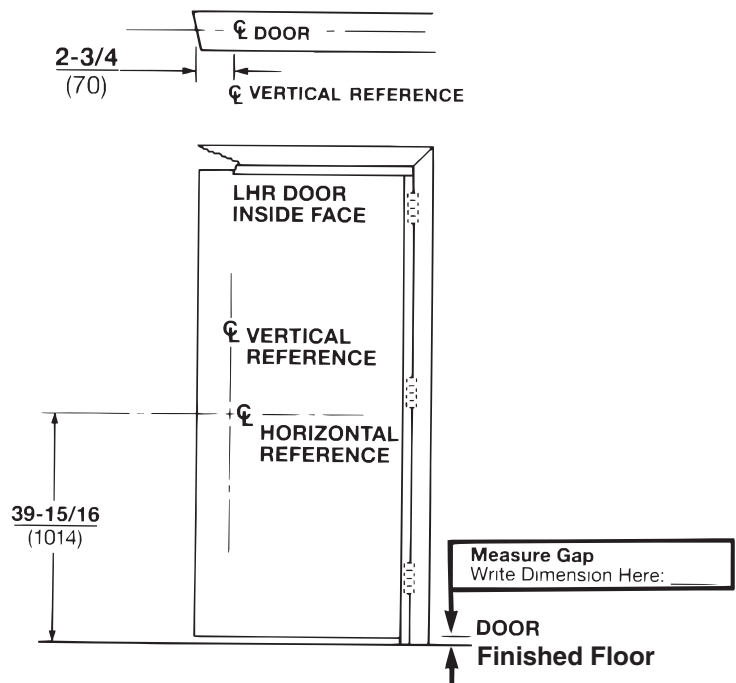

2. Prepare Door Frame & Sill

- A. Locate "Device Template" aligning VERTICAL REFERENCE and HORIZONTAL REFERENCE lines on door and template. Tape template to door face.
- B. Extend centerline of Rod and Strikes from "Device Template" to door top and bottom, on door face.
- C. Locate "Top Strike" and "Floor Strike" templates, aligned on centerline of Rods and Strikes on door. Tape templates in place. Note: An auxiliary door marker is included to verify correct door preparation. Reinforced doors and frames, with factory made cutouts, are recommended.
- D. Locate and tape Trim Template to door (See instructions packed with Trim).
- E. Spot and prepare holes:

Device Latch Assembly:

- Each (2) 1/4-20 Machine Screws*, or
- (2) 3/8 (10) dia. Sex Nuts & Bolts

(*) Metal reinforced door only.

Top Strike: (2) 10-32 machine screws;

Note: Third Screw MUST only be used to lock Strike in final position (Step 8C).

Bottom Strike: 5/8 (16) dia. X 3/4 (19) deep hole.

791 Top Strike Template
(Mounts on Frame Rabbet)

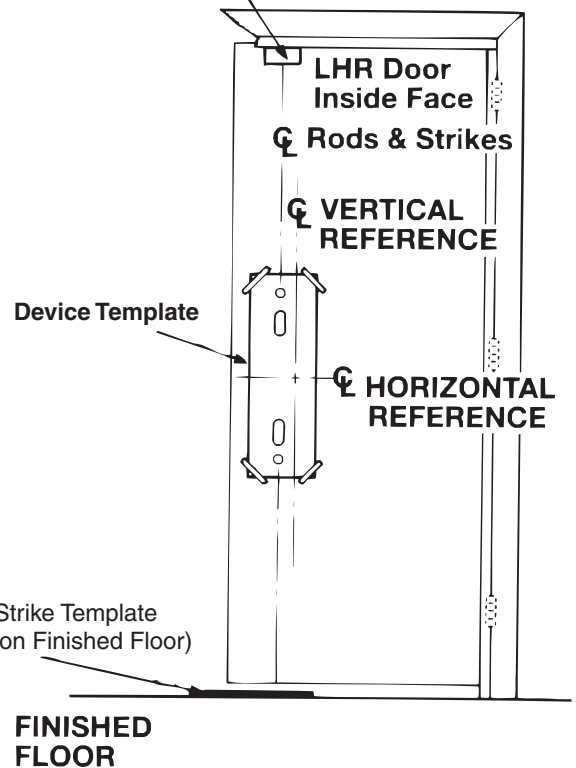

3. Size Device

Device must be field cut to size, unless standard opening and device are 36" (0.91m).

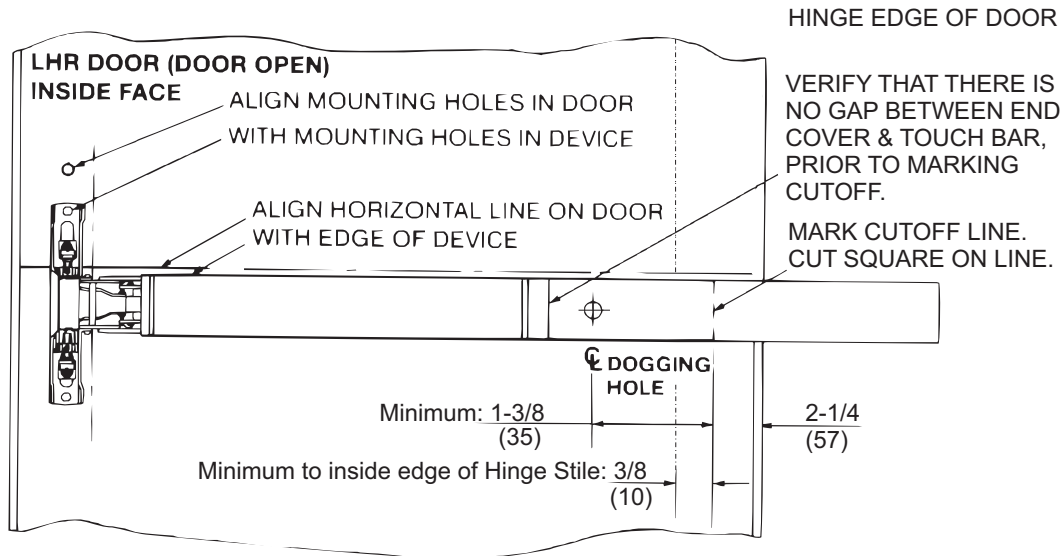

4. Rod Assembly and Preliminary Adjustment

- A. Remove door from opening. Set flat, device side up. (Do not hang door until Step 8 of device installation sheet)
- B. Set length of Top Rod Assembly (see Detail 1).
- C. Connect Top & Bottom Rods to Arm/Bracket Assemblies. (2 Cotter Pins each)
- D. Align Rod Setup Gauge over Device Cutouts and Centerlines. Tape Gauge to door face.
- E. Connect top latch to Rod Assembly.
- F. Set Top Latch and Rod Assembly in place on door. Maintain $1/8"$ (3) location from top as shown.
- G. Align Yoke Pin holes in Arm and Bracket Assembly with Alignment Hole in Rod Setup Gauge. Adjust top Latch and Rod Assembly for proper alignment. Latchbolt must be extended. (See Detail 2).
- H. Thread bottom bolt into Bottom Rod Assembly. Set Bottom Bolt Rod Assembly in place on door. Align Yoke pin hole in the Bottom Arm and Bracket Assembly with Alignment Hole in Rod Setup Gauge. Adjust Bottom Bolt until it protrudes $3/8"$ (10) + the gap from Step 1, past the bottom edge of door. Make sure Bottom Bolt is fully extended, (See Detail 3).

Detail 1 - Top Rod Assembly

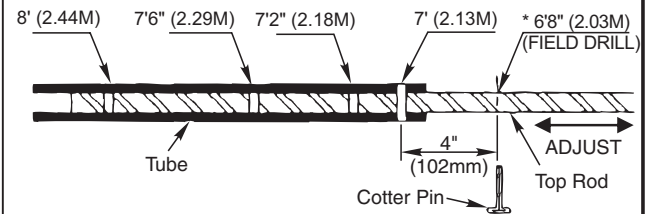

* For other door opening heights, locate and drill $1/8"$ (3) dia. hole in top rod (The top tube can be used as a drill guide for this operation).

Detail 2 - Top Latch

Detail 3

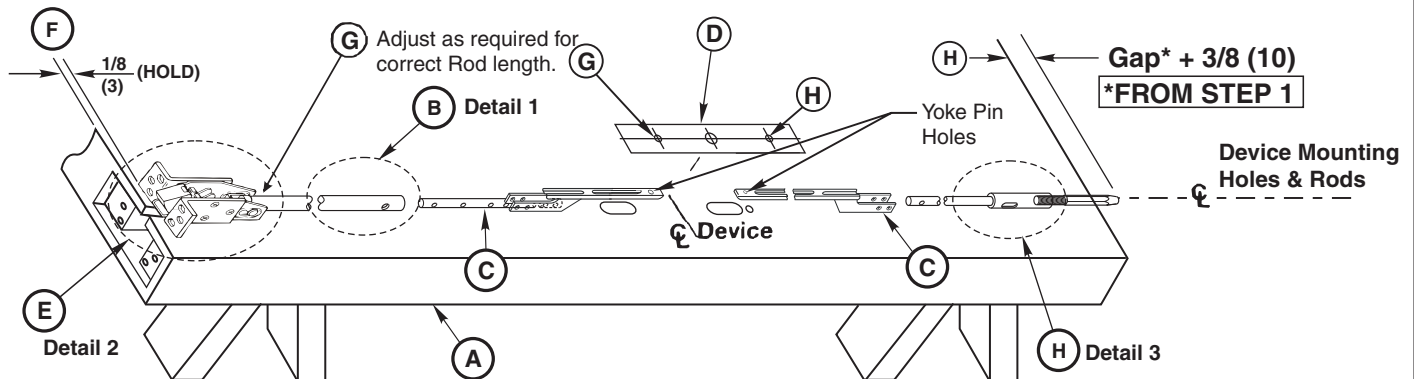
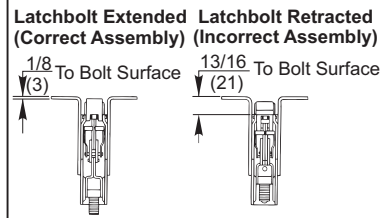

5. Install Rods

- A. Slide Rod Assemblies into door.
- B. Attach Top Latch and Bottom Bolt Case with (12) #10-24 X $1/2"$ PFMMS.
- C. Thread Set Screw into Yoke Pins (Insert With Hex Socket End Inside Pin). Thread #8-32 X 2" PHPMS Screws into slotted end of Yoke Pins, until seated to Hex Head Set Screw. (See Detail 1.)
- D. Install (2) Yoke Pin Assemblies into Arm and Bracket Assemblies.

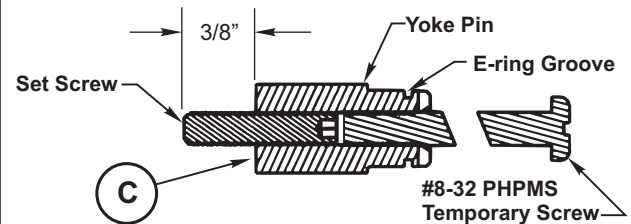

Detail 1 - Yoke Pin Assembly

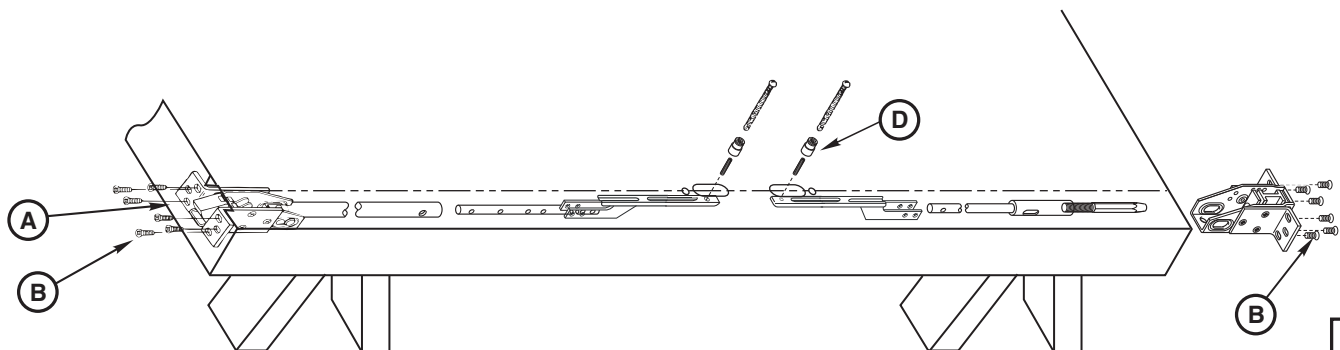

6. Install Device

- A. Mount trim when required per installation instruction sheet provided with trim pack.
- B. Seat device in place using the Temporary Screws from Step 5 to position the Yoke Pins to the latch head. Install E-Ring into Yoke Pin Grooves. (See Detail 1).
- C. Fasten device Latch Head (2) 1/4-20 PPHMS or 3/8" (10) dia. SNB.
- D. Remove Temporary Screws.
Note: be certain to tighten Yoke Pins after removal of Temporary Screws.
- E. Center end of device on horizontal reference line of door using the End Clamp as a template, locate the end clamp mounting holes.
- F. Prepare end clamp holes and mount End Clamp using (2) 1/4-20 PPHMS or 3/8" (10) SNB

Detail 1
(Typical 2 Places)

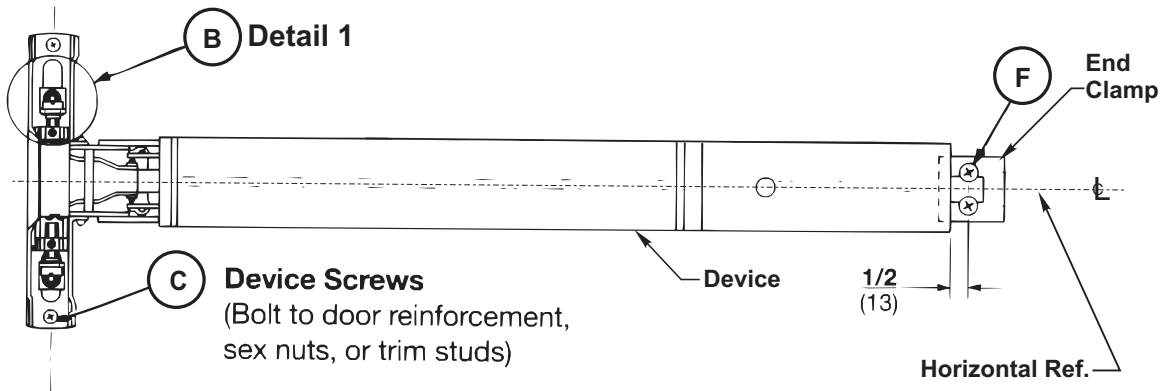
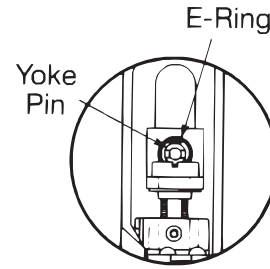

7. Install Strikes

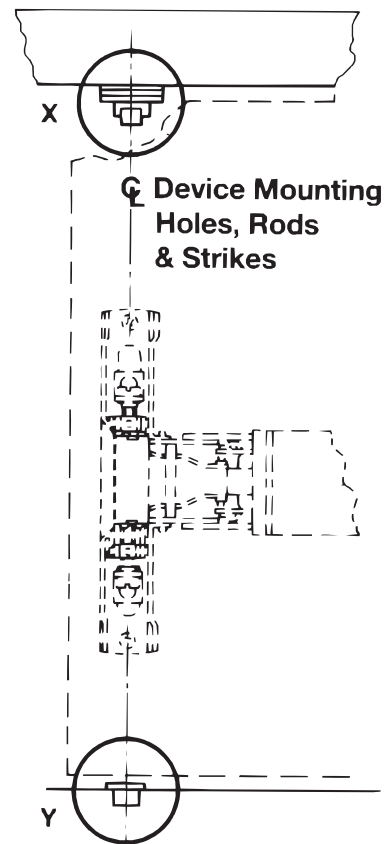
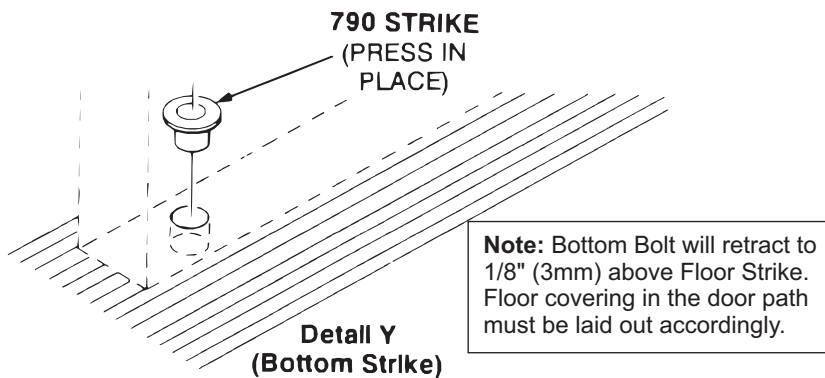
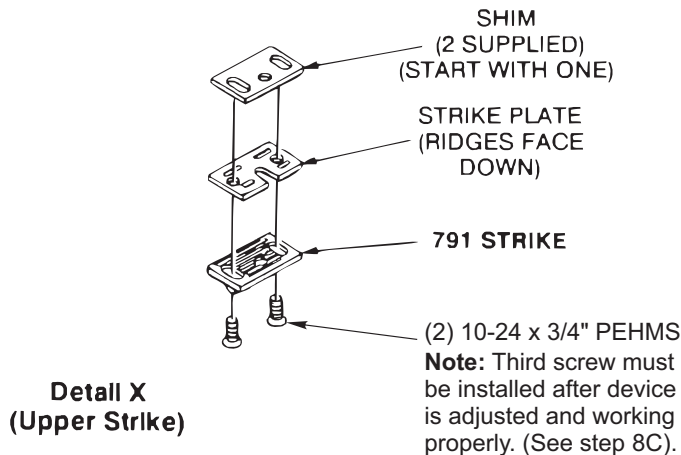

8. Complete Installation

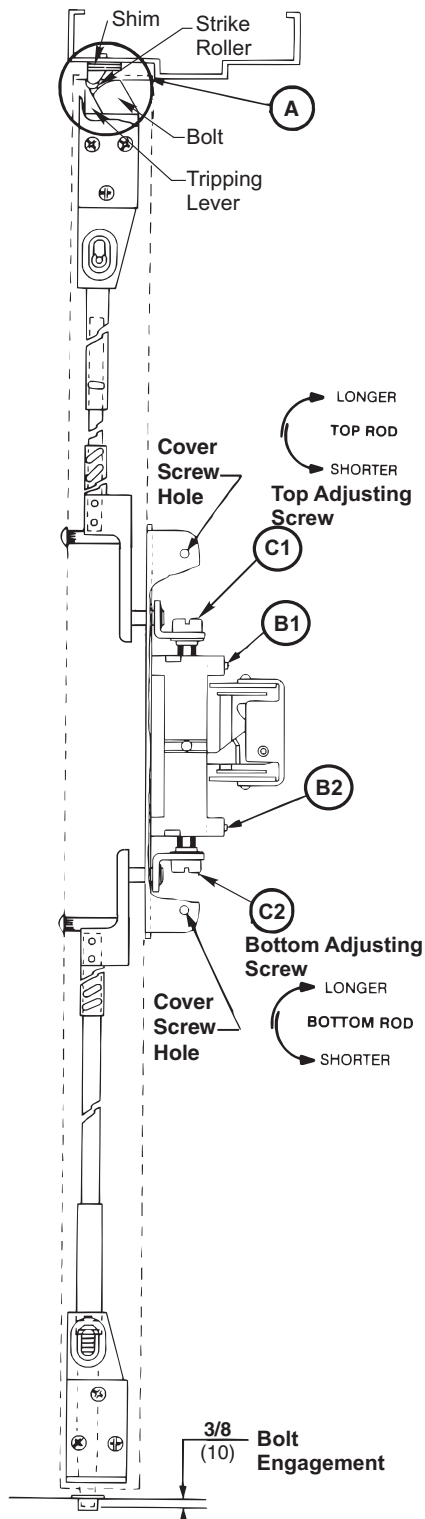

- A.** Rehang the door plumb and true to the opening. Set strike roller between tripping lever and bolt. **DO NOT PRELOAD THE BOLT.** Shim strike as needed.

NOTE: Rods should move freely inside door. Bolts extend automatically and should deadlock when door closes and top strike hits tripping lever. Top bolt should retract flat. Bottom bolt should travel 1/2" and engage 3/8" into strike in down position, without dragging on floor surface in up position.

Test device action by touchbar, by trim, and by dogging. Adjust as needed.

B. Rod Adjustment for Proper Bolt Throw

1. Use 3/32" hex wrench to loosen set screws B1 and B2.

2. Adjust the top rod first with adjusting screw C1. With device in dogged position (panic devices) or touchbar fully depressed (fire devices) adjust top rod so that the top latchbolt is flush and the hold back feature is engaged. Lengthen top rod an additional 1/2 turn for proper latchbolt positioning.

NOTE: If adjusting screws bottom out before proper device operation, door and device must be removed so larger adjustments may be made by threading rod in or out, or by moving cotter pin to different hole in rod (See Installation Instructions Step 4).

3. Adjust bottom rod with adjusting screw C2. With top latch retracted in hold back position, and touchbar dogged or fully depressed, adjust bottom rod so that the deadbolt clears the strike by 1/16". The bottom rod should be in position in the active case with the square head of the connector hanging in the Guide. (See note in Step 2 above).

4. Check device operation by opening and closing the door. An additional minor adjustment may be required for full retraction and correct strike engagement.

NOTE: To avoid thread damage and provide positive locking, be sure set screws engage flats on adjusting screws.

- C.** After acceptable device function, install third screw in top strike to lock strike in position with 10-24 x 3/4" PFHMS.

- D.** Install device cover and end cap with (2) 8-32 PFHMS each.

TAPE TO FRAME RABBET

791 STRIKE (Top Strike)

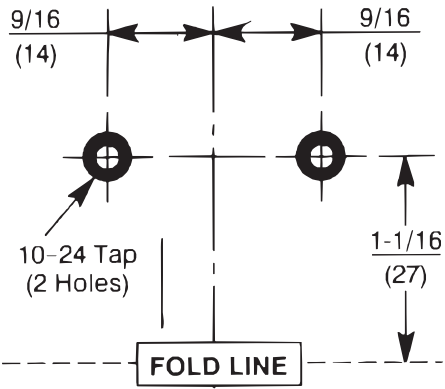

⊕ Rods & Strikes

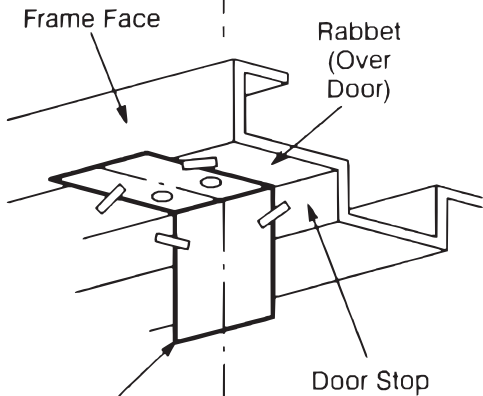

STRIKE MARKER
(Tape as Shown)

⊕ Device Mounting Holes, Rods & Strikes

CUT LINE

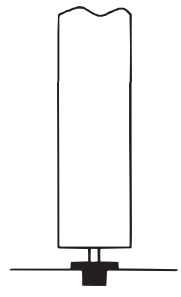

ALIGN WITH DOOR EDGE AND DOOR FACE (DEVICE SIDE)

LHR Door
(Over for RHR Door)

790 STRIKE (Floor Strike)

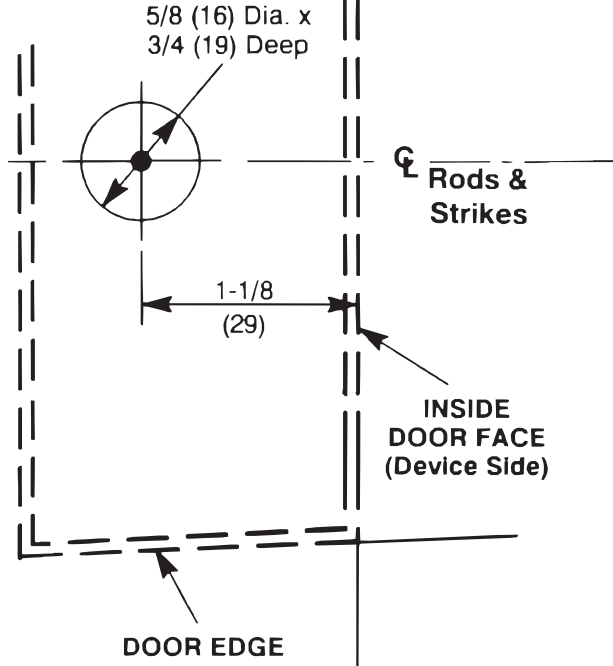

CAUTION:

Office copiers, printers and facsimile machines may change the size of a drawing and make the template inaccurate to use as a door marker.

Door Inside
Face Surface

*Rods and Strikes ϕ
Centerline.

DEVICE

LHR Door
(Over for RHR Door)

ϕ VERTICAL
REFERENCE

CAUTION:
Office copiers, printers and
facsimile machines may
change the size of a
drawing and make the
template inaccurate to use
as a door marker.

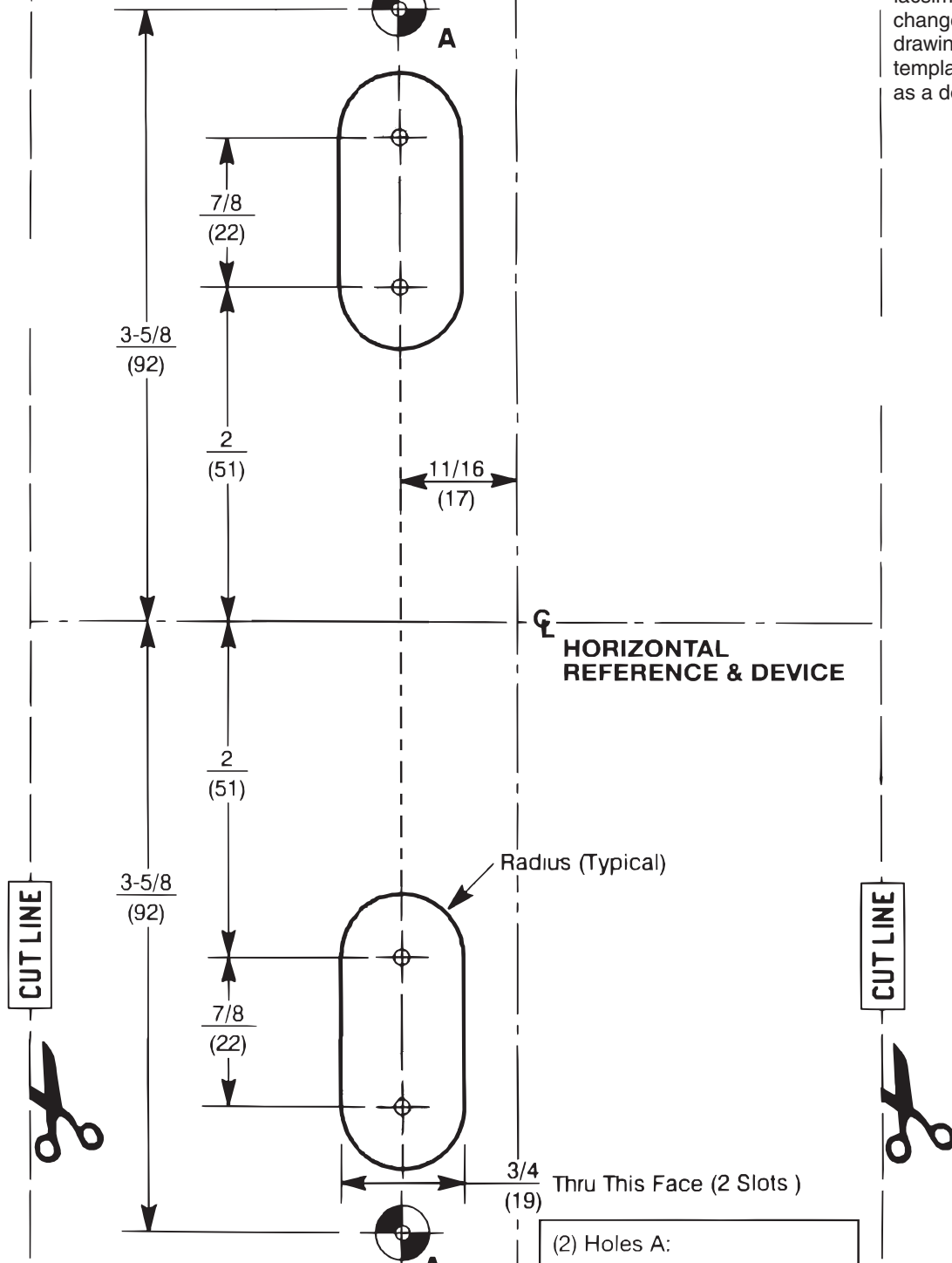

(*) Mark ϕ Rods on door face
Note that the centerline of the
rods and strikes, used to install
top and bottom bolts, is not the
Vertical Reference centerline.

(2) Holes A:
1/4-20 tap
(metal reinforced doors),
OR
 $\frac{3}{8}$ dia thru door for SNB
(9.50)
(all other doors).

Instructions:

1. Unreinforced frames (total wall thickness less than 1/8 (3.2) require) that 10-24 blind rivet nuts (by others) be used to bolt strike.
2. Dimensions given in inches (mm).
3. **CAUTION:** Office copiers, printers and facsimile machines may change the size of a drawing and make the template inaccurate to use as a door marker.

AUXILIARY DOOR MARKER (Top Strike Clearance Cutout Top & Bottom Latch Mounts)

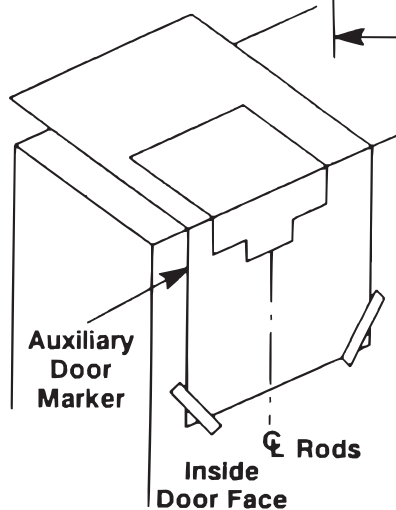
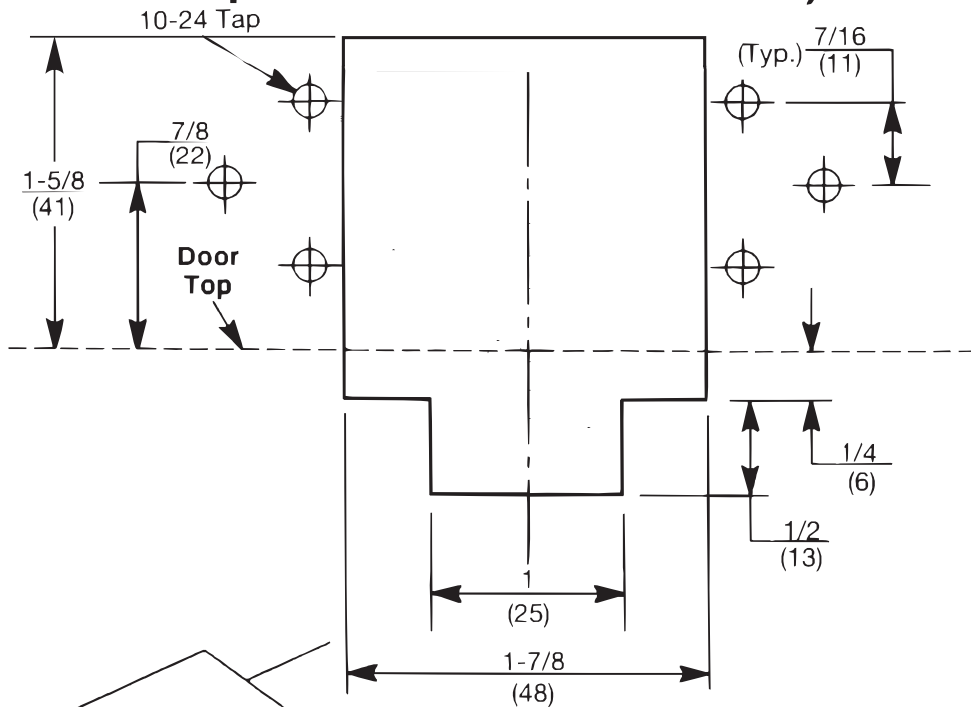

Rods

Notes:

- 1-1/2 (38) square clear vertical cavity, centered on door and rods, is needed.
- Top and bottom latch holes shown for reference. Position latch in place to locate holes.
- Fold marker and tape to door face to locate cutout.

RHR Door
(Over for LHR Door)

790 STRIKE (Floor Strike)

CAUTION:

Office copiers, printers and facsimile machines may change the size of a drawing and make the template inaccurate to use as a door marker.

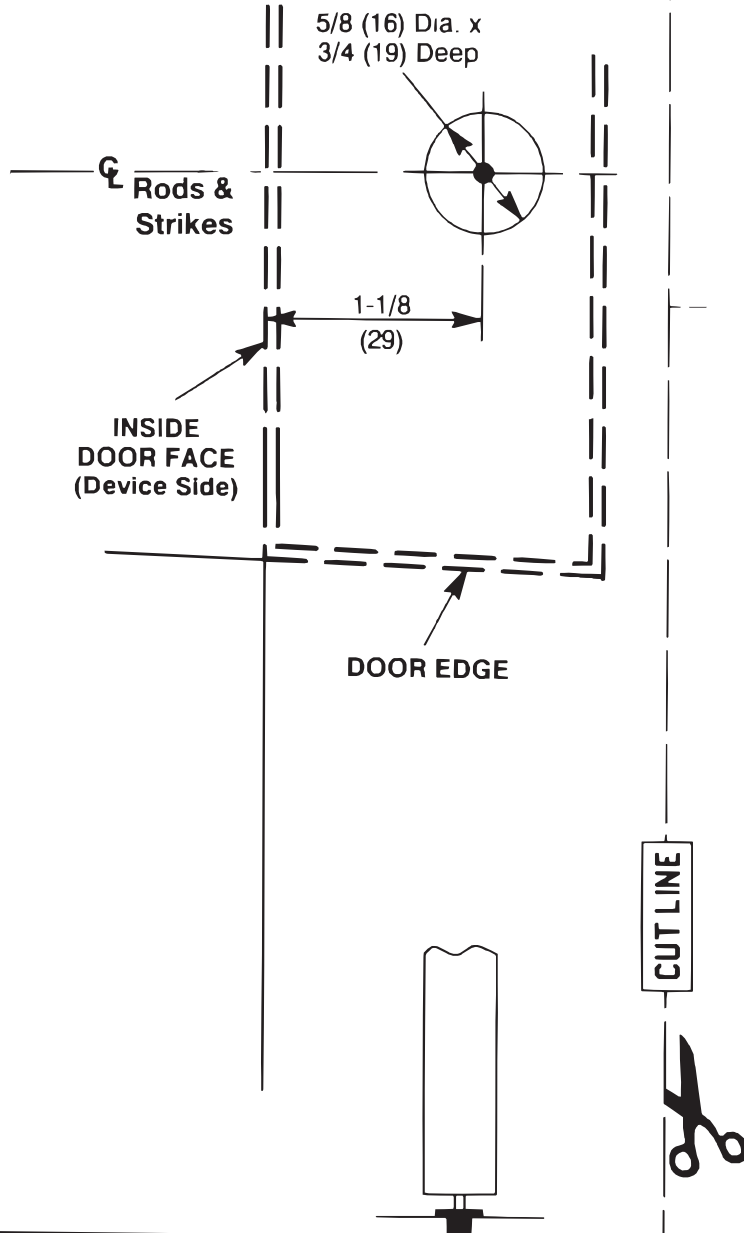

**ALIGN WITH DOOR
EDGE AND DOOR
FACE (DEVICE SIDE)**

**RHR Door
(Over for LHR Door)**

(2) Holes A:
 1/4-20 tap
 (metal reinforced doors),
 or
 3/8 dia thru door for SNB
 (9.50)
 (all other doors).

**Door Inside
Face Surface**

☉ *Rods and Strikes
Centerline.

DEVICE

CAUTION:
 Office copiers, printers
 and facsimile machines
 may change the size of
 a drawing and make
 the template inaccurate
 to use as a door
 marker.

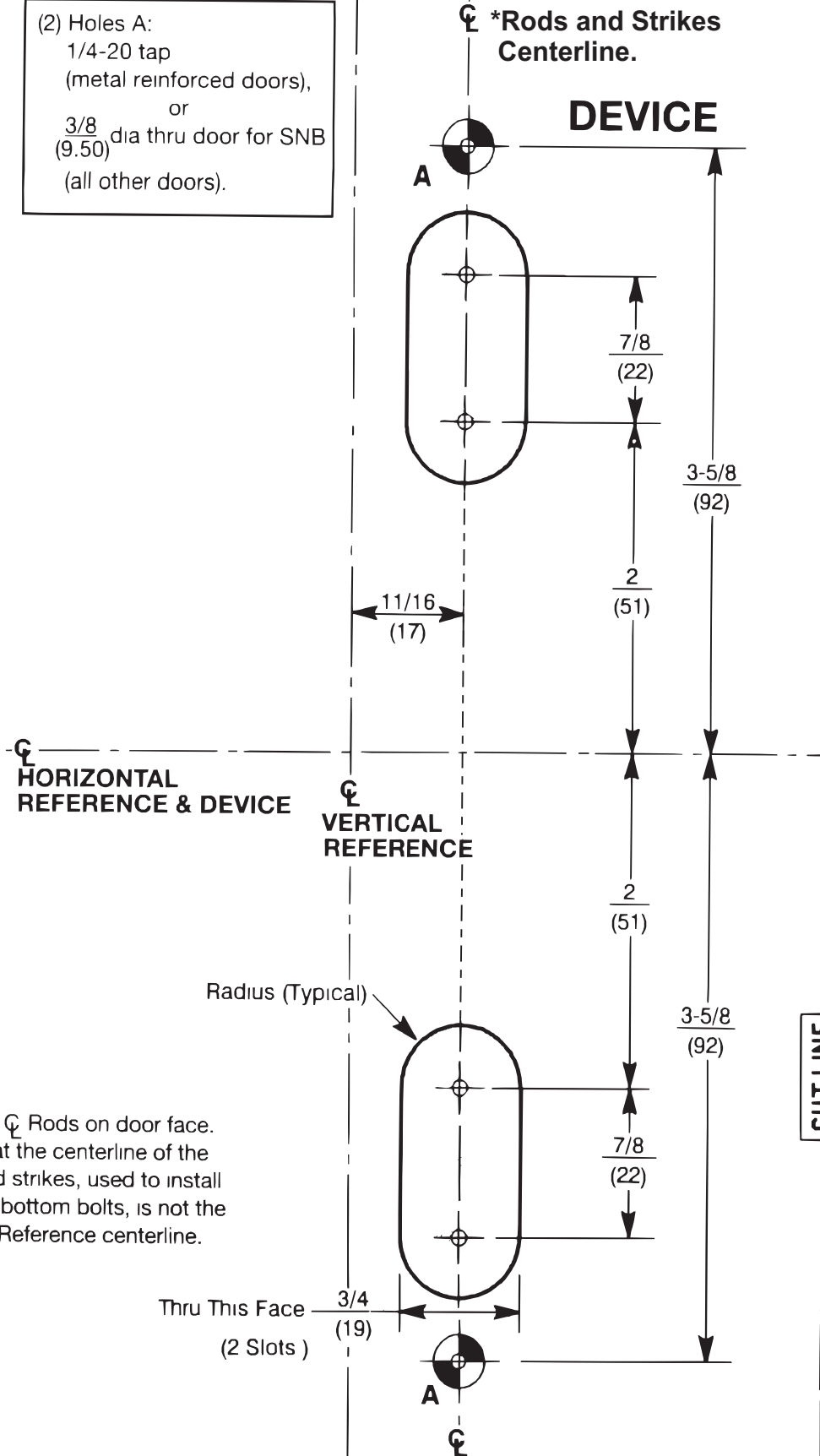

(*) Mark ☉ Rods on door face.
 Note that the centerline of the
 rods and strikes, used to install
 top and bottom bolts, is not the
 Vertical Reference centerline.

CUT LINE



Plastic Installation Template 7000 Exit Devices

For use in conjunction with instruction sheets packed with exit device.
Holes and slots are identified below by exit device series and trim. Prep door and frame for only those features required for the exit device being installed.

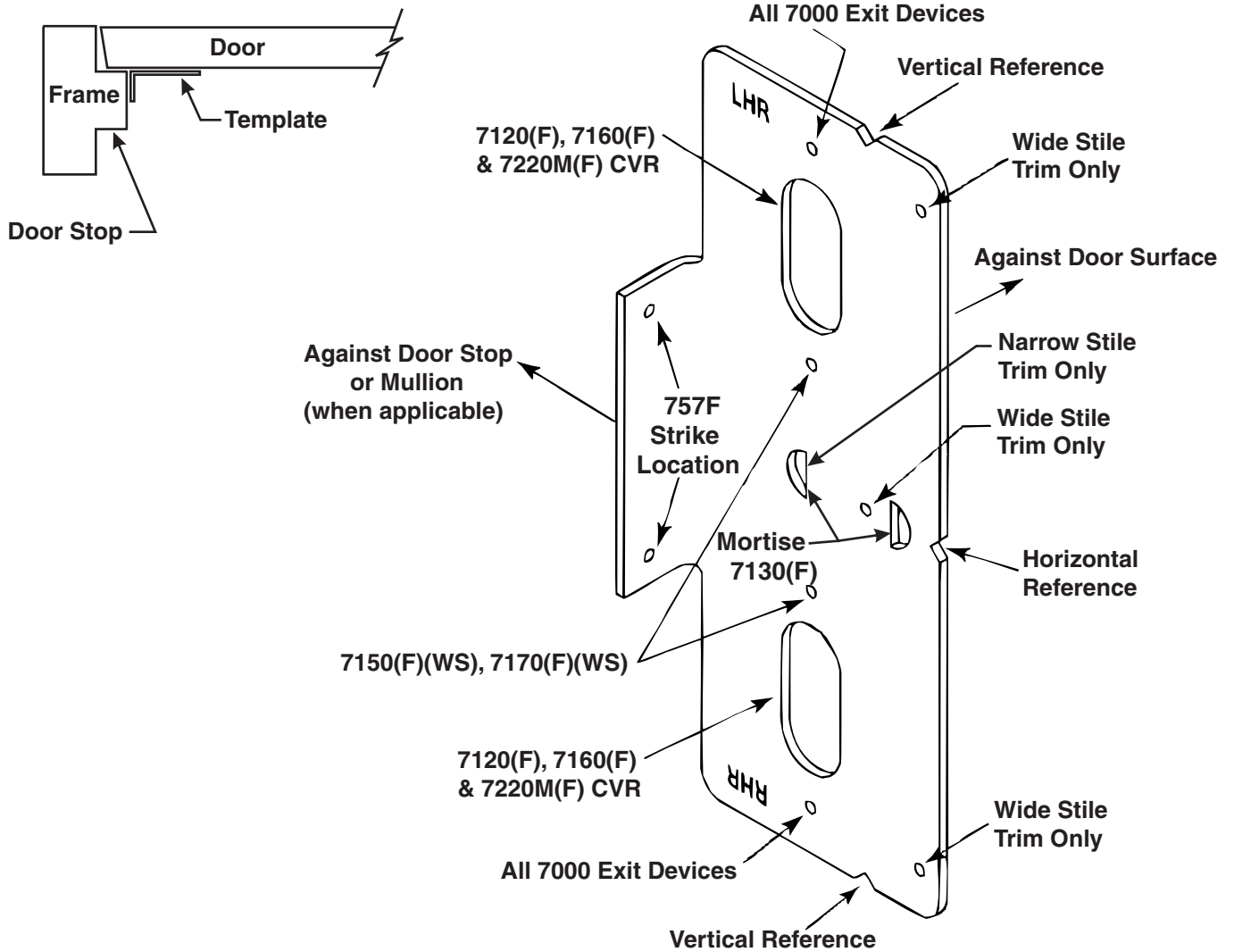

Yale Locks & Hardware

Product Support Tel 800.438.1951 • www.yalelocks.com

Yale Locks & Hardware is a division of Yale Security Inc., an ASSA ABLOY Group company.

Yale® is a registered trademark of Yale Security Inc., an ASSA ABLOY Group company. Other products' brand names may be trademarks or registered trademarks of their respective owners and are mentioned for reference purposes only. These materials are protected under U.S. copyright laws. All contents current at time of publication. Yale Security Inc. reserves the right to change availability of any item in this catalog, its design, construction, and/or its materials. Copyright © 2001, 2013, Yale Security Inc., an ASSA ABLOY Group company. All rights reserved. Reproduction in whole or in part without the express written permission of Yale Security Inc., an ASSA ABLOY Group company is prohibited.