

### Installation Instructions

1. Pull trim becomes handed after assembly (parts are universal). See other side for components and instructions.
2. After marking door inside face for device location (Device Instructions), carry "Centerline of Device Mounting Holes" from outside door face. Follow steps 2a and 2b, below.
  - 2a. MEASURE INSIDE LINE LOCATION.
  - 2b. CARRY DIMENSION OVER TO OUTSIDE FACE.
3. Carry horizontal "Centerline of Device" from inside to outside door face.
4. Align trim template and tape to door, outside face.
 

**CAUTION:** Office copiers and facsimile machines may change the size of a drawing and make the template inaccurate to use as a door marker. If this is not the original template packed with the trim, use only the dimensions written on the template to locate the holes on the door (do not use the template as a door marker).
5. Spot holes and prepare door for trim.
6. Mount trim to door. Fasten finger tight with 2 screws (packed with device). See Figure 2.
7. Cut trim tailpiece as shown in Figure 1.
8. Seat device so that trim tailpiece penetrates cam slot, as shown in Figure 2. Continue as shown in device instructions. Bottom pull post of 512F trim fastens to door, with oval head screw seated on countersunk washer (packed with trim).

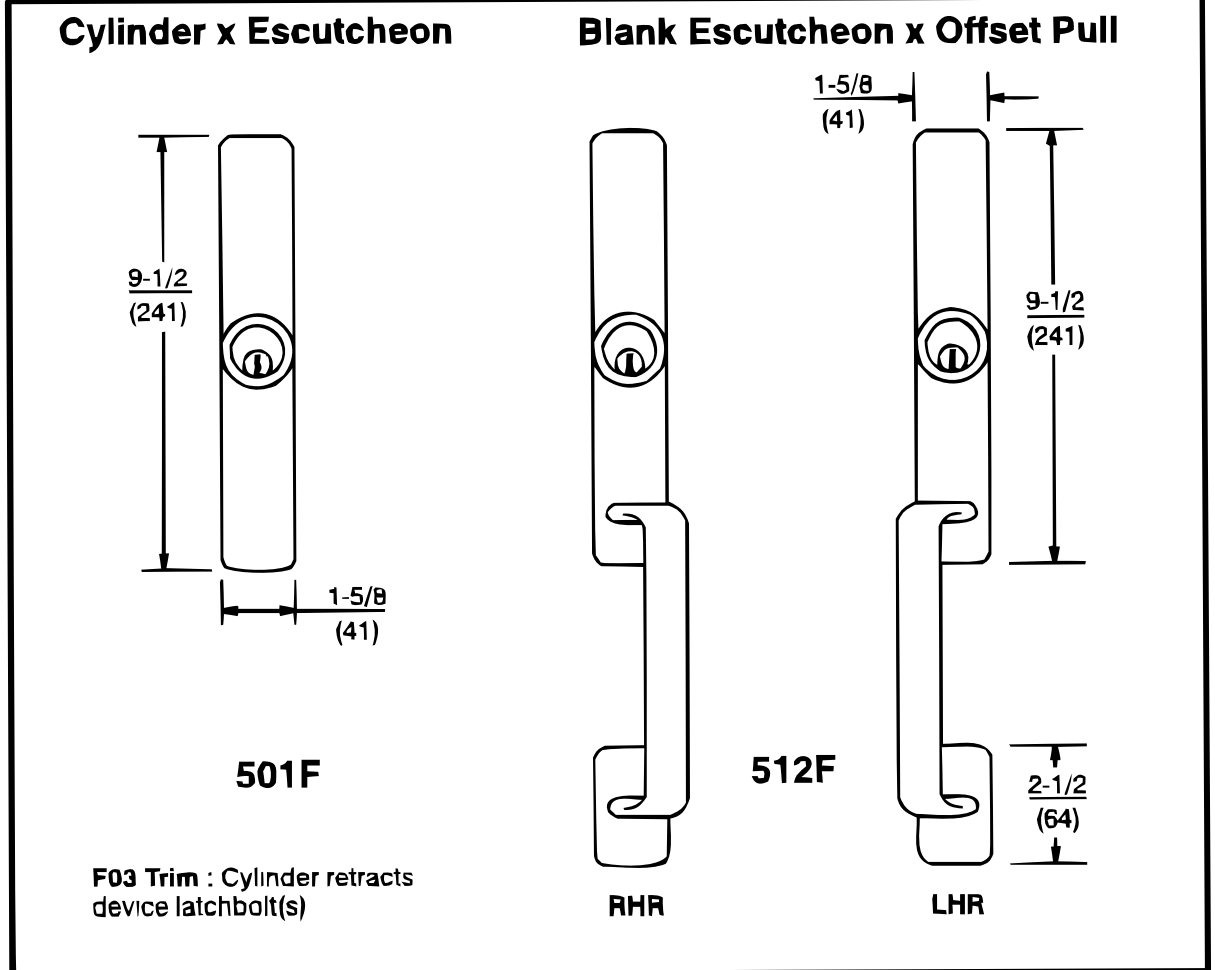
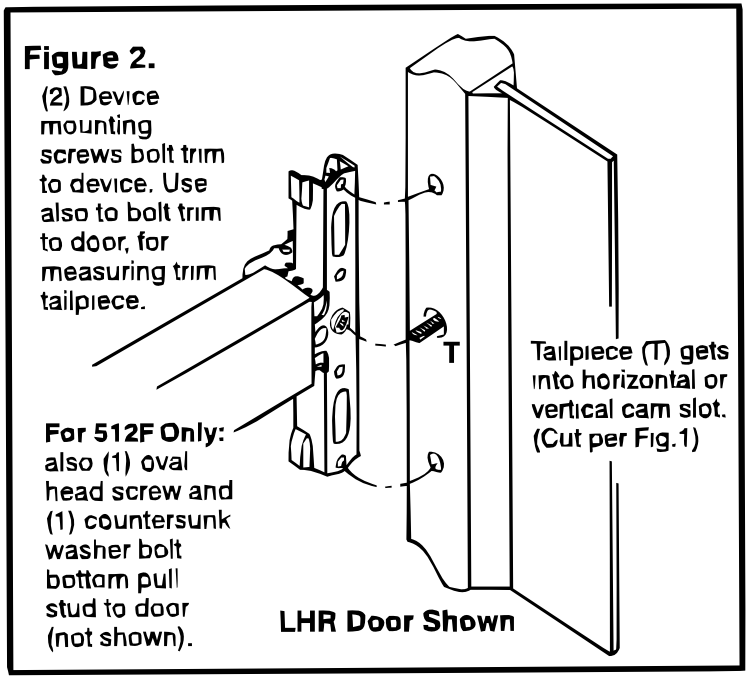
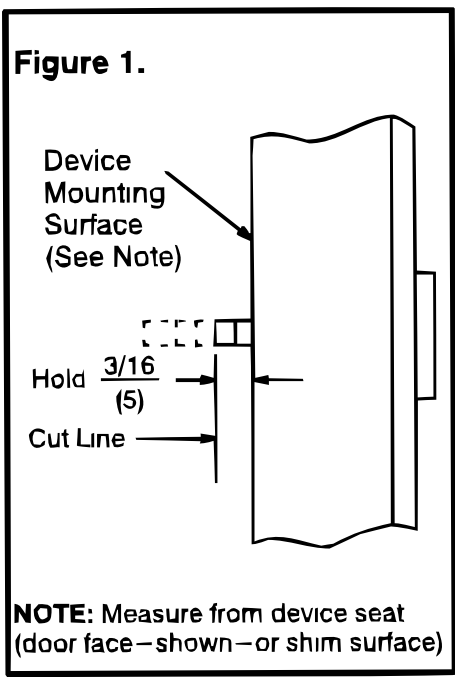

Dimensions given in  $\frac{\text{inches}}{\text{mm}}$ .