

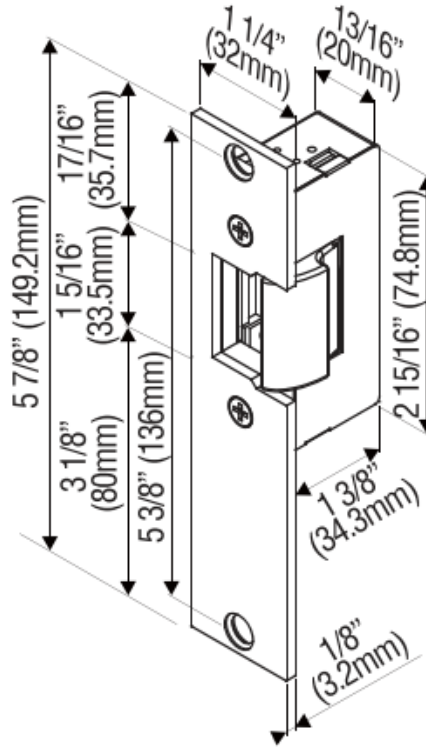

ROFU 1410 Series for Wood Jambs



Installation Instructions

1. Prepare door jamb per drawing.
2. Connect wires coming from the low voltage side of the transformer to terminal block of door strike.
3. Install electric door strike to jamb by attaching with included wood screws.
4. If replacing an existing offset electric strike, the ROFU 1410's faceplate is reversible by removing 2 Phillips faceplate screws and turning faceplate over and reinstalling the 2 screws. Alternatively, the electric strike can be installed in new installations with the short end of the faceplate at 12 O'clock position or 6 O'clock position, depending on your preference.

Note: Template dimensions (not to scale) and technical data are subject to change without notice.
Dimensions in inches and millimeters.

ROFU Security International Corp.
6818 S. 220th ST
Kent, WA 98032
1-800-255-7638
www.ROFU.com
OrderEntry@ROFU.com



ROFU 1410 Series for Wood Jambs

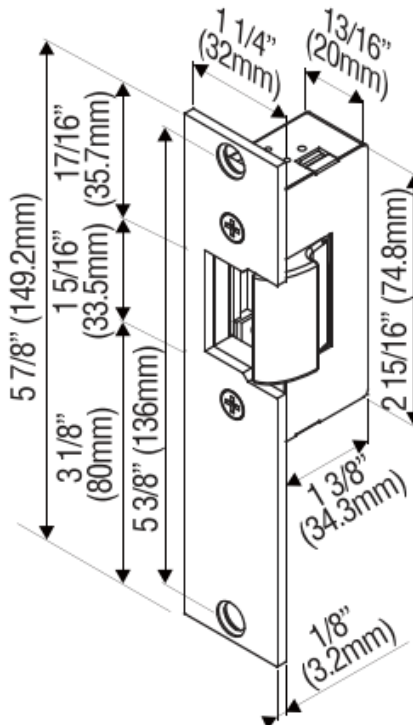

Installation Instructions

1. Prepare door jamb per drawing.
2. Connect wires coming from the low voltage side of the transformer to terminal block of door strike.
3. Install electric door strike to jamb by attaching with included wood screws.
4. If replacing an existing offset electric strike, the ROFU 1410's faceplate is reversible by removing 2 Phillips faceplate screws and turning faceplate over and reinstalling the 2 screws. Alternatively, the electric strike can be installed in new installations with the short end of the faceplate at 12 O'clock position or 6 O'clock position, depending on your preference.

Note: Template dimensions (not to scale) and technical data are subject to change without notice.
Dimensions in inches and millimeters.

ROFU Security International Corp.
6818 S. 220th ST
Kent, WA 98032
1-800-255-7638
www.ROFU.com
OrderEntry@ROFU.com