

TEMPLATE FOR MODEL 8380

FACE MOUNT

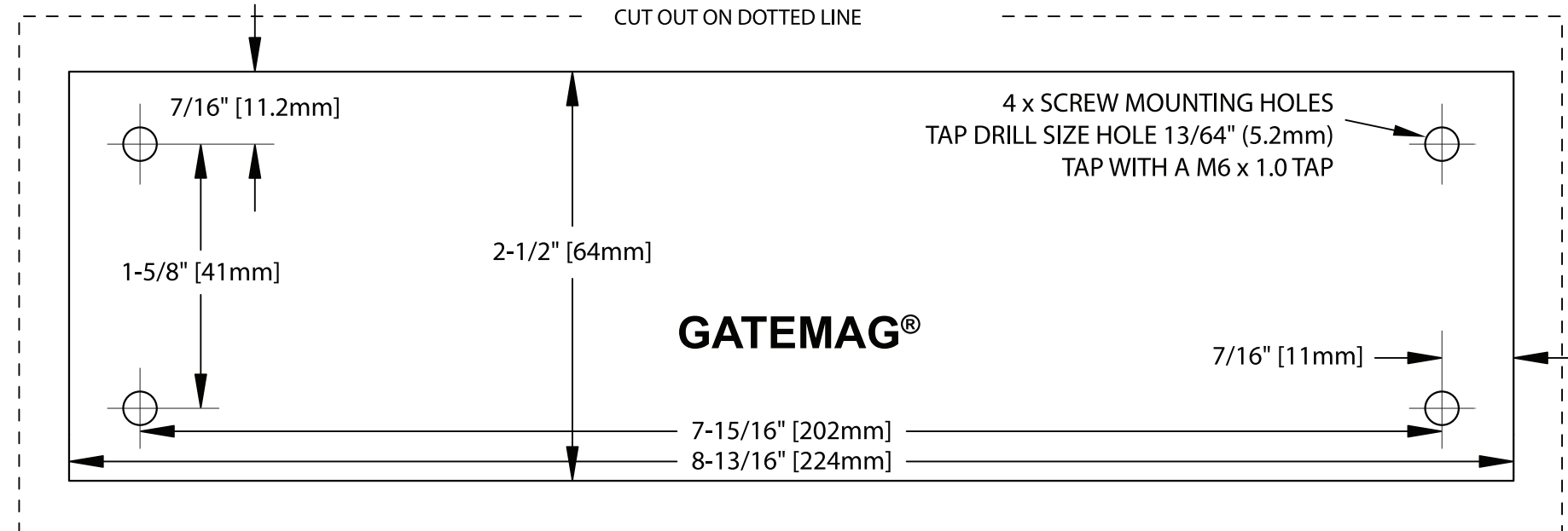

SIDE MOUNT

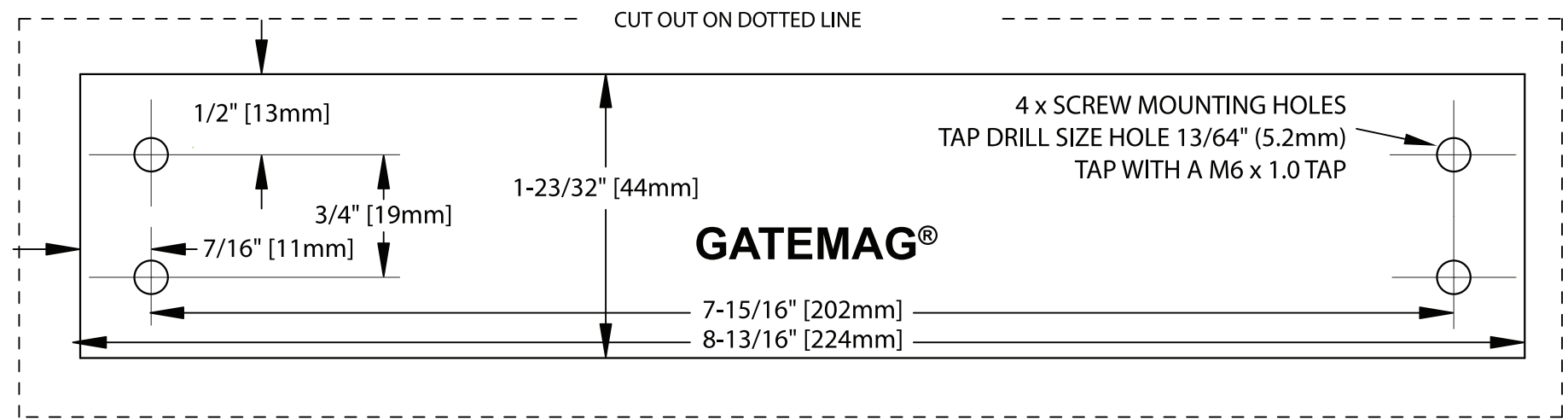

REQUIRED WHEN NOT USING RCI MOUNTING BRACKETS

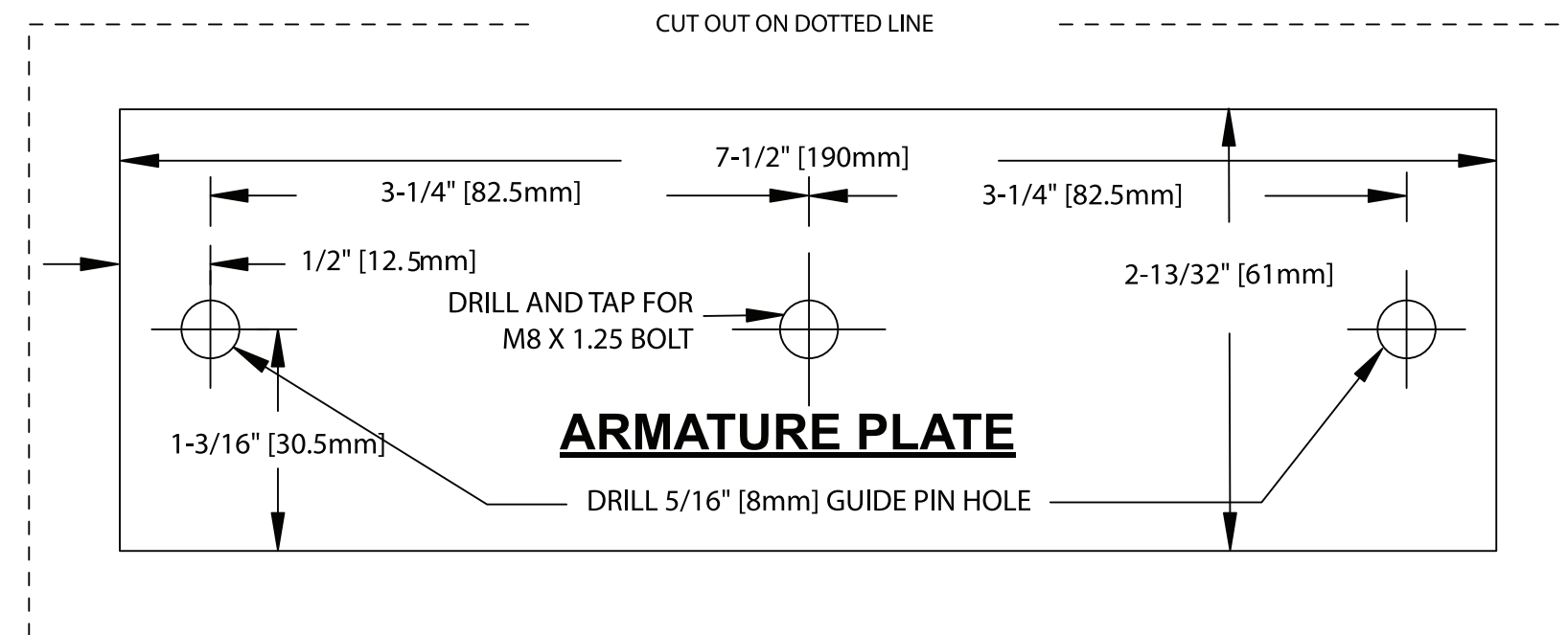

DUE TO THE WIDE VARIETY OF GATES MANUFACTURED, EACH INSTALLATION IS CONSIDERED SPECIAL AND CUSTOM MOUNTING BRACKETS MAY BE REQUIRED. MOUNTING ACCESSORIES MAY IMPACT HOLDING FORCE. GATEMAG® WILL BE MOUNTED ON THE FIXED POST AND THE ARMATURE PLATE ON THE SWINGING OR SLIDING MEMBER OF GATE. ALIGN ARMATURE PLATE TO MAKE CONTACT WITH MAGNET FACE. FOR HIGH SECURITY OR TALL GATE APPLICATIONS, RCI RECOMMENDS 2 POINT LOCKING.

NOTE: Do not use as a doorstop. This will void warranty.

MOUNTING TECHNIQUES

SINGLE SWING GATE

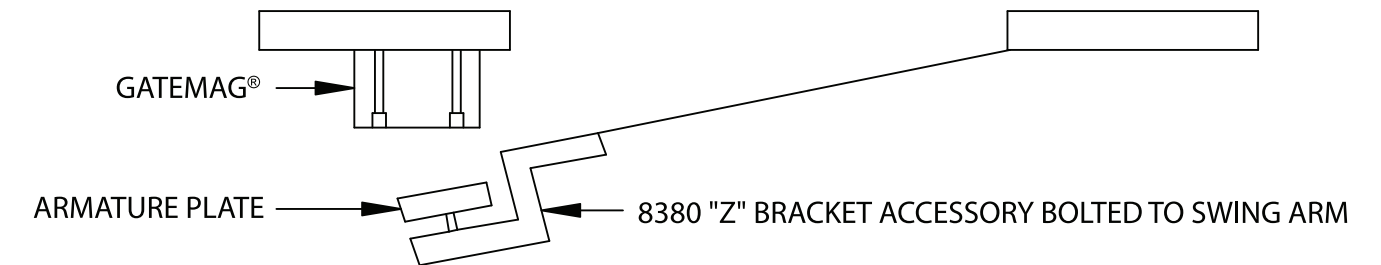

DOUBLE SWING GATE

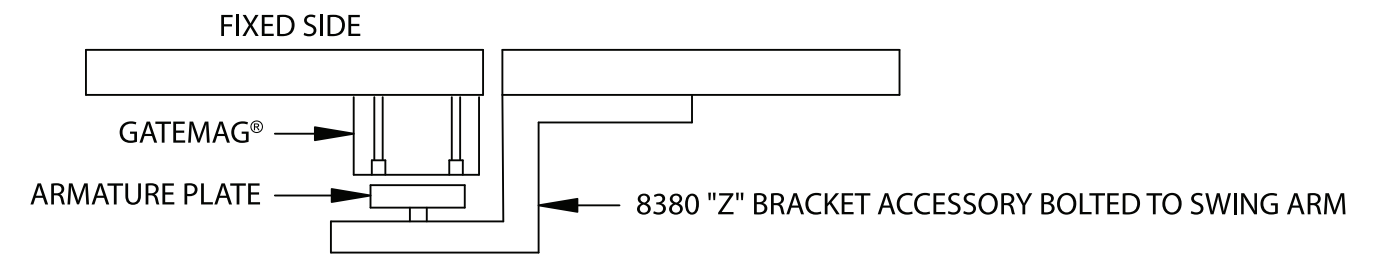

SLIDING GATE

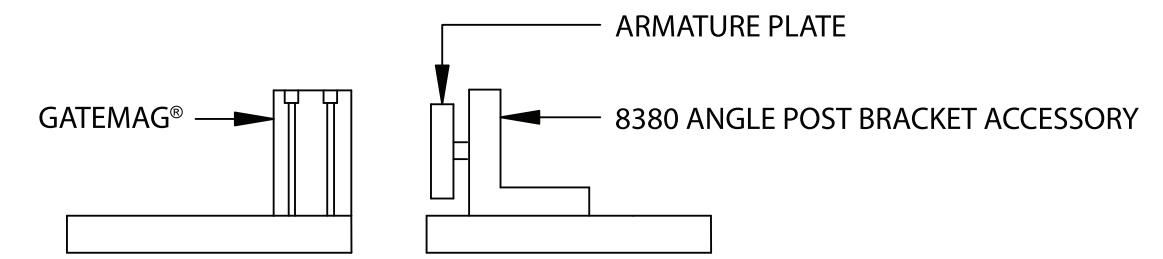

MOUNTING INSTRUCTIONS

STEP 1 - READ PRE-INSTALLATION INSTRUCTIONS

STEP 2 - CUT OUT REQUIRED GATEMAG® TEMPLATE ALONG DOTTED LINE.

PLACE TEMPLATE AGAINST FLAT PORTION OF FIXED POST OR CUSTOMIZED MOUNTING BRACKET.

DRILL 4 HOLES AS INDICATED ON TEMPLATE. (HOLE LOCATIONS ARE CRITICAL. DO NOT LET YOUR MARKING OR DRILLING WANDER).

CAREFULLY APPLY THREAD LOCKING COMPOUND ONTO EXPOSED THREADS

MOUNT GATEMAG® TO FIXED POST OR MOUNTING BRACKET.

STEP 3 - POSITION BOLT WITH RUBBER HEAD THROUGH THE ARMATURE PLATE

ADD 3 WASHERS (STEEL - RUBBER - STEEL) ONTO BOLT

CAREFULLY APPLY THREAD LOCKING COMPOUND ONTO EXPOSED THREAD

WHILE ALIGNING PINS SECURE ARMATURE PLATE TO BRACKET BY THREADING INTO M8 COLLAR

NOTE: DO NOT OVERTIGHTEN ARMATURE PLATE. IT MUST REMAIN MOVEABLE TO ALLOW SURFACE ALIGNMENT WITH ELECTROMAGNETIC LOCK

STEP 4 - WITH GATE IN CLOSED POSITION ALIGN ARMATURE PLATE TO GATEMAG® FACE.

SECURE MOUNTING BRACKET TO SWINGING PORTION OF GATE AS REQUIRED.

STEP 5 - WIRE CAREFULLY PER INSTALLATION INSTRUCTIONS.

WHEN PROPERLY INSTALLED, THE ENDS OF THE ARMATURE PLATE ALLOW A SLIGHT MOVEMENT BUT THE PLATE WILL FEEL SECURE WHEN GRASPED AT THE BOLT. THERE SHOULD BE NO MOVEMENT TO THE MOUNTING BRACKET OR HOUSING OF THE ELECTROMAGNETIC LOCK.

NOTE: UL AND ULC LISTED ELECTROMAGNETIC LOCKING DEVICES MUST BE USED WITH UL OR ULC APPROVED POWER SUPPLIES. (RCI OFFERS A FULL LINE OF POWER SUPPLIES) RCI'S 8380 ELECTROMAGNETIC LOCKING DEVICES ARE cULus LISTED AND CALIFORNIA STATE FIRE MARSHAL LISTED.

WARNING: Improper installation, maintenance, inspection or usage of the product or any related accessories or parts may cause the electromagnetic lock, armature plate and associated hardware to disengage and fall, causing serious bodily injury and property damage. Rutherford Controls Int'l Inc. and/or Rutherford Controls Int'l Corp. will not be liable to the installer, purchaser, end user or anyone else for damage or injury to person or property due to improper installation, care, storage, handling, maintenance, inspection, abuse, misuse or act of God or nature involving this product or any related accessories or parts.

