

# INSTALLATION INSTRUCTIONS FOR LEVER LOCKSET

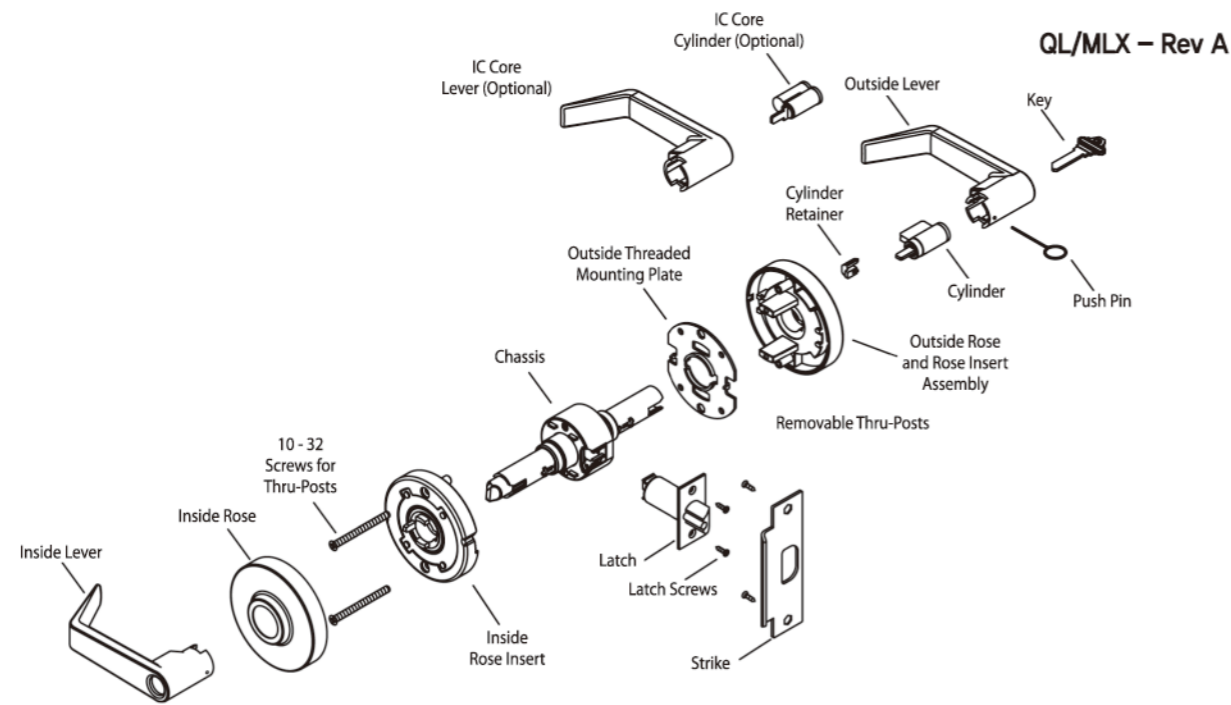

QL/MLX – Rev A

## Door Preparation

Figure 1

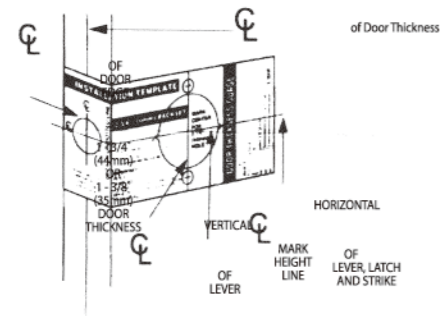

### DOOR PREPARATION:

1. Fold and apply **template** to high edge of door at desired height from floor.
2. Mark hole centers on door and door edge.
3. Drill 5/16" thru-post holes first, then drill 2-1/8" hole.

Figure 2

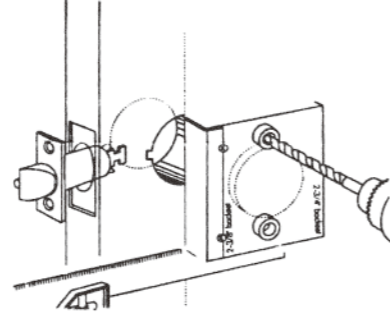

### HOLLOW METAL DOORS:

- Must have horizontal and vertical lock and latch case support provided by door manufacturer.
1. If 2-1/8" hole exists, use optional **Installation Tool** to insure accurate locating and drilling of 5/16" thru-post holes. **Drill from both sides of door.**
  2. For best results, align and clamp the tool to door before drilling.

Figure 3

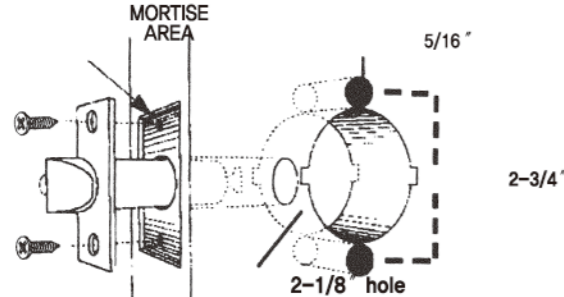

### INSTALL LATCH:

1. Drill 1" diameter hole for latch. Mortise for latch front. (Insert latch and fasten with two screws).
- NOTE:** it is important that both 1" and 2-1/8" holes are on the same horizontal center line.
- For proper alignment of lock chassis and lever, cut out two notches from each side of 2-1/8" hole for bent tabs on both mounting plates.

Figure 4

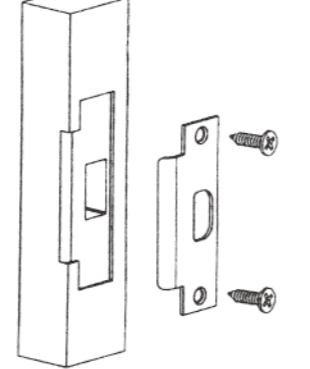

### INSTALL STRIKE:

1. Align strike with latch.
2. Trace strike outline on door jamb.
3. Mortise jamb and install strike.

## DOOR THICKNESS ADJUSTMENT

Figure 5

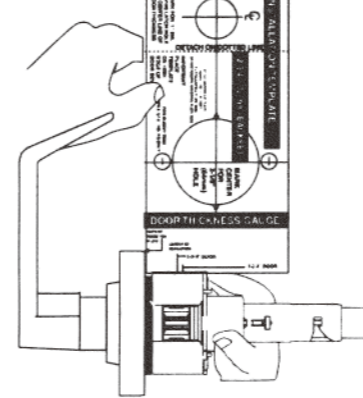

Figure 6



1. Locks are factory pre-set with for 1-3/4" thick door. Locks can be adjusted for 1-3/8" to 1-7/8" door thickness.
2. Before installation, use door thickness gauge on template as shown in Fig. 5, to check lock chassis position. Center of latch retractor should align with mark on gauge for appropriate door thickness.

If chassis is not on center, remove outside lever rose and screw chassis in or out of outside mounting plate to align with mark.

### TO REMOVE OUTSIDE LEVER WITH CONVENTIONAL CYLINDER:

1. Turn Key in cylinder 45° in either direction.
2. Depress outside lever catch with Push Pin through small hole in lever and pull lever off tube.

Figure 7



### IC CORE CYLINDER:

1. With IC Core removed, use screwdriver inside lever to depress lever latch.
2. Pull off lever.

## INSTALLING LOCK

Figure 8

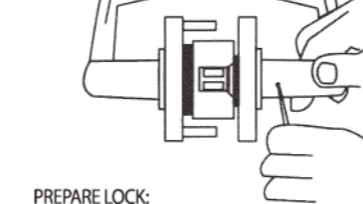

### PREPARE LOCK:

1. Remove inside lever. Depress the lever catch with the Push pin through the small hole in the lever and pull lever off tube.
2. Remove the inside rose assembly.

### INSTALL LOCK:

1. Align outside rose so rose posts enter thru-post holes in door.
2. Push lock through 2-1/8" hole from the outside so that retractor engages latch tail.
3. Prongs must engage inside lock housing. (See Figure 9)
4. Check from inside of door to see if latch is properly engaged.

### INSTALL INSIDE TRIM:

1. Place inside rose assembly and assemble using 10-32 screws.
2. Snap the rose cover over the inside rose assembly.
3. Attach inside lever.

Figure 9

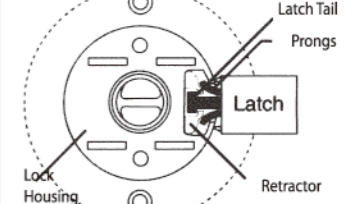

### INSTALL INSIDE LEVER:

1. Press lever on lock tube, slightly wiggle and push until lever engages lever catch and connector prongs.
2. Test lever to be sure it is on securely.

## Conventional Cylinder CHANGE / REPLACE CYLINDER IC Core Cylinder

Figure 10

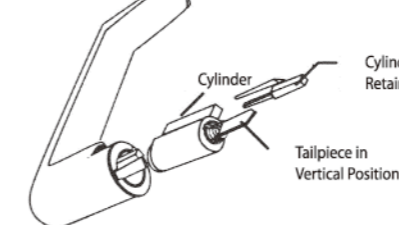

### Removal (All Functions)

1. Remove key from cylinder and pull plastic cylinder retainer from lever, then remove cylinder.

### Installation

1. Tailpiece must be in vertical position in cylinder.
2. Insert cylinder in lever.
3. Press plastic cylinder retainer into lever until flush with base of lever.

Figure 11

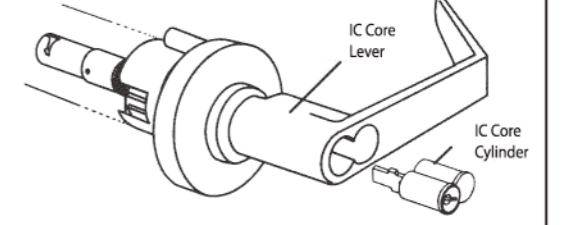

### Removal (All Functions)

1. Insert control key and turn clockwise, then pull on key to remove core.

Correct orientation of spacer for conversion of 7 pin tailpiece for use with 6 pin IC Core.

## With Conventional Cylinders REINSTALLING OUTSIDE LEVER With IC Core Cylinder

Figure 12

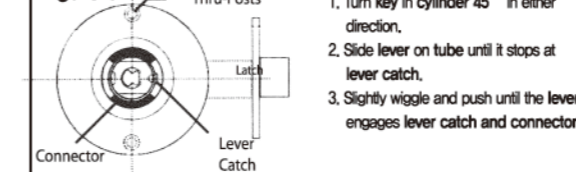

1. Turn key in cylinder 45° in either direction.
2. Slide lever on tube until it stops at lever catch.
3. Slightly wiggle and push until the lever engages lever catch and connector.

Figure 13

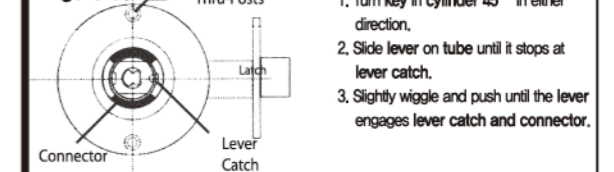

1. Turn key in cylinder 45° in either direction.
2. Slide lever on tube until it stops at lever catch.
3. Slightly wiggle and push until the lever engages lever catch and connector.

### Classroom Function Conventional Cylinder

1. Insert screwdriver into key cam slot and rotate fully in a clockwise direction.
2. Insert key into cylinder and rotate approximately 45° in a counter-clockwise direction before sliding lever with cylinder on tube.
3. Slide lever on tube, slightly wiggle and push until lever engages with lever catch and connector.
4. Rotate back in a clockwise direction and remove key from cylinder. Lock should remain in passage mode. To lock the lock; insert key into cylinder and rotate 360° in a counter-clockwise direction then remove the key. Lock should remain in lock mode.
5. Check lock for proper operation before closing door.

**Note:** For bench testing or re-assembly, mounting post must be held in vertical position

### Classroom Function IC Core Cylinder

1. Insert screwdriver into key cam slot and rotate fully in a clockwise direction.
2. Using control key, insert IC Core and lock in lever.
3. Check lock for proper operation before closing door.