

ELECTRIC EXIT DEVICE KIT INSTALLATION INSTRUCTIONS MOTOR DRIVE ELECTRIC LATCH RETRACTION

1550K-MDF FALCON 24 AND 25 SERIES

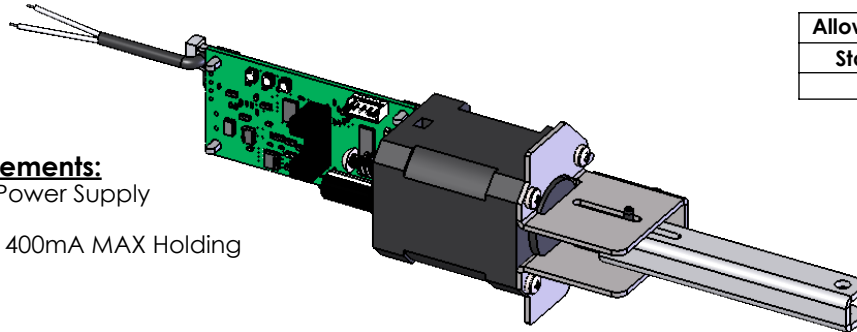

Allowable Cutoff From Device Length	
Standard 36"	Standard 48"
1.50"	7.50"

Electrical Input Requirements:

Filtered and Regulated Power Supply
Voltage: 24VDC \pm 10%
Current: 1A MAX Inrush, 400mA MAX Holding
Non-polarized Leads

PROVIDES SIMULTANEOUS ELECTRIC LATCH RETRACTION AND DOGGING (PUSHBAR DEPRESSED)

Installation:

1. Separate the channel from the pushbar assembly.
2. Remove the manual dogging assembly, if present, from the pushbar assembly and discard.
3. Locate the 1550K-MDF Kit near the hole that secured the manual dogging assembly.
4. Attach the connecting link to the pin of the pushbar assembly.
5. Attach the motor bracket to the pushbar assembly using the supplied screw through the hole that secured the manual dogging assembly. Verify the tabs on the motor bracket are located in the cutout of the pushbar assembly.
6. Attach the channel to the pushbar assembly. Verify the flanges on the motor bracket are located between the mounting features of the channel.
7. Remove the manual dogging actuator assembly, if present, from the cover plate and discard.
8. Install the supplied hole plug into the manual dogging hole of the cover plate.
9. Attach the cover plate to the channel with the manual dogging hole biased to the end of the device.
10. Apply the supplied technical assistance labels to the center case cover and the channel end cap.
Do not remove any regulatory labels adhered to the device.

2-Conductor Wire Run	
Distance	Wire Gauge
70'	22
110'	20
180'	18
280'	16
450'	14
720'	12

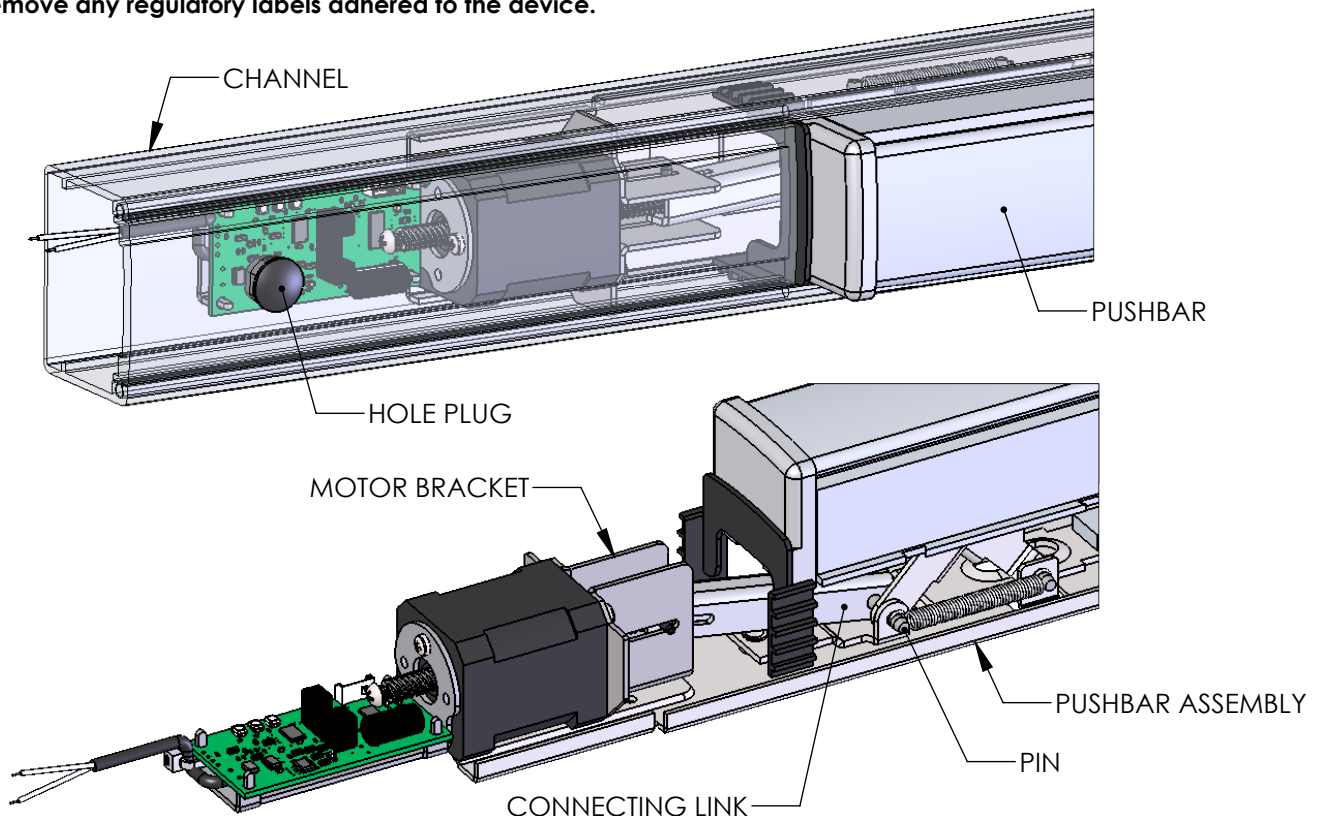

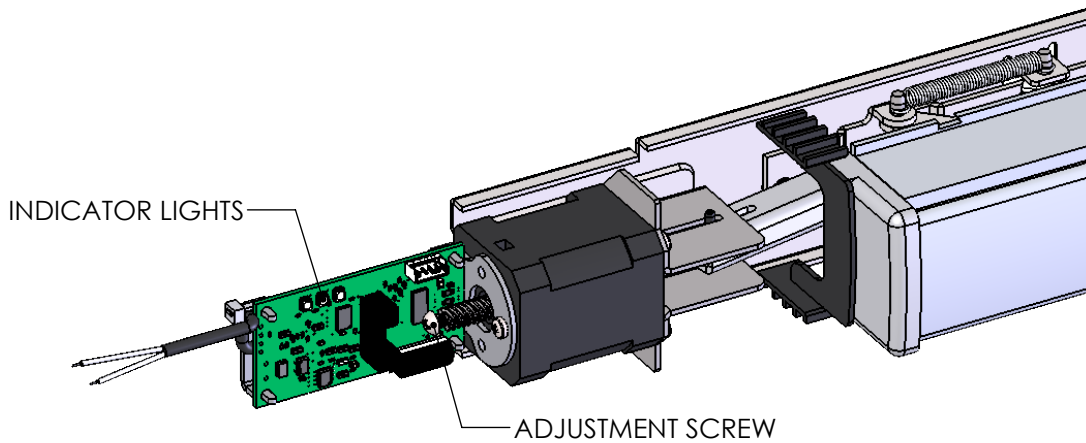

Motor Drive Electric Latch Retraction Adjustment:

1. Verify the device is properly adjusted for mechanical operation. Electric operation should not exceed the mechanical operation or there will be a high risk of damage to the device. **We suggest setting the latch retraction under electric operation at 1/16" less than the latch retraction under mechanical operation.**
2. Locate the adjustment screw in the rear of the motor assembly. Rotate the adjustment screw clockwise to increase the latch retraction or counterclockwise to decrease the latch retraction.

Onboard Indicator Light Assignments:

Maintain input power to the exit device and check the onboard indicator lights. **Remove input power before attempting a solution.**

Green (Power)	Yellow (Sensor)	Red (Error)	Indication	Possible Solution
Off	Off	Off	No Power.	Connect the wiring between the power supply and the exit device.
On	On	Off	Normal Operation. The pushbar is retracted to the dogged position and dogged; the latch is retracted by default. The device is allowed 2 attempts.	
On	Off	On	Error in operation. The pushbar did not retract to the dogged position within 2 attempts.	Rotate the adjustment screw counterclockwise to decrease the latch retraction.
On	On	On	Error in operation. Without power being removed, the pushbar went from being dogged to unintentionally being extended, and then the pushbar did not retract to the dogged position within 2 attempts.	Clear the jam condition manually.
On	Blink	On	Error in operation. The pushbar did not extend from the dogged position when the power was last removed. The device will not attempt a retraction.	Clear the jam condition manually.
On	Simultaneous Blink		Error in operation. The input voltage dropped below the specification during operation.	Decrease the wire run or increase the wire gauge.
On	Alternating Blink		Error in operation. An electronics fault was detected.	An electronics replacement is required.