

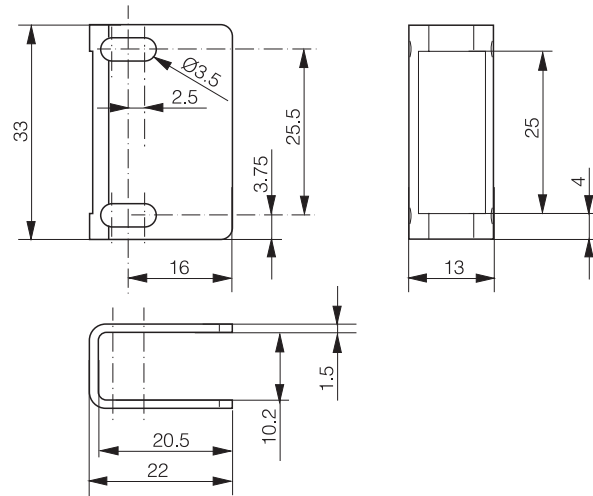

Note: The product images shown may change over time as products are updated.

Dimensions



Part Number

H30-Bracket-2

Features

- Suitable for C23PA photoelectric sensors
- Sensor mounting adjustable up to $\pm 15^\circ$
- Screws not included with bracket (screws included with sensor)

Technical Data

Material	Stainless steel V2A/1.4301/AISI 304
Weight	16 g