



Architects

# Sound Advice for Acoustics

Course Number: AIAPDH272  
4 LU|HSW

---

PO Box 449 Pewaukee, WI 53072 (888) 564-9098

[arch-support@edcet.com](mailto:arch-support@edcet.com)

# ANSWER SHEET

First Name: \_\_\_\_\_ Last Name: \_\_\_\_\_ Date: \_\_\_\_\_

Address: \_\_\_\_\_ City: \_\_\_\_\_ State: \_\_\_\_\_ ZIP: \_\_\_\_\_

Phone: \_\_\_\_\_ Email: \_\_\_\_\_

AIA#: \_\_\_\_\_

## Sound Advice for Acoustics -AIAPDH272

1. (A) (B) (C) (D)

2. (A) (B) (C) (D)

3. (A) (B) (C) (D)

4. (A) (B) (C) (D)

5. (A) (B) (C) (D)

6. (A) (B) (C) (D)

7. (A) (B) (C) (D)

8. (A) (B) (C) (D)

9. (A) (B) (C) (D)

10. (A) (B) (C) (D)

11. (A) (B) (C) (D)

12. (A) (B) (C) (D)

13. (A) (B) (C) (D)

14. (A) (B) (C) (D)

15. (A) (B) (C) (D)

16. (A) (B) (C) (D)

17. (A) (B) (C) (D)

18. (A) (B) (C) (D)

19. (A) (B) (C) (D)

20. (A) (B) (C) (D)

21. (A) (B) (C) (D)

22. (A) (B) (C) (D)

23. (A) (B) (C) (D)

24. (A) (B) (C) (D)

## SOUND ADVICE FOR ACOUSTIC DESIGN FINAL EXAM

1. The loss of energy occurring when sound waves contact or pass through materials is \_\_\_\_\_.
  - a. Lowered frequency
  - b. Sound absorption
  - c. White noise
  - d. Sound isolation
  
2. Structural building components pass sound through them by \_\_\_\_\_.
  - a. Allowing kinetic energy to pass through their porosity
  - b. Funneling it in through reflective surfaces
  - c. Vibrating on the opposite side from a source
  - d. Initial absorption and a delayed release
  
3. Increased density of sound batt insulation in wall cavities \_\_\_\_\_.
  - a. Increases susceptibility to moisture
  - b. Decreases acoustic absorption
  - c. Quickly becomes cost prohibitive
  - d. Helps with sound, but creates concerns with HVAC zoning
  
4. If \_\_\_\_\_ can pass through a gap, so can sound
  - a. X-rays
  - b. Light
  - c. Impact noise
  - d. Vibration
  
5. Reverberation Time (RT) is defined as the time it takes for an audible sound to diminish by how many decibels, once it has been created?
  - a. 35
  - b. 120
  - c. 80
  - d. 60
  
6. The Federal Agency that publishes noise standards for highways is \_\_\_\_\_.
  - a. OSHA
  - b. EPA
  - c. FHWA
  - d. DOT

7. When a deck above has been treated for sound absorption, speakers generating sound masking noise should be mounted at ceiling level and aimed \_\_\_\_\_ .
  - a. Up at the deck
  - b. Down at users
  - c. In the direction of noise generators
  - d. Horizontally along the ceiling surface
  
8. The frequency of masking sounds should be \_\_\_\_\_ .
  - a. Slightly higher than the mid-range of the hearing frequency
  - b. Near the lower end of the range of the hearing frequency
  - c. In the ultrasonic range, not actually detectable by the human ear
  - d. Constantly modulating through the spectrum of the hearing frequency
  
9. Recommended Reverberation Time (RT) for meeting or conference rooms is \_\_\_\_\_ .
  - a. Between 0.4 - 1.2 seconds
  - b. Between 0.6 - 1.2 seconds
  - c. Between 0.6 - 1.0 seconds
  - d. Between 0.4 - 1.0 seconds
  
10. Sound absorption is always \_\_\_\_\_ .
  - a. Increasingly expensive
  - b. Desired
  - c. Occurring at some level
  - d. Frequency dependent
  
11. The two characteristics by which sounds are measured, are \_\_\_\_\_ and \_\_\_\_\_ ?
  - a. Single-source, multi-source
  - b. Loudness, pitch
  - c. Exterior, interior
  - d. Music, voice
  
12. It is recommended that noise used for sound masking purposes mimic a normal building sound, such as \_\_\_\_\_ .
  - a. Sound of an HVAC system
  - b. Audible horns from an alarm system
  - c. Steam from a radiator relief valve
  - d. Exterior traffic noise
  
13. The only occupancy type, for which the IBC currently lists a noise requirement, is \_\_\_\_\_ .
  - a. Residential
  - b. Educational
  - c. Factory
  - d. Medical

14. An STC rating of \_\_\_\_\_ must be achieved before a partition is considered high performance, acoustically.
- 35
  - 42
  - 48
  - 55
15. In some cases, replacing wood studs in a wall assembly with flimsier metal studs, will result in \_\_\_\_\_.
- Reverberation like from a drumhead
  - Better STC ratings
  - Substantial cost savings
  - A need for foamed-in-place insulation
16. What is created, when vibrations are induced in one material struck by another object, travel through that material, and cause air on the other side to vibrate, is referred to as \_\_\_\_\_.
- Noise nuisance
  - Lag time
  - Reverberation
  - Impact noise
17. The time interval, between the waves of air pressure of a sound, is not only described as frequency, but also as \_\_\_\_\_.
- Pitch
  - Falsetto
  - Degree of escalation
  - Time signature
18. Which of the following is a very poor blocker of sound?
- Fiberglass insulation
  - Heavy concrete walls
  - Earth berms higher than a sound source
  - Glass windows
19. Panels of acoustic absorbing material, hung below ceilings to dampen sound, are called \_\_\_\_\_.
- Deflectors
  - Clouds
  - De-energizers
  - Acoustic focus
20. Adding a second layer of drywall to each side of a partition, that already has an STC rating of 39, will increase the STC rating for the partition to \_\_\_\_\_.
- 41
  - 55
  - 57
  - 61

21. \_\_\_\_\_ can be used to allow movement between roofing and structure, to absorb some kinetic energy from sound trying to transfer through.
- Metal roofing
  - Bushings
  - Seam covers
  - Isolation clip
22. The sound rating of any wall assembly become irrelevant if \_\_\_\_\_ .
- A door is left open
  - The wall becomes wet during flooding
  - There is visual access into the space
  - Noise on one side becomes amplified
23. A device typically receiving signals from an output channel on an amplified sound mixing board, would be \_\_\_\_\_ .
- Monitor
  - Multimedia player
  - Singer
  - Microphone
24. The goal in the acoustic design of a recording studio is \_\_\_\_\_ .
- Total acoustic isolation
  - Control of sound generated inside
  - Control of reverberation time inside
  - All of the above

## SOUND ADVICE FOR ACOUSTICS

Copyright 2017, Paul F. Spite

### Acoustics in General

Merriam-Webster defines acoustics as a science, a body of knowledge, dealing with the production of, transmission of, reception of, control of, and effects of sound.

Given that sound is a direct input into one of our five senses, it shapes our perceptions of reality and in a very real sense, our identity. Given nuances of how it affects us, there are many subjects and fields of study contained within those five broad classifications. These range from physics of sound, changes in it because of environment, physiological reactions to it, psychological reactions to it, its application in the arts, its use in medicine, and numerous subsets of each of these.

For our purposes, we will examine only architectural acoustics. We will focus on how sound from within and without, and the characteristics and quality of the same, positively and negatively affect inhabitants of environments we create. We will consider what can be done to enhance or mitigate those effects, to control or alter characteristics of such sound. We will examine how sound radiates outward from points of origin, how it moves through objects and space, and how it is perceived by people. We will consider control of sound through spatial design, material choices, and construction techniques. Finally, we will examine problems with which we still struggle, how to deal with them in specific building types, and why it is becoming so important to do so.

But first, we begin with some basic terms and concepts.

#### General Vocabulary Regarding Sound

*Sound: The transmission of kinetic energy, through vibration of an elastic medium (matter comprised of things like air, or building materials) from a source to a receiver. This energy travels outward from a source in waves of energy that can be directed, absorbed, or otherwise controlled. It is transmitted through materials or assemblies when it strikes them from one side, causing them to vibrate and set up similar vibrations in the air again, on the opposite side.*

*Noise: Unwanted sound. The most objectionable sounds are those loud enough to be uncomfortable, and ones that are intermittent, rather than continuous.*

*Noise Nuisance: An excess of noise that has a negative effect on the hearer. Noise will always be present to some degree and defined in the same two ways. It will either be acceptable or unacceptable.*

*Air Borne Sound: Energy traveling in waves, directly through the air to a receiver, like a microphone or the human ear.*

*Impact Noise: Sound transferred through the structure of a building, also labeled as structure borne sound. It occurs when vibrations are induced in one surface struck by another object. Kinetic energy of the impact travels through the material as vibrations, producing sound waves in the air around what was impacted. This kinetic energy then continues traveling as air borne sound.*

*Echo: A repeated sound, produced by sound waves reflecting from solid obstructions like walls or mountains.*

*Reverberation: Repetitive occurrences of the same sound, after its source has ceased vibrating. This persistence occurs when air borne sound is reflected from surfaces to return multiple times to a listener. It bounces around until it loses enough energy to become inaudible. Some is absorbed, causing building assemblies defining the space to also vibrate. Long lasting reverberation is detrimental to speech comprehension.*

*Reverberation Time: How many seconds it takes for a sound to diminish in intensity by 60 decibels, once the source has ceased emitting sound waves. A reverberation time of over one second creates problems with speech intelligibility. Too little reverberation time results in performed music being perceived as flat and lifeless.*

*Resonance: When a sound is prolonged by reverberation, usually beneficial to the perception and enjoyment of music being produced.*

*Building Acoustics: The art of controlling sound entering, or generated inside, a building. How well it is accomplished in construction and use of a built environment, will impact communication, health and productivity of the users of the space.*

*Sound Insulation: The effectiveness of materials in causing a loss of energy, or perceived sound, as it passes through an intervening barrier like a wall or ceiling assembly.*

*Sound Absorption: The loss of energy occurring when sound waves contact or pass through absorbent materials like leaves or insulation. Absorptive materials trap and dissipate some kinetic energy of sound waves, usually by converting it to heat. They trap varying percentages of energy within themselves, till it dissipates to below an audible range.*

*Sound Reflection: The deflection of some energy from a sound source, back toward its origin, rather than allowing all to pass through. The amount of reflection is a function of the stiffness of the material it strikes, or its resistance to vibration.*

*Decibels: The most common measurement of intensity of sound levels. This scale rates sound on human perception of relative loudness. The lowest threshold of human perception is around 5 decibels, while a rock concert can top 120 decibels. Sound at 150 decibels can destroy the human ear.*

### General Nature of Sound

Sound can be measured by two characteristics. Frequency or pitch, is the time interval between each wave of pressure. Loudness is the intensity of the wave pressure. The human ear can only comfortably handle certain ranges of both loudness and frequency.

As mentioned before, sound is basically kinetic energy, compressing air into pressure waves, moving outward from a source. There are three distinct stages in that journey. It is first generated, then moves through air or other matter like structures, and is received or perceived by a receiver like the human ear.

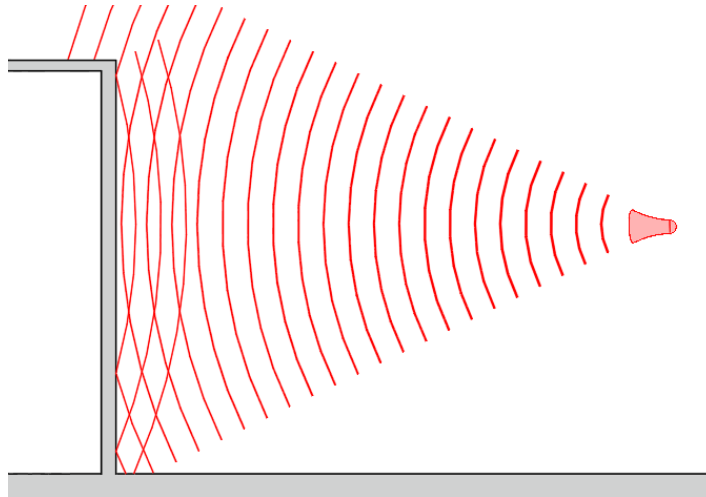

General behavior of sound

To some degree, sound forms part of every environment, including those we create. Just as any other form of energy affects us, so does sound. It can be painful or soothing, and distract from, or enhance communication.

Occupants of any environment quickly notice three acoustic characteristics of that space. One is how much reverberation of sound occurs in it. Another is the level of background noise. The third is how much noise enters the space from outside sources. These all affect decisions on how, or even if, we continue to occupy and use that space, and for what purpose. Sound studios don't often locate in spaces below landing paths of jetliners.

Inside man-made environments like building spaces, we can, and should, control sound in many ways. The quality of sound received, and its intelligibility, are important to the function of our designed environments and even the health of users. We can actively alter the nature of sound at its point of origin, the ways it is transmitted, and how it is perceived by the receiver. We can passively control it with the volume of a space, the geometry of the same, and materials used to define the space.

Sound should not be able to control us, but rather the opposite. After all, we produce most of the noise that troubles us.

### Production

Sound is generally produced in either one basic frequency, like a voice, or in a combination of frequencies, like music. Some travels to the listener in a straight path, but that direct sound is not all the listener will hear.

Unless a room is highly absorbent, listeners will receive several variations of produced sound. Because sound radiates, a portion strikes surfaces that will reflect waves back toward the listener. Some will hit surfaces that will somewhat absorb its energy, resulting in reflected waves at measurably lower decibels. If the room volume allows it, some energy will bounce between parallel surfaces before arriving at the listener as reverberation and echoes. If the space is large enough, there can be an audible gap between times when varying versions of the original sound arrive at the ear of the listener. These various versions of the sound, arriving at different times, will tend to 'muddy' what is being heard.

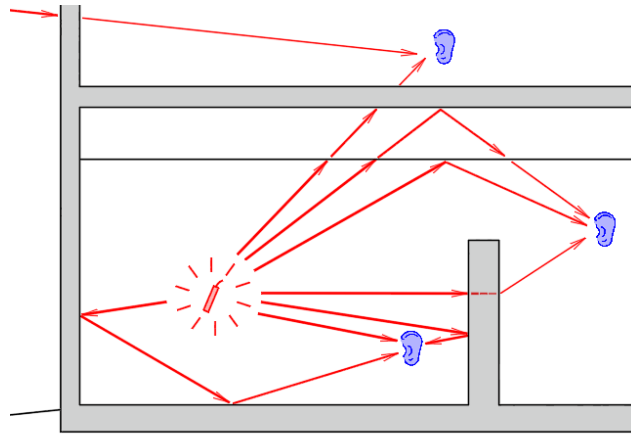

Differing paths for sound

Designing usable acoustic environments requires two pieces of knowledge. The first is the intended use of the space. The second is the combination of space volume, space geometry, absorbent materials, and reflective materials that optimize usability for that purpose. We will discuss the acoustic results of different combinations of materials, in the upcoming section on general design solutions. We will discuss acoustic concerns of different building uses, in the upcoming section on building types. In both, we explore how we can control sound in our spaces.

### Control

Noise is the number one complaint of building users. This is especially true of hospital patients, hotel guests, and diners in restaurants. A patient that cannot obtain restorative rest is a patient whose health is in grave danger. Hotel guests who cannot sleep, will not return. A good ‘atmosphere’ in a restaurant is usually one that provides perceived privacy for personal conversation. Excessive noise in schools and workplaces has been well documented to lower comprehension and productivity.

Unacceptable and unwanted sound will always require attention from designers, preferably before the environment has been constructed and found deficient.

Whether sleeping, eating, working, or learning, building occupants need to be able to use spaces as intended. This will involve examining sources of potential noise entering spaces, like sound from building systems or known external sources by the site. It will require envelope material selection and planning of adjacent uses in the building layout. It will involve prediction of generated sound moving through space, how paths of each sound might intersect, and how many times each sound should be heard at an audible level. Some study will be needed into the frequencies of expected and unacceptable noise, since different materials in envelope assemblies react differently to varying frequencies.

Stated together, all the acoustic parameters in designing spaces effective for intended use, makes success in acoustic design seem daunting. An understanding of basic principles and design approaches will simplify how we best serve our clientele. Simply put, the goal is to control sounds generated within the spaces, and the transmission of unwanted sound (noise) from the exterior, from building systems, and from adjacent spaces, into our created spaces.

### Sound Transmission

Structural building components can indirectly transmit sound energy. The energy of air borne sound waves strikes building components at one level of intensity, causing them to vibrate. This in turn causes

air, on the opposite side of the building element, to vibrate at that same frequency, reproducing the sound at a lower level of intensity, as air borne sound waves. Basically, sound energizes the building elements, causing them to vibrate like diaphragms and reproduce the sound. This is one form of structurally transmitted sound.

The other form of structure borne sound is impact noise. This results from direct impacts against parts of components of a building. Examples are; footsteps from a level above or beside the listener, people jumping on, or bumping against, building components, equipment vibrations, or basketballs hitting a wall separating an auditorium from a youth gymnasium. Impacts cause building components to vibrate, setting up sound waves on each side of the surface or structure.

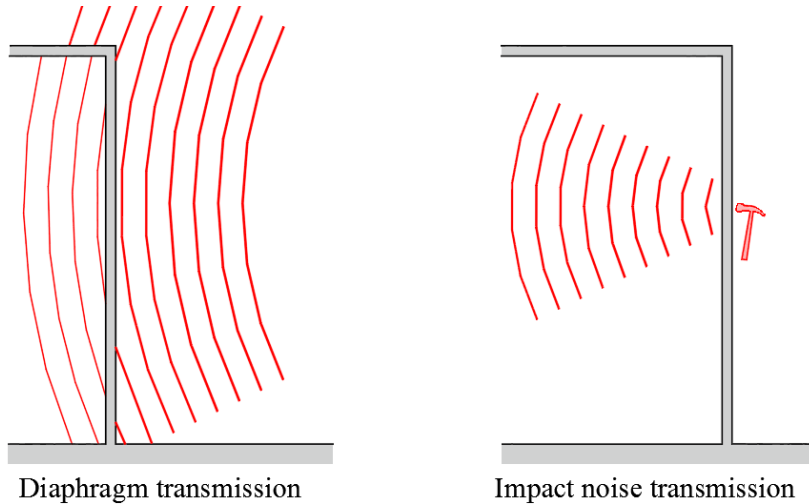

Building components react in other ways to sound transmitted through air, or air borne sound. Energy from either sound, light, or heat, coming through air and striking any material, will be affected by that material in one of three ways. Some will reflect off the material, some will be absorbed by the material, and some will pass through the material. What percentages of energy are reflected, absorbed, or transmitted, will be determined by the composition of the material, the angle at which energy strikes it, and characteristics of that energy. To reiterate, defining characteristics of the energy called sound, are frequency and loudness.

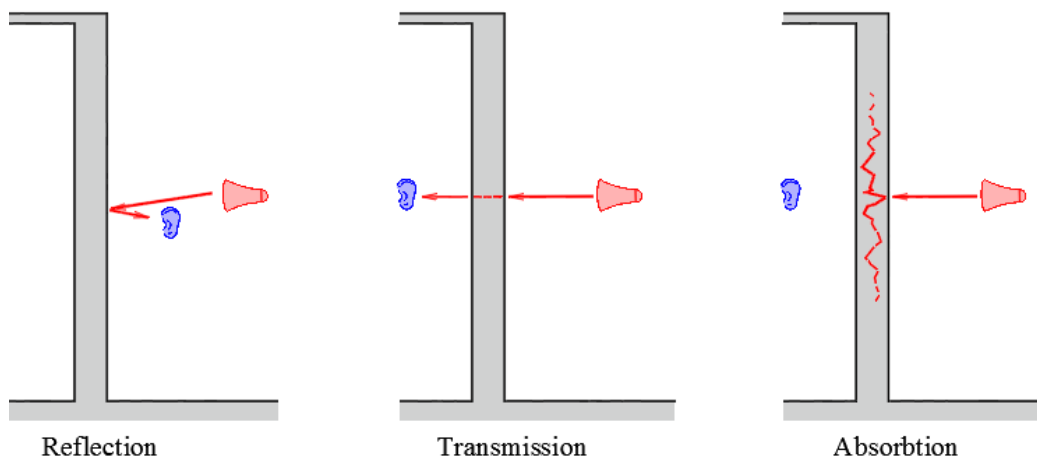

Various materials react differently to sounds with different characteristics. We will shortly examine two ways used to measure how different materials react to the energy of sound. One is “Transmission Loss,”

how effectively a material either blocks or reduces sound transmitted through it. Transmission Loss is measured as a loss of intensity, the difference in decibel levels, between sound entering and exiting material at different frequencies. The other transmission measurement, or rating commonly used for various materials, is “Sound Transmission Class.” The higher the rating, the more air borne sound that material can absorb or block, and the less unwanted sound will make its way to receivers.

Reception

There is an age-old question regarding whether a tree falling in a forest makes a sound, when there is no one present to hear it. The most obvious answer is to demand a definition of ‘sound,’ then let the definition of the term answer the question. Kinetic energy will be present, whether a human receiver is there or not. If that energy, traveling in pressurized waves of air, strikes a human ear, the sound will be recognized and recorded. If it is unwanted, it will be noise.

Whether any specific sound in a built environment is considered noise, depends on why receivers, or recipients of the energy, are in that space. A 10-decibel level of sound from an HVAC system won’t be noticed in a rock concert, but would wreak havoc with functions of a recording studio. Transmitted traffic sounds don’t matter much in a factory, but they do during a sermon. To quote an old joke, “There is nothing as beautiful as the sound of a child’s laughter. Unless it is outside your bedroom door ... at three in the morning. ... And you have no children.”

Whether noise control will be a major consideration, during the design phase of building creation, depends on the space users and what they deem to be unacceptable noise. It will also become necessary if probable noise will have unhealthy effects on receivers. And soon enough, acoustic considerations and performance benchmarks, will be mandated during the design phase for specific building types.

Audible Sound Frequencies

Frequencies of sound, the time lapse between pressure waves, are perceived differently by different users. The young can detect sound in the range of 16-24,000 Hertz (Hz). The elderly detect sound in the range of 16-4,000 Hz.

Those ranges of detectability can be put into perspective as follows. Pianos generate sound in the range of 31-4000 Hz, audible to everyone. Home stereos produce sound in the range of 16-24,000 Hz, the upper end of which is pretty much inaudible, even painful, to the elderly. The real difficulty lies in human speech, which ranges from 125-8000 Hz. Higher frequencies of our voices are well out of the hearing range of the elderly. We call this ‘hard of hearing,’ when it is really a narrowing of the audible range of sound, occurring in aging membranes called eardrums.

Environments should be designed with different acoustics in mind, if they will primarily be used by the young or the elderly.

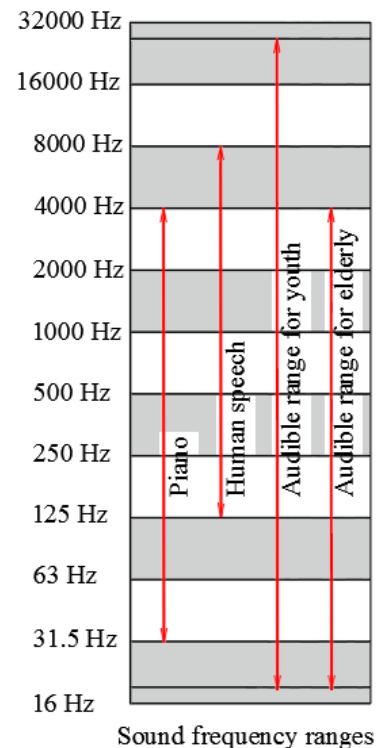

## Effects of Sound on People

It has been well documented that noise not only affects productivity, but also impacts physical and mental health. Recognizing the importance of building acoustics on health, is the beginning of optimizing the use of our built environments.

When noise is problematic, people do not adapt by becoming used to it. The effects become worse as exposure lengthens. When noise interferes with daily activities at home, at school, and at work, short and long-term problems arise that are both physical and mental.

Physical problems can be significant. Loss of sleep is an obvious problem in noisy living environments. But in every environment where users are subject to excessive noise, blood pressure rises, as do heart rates. Both increase risk of heart attacks. Frequent headaches are an obvious concern, but ulcer formation also increases as intestinal motility changes. Adrenaline increases result in increased respiration and muscle tension. Fatigue and nausea can result. The world's leading disability is hearing loss, directly linked to excessive or chronic noise. Hearing loss is the most reported, work related injury.

Mental and behavioral changes are also associated with excessive noise. Lowered attention spans result from an inability to concentrate. Unwanted sound decreases problem solving capabilities, ability to memorize, comprehension, and productivity. Hearers become more aggressive, impatient, and nervous. Curiously enough, they also become less willing to help others. Perhaps this is the source of documented social behavior issues and interpersonal problems, of people frequently subjected to excessive sound.

There are also definable economic and social costs to ignoring excessive noise in workplaces and schools. Problems with concentration and attention span, directly linked to noise, lead to poorer test scores and overall academic performance. Those so damaged, or at least hindered, will graduate to become the next generation of our society. Users of spaces are far more productive when comfortable, and audio comfort is a large part of that well-being.

Poorer productivity in workplaces leads to unimaginable economic loss for companies, with no interest or inclination to deal with problems involving sound.

Designers can mitigate problems with noise, at very little increased costs while creating building environments. Better space planning, and proper use of materials with better acoustic properties, can bring about significant improvement. We can so design, because sound behaves in predictable ways.

## **Principles of Acoustics**

If gaps exist in the envelope enclosing a space, we can do little to prevent sound entering from outside that space. But we can affect sound generated from within our built environments.

Acoustic design considerations inside a space, primarily involve air borne sound. How we, as receivers, experience sounds inside that space. We can design how sounds are generated, shaped in, and influenced by the space and its physical composition.

There is no such thing as an acoustic design that will always work well, not even for one space. Every activity in a built environment produces its own unique sounds, at different frequencies, intervals, and loudness. And each material defining the space, responds to characteristics of each sound differently. The best we can hope for is to designate acoustic properties to support most activities we know will happen in each space. If acoustics of a space seldom cross the minds of users, we probably did a good job.

So we design space, recognizing that sound energy behaves in consistent patterns.

### Sound Behavior Patterns

All sound moves from a source, along a path, to a receiver. Like water, energy of sound will seek the path of least resistance through which to flow. Altering the path sound can take, is the easiest way to exert influence over noise. The path of the least resistance for sound is gaps in construction, openings like open doors, space under doors, holes for outlets, etc... Just a bit more difficult are closed doors, typically offering far less resistance to sound transmission than wall assemblies. Windows are also points of weakness, offering diaphragms of glass to vibrate and pass noise to the other side. The best barriers to sound are solid construction assemblies.

At room temperature, sound reflects from numerous surfaces and objects before its energy is dampened to the point where it becomes inaudible. As designers, we can't control generation of sound. But we can control, to some degree, what happens to it once it enters spaces.

Three things happen to sound moving around inside spaces. Hard surfaces, like concrete or glass, reflect sound, pretty much intact, back into the space. Scattering occurs when energy comes in from one direction, but hits a surface with multiple facets, and is reflected in multiple directions. This fragments the sound wave into smaller parcels. Absorption occurs when sound energy enters a porous material, like draperies, and some is converted into heat by friction, before it can escape again as a fraction of its former self.

All three events, impacting sound within a space, will shape acoustics of that space. We can tell beforehand, via laboratory testing, effects that different materials will have on sound energy in terms of reflection, scattering, and absorption. We have even determined and charted how materials affect sounds of different frequencies.

Acoustic characteristics of materials are defined by three primary measurements, and a few other rating systems of special note.

### **Review Questions**

1. When a sound is prolonged by reverberation, that is defined as \_\_\_\_\_ .
  - a. Ricochet
  - b. Amplification
  - c. Resonance
  - d. Cacophony
2. An example of sound produced in one basic frequency is \_\_\_\_\_ , while an example of sound produced in multiple frequencies is \_\_\_\_\_ .
  - a. Voice, Music
  - b. Heartbeat, Traffic
  - c. Soloist, Choir
  - d. Guitar String, Orchestra
3. Passive ways to control sound involve \_\_\_\_\_ .
  - a. Changing the volume of a space
  - b. Changing the geometry of a space
  - c. Changing the materials used to define a space
  - d. All of the above

4. One place where a 10-decibel level of sound from an HVAC system will create problems is a \_\_\_\_\_.
- Rock concert
  - Memorial chapel
  - Office environment
  - Sound studio

### **Primary Acoustic Measurements**

#### NRC – Noise Reduction Coefficient

NRC is a single number rating of the overall sound absorption of a material, enclosed in a space, when sound strikes it from multiple angles. An NRC rating of 1, indicates perfect and total absorption of all sound energy striking that material. A rating of 0 indicates perfect reflection of that energy, resulting in no absorption whatsoever. Obviously, most materials and envelope systems fall somewhere between these two extremes. The NRC of our selected materials becomes critical in spaces where noise factors in the use of the space, or reverberation time affects its use.

NRC is not a standard or a code, but rather a rating assigned through lab testing, to determine absorption capabilities. The percentage of sound energy absorbed and not reflected, is measured at 250, 500, 1,000 and 2,000 Hz frequencies. Percentages of absorbed sound at all tested frequencies are averaged to come up with an NRC rating, rounded to the nearest 5%.

Ceiling panels with a high NRC rating provide very effective sound absorption solutions. They help maximize the user enjoyment of space and help meet acoustic performance criteria in building codes. The difference between high performance and low performance can be a relatively small gap. A ceiling system with an NRC rating of <.50 is considered low performance, while one with an NRC >.70 is considered a high performing system.

Because sound absorption is always frequency dependent, it is important to remember. NRC is an average rating, based on how well a material absorbed sound at four different frequencies, all which occur within the range of speech. An NRC rating tells little about which parts of the sound spectrum were best absorbed and which were not. For example, painted concrete block absorbs sound almost evenly across the spectrum of the four tested frequencies. Carpet absorbs about four times as much sound at 4000 HZ as it does at 500 Hz. A high NRC rating does not indicate a material will perform well at lower frequencies found with HVAC system sounds or music. And because NRC numbers represent averages, two materials with the exact same rating, may perform completely different in the same space, based on frequencies of sound found therein.

NRC lab results are also deceptive, sometimes intentionally. The lab is a perfect environment, not often duplicated in real world space, so materials may not perform as well in the real world. The method of installation will likely vary from that used in the lab, affecting results. The number is supposed to be an average, but some manufacturers quote the better performance achieved in certain of those frequencies and sort of forget to average in less impressive numbers of other frequencies. Materials may also be tested with different backings, or other materials in an assembly, that will not be present in actual installation. In that case, what was tested was an assembly, with an NRC number assigned to just one material.

NRC numbers are a very good place to begin material selection, but should not be too heavily relied upon. Laboratory testing is paid for by material manufacturers. Some manufacturers present results honestly, but it is always a good idea to seek performance confirmation from unbiased third parties.

## STC – Sound Transmission Class

Sound transmission through envelopes from one closed space to another, contributes to background noise and makes speech harder to hear and understand. It becomes important for designers to know how effective different possible wall, floor, and ceiling assemblies, will be at blocking such transfer of sound. Especially when trying to acoustically separate core spaces from ancillary use spaces. Enter the STC ratings.

*An STC rating is also a single number rating, used to rank the barrier effect of a construction assembly. In this case, what is being measured is that assembly's ability to block sound, or prevent its transmission from one closed space to another.* The higher the STC rating, the more efficient the sound barrier to air borne sound transmission. Loud speech can be easily understood on the other side of a wall with an STC rating of 30, but not so much if the wall has an STC rating of 60. In a very real sense, what is being tested is an assembly's ability to withstand use as a diaphragm to transfer sound energy from one side of itself to the other.

Like NRC, STC is determined in laboratory testing. A sound source is placed in one space and a receiving microphone placed on the other side of the assembly to be tested. Measurements are taken on the far side of the assembly in specified frequency bands, to determine how much of the source sound was blocked or absorbed. In other words, STC numbers rate sound dampening across a range of sound frequencies. Those frequencies are in the 125-4000 Hz range, the frequency of human speech. Curiously, testing is set up with, and assumes, there will be 30 decibels of background noise on the listening side.

As with NRC ratings, STC numbers are not a final answer on material performance. Because STC testing involves a limited frequency range, an STC rating gives no indication how an assembly will perform with noises like music or HVAC sounds. Also, STC ratings of barriers become irrelevant if sound is given other and easier paths to travel, than through the tested assembly. Such flanking paths can be spaces above ceilings, ducts through which noise can pass, transfer grilles, pipe penetrations between spaces, and so on. Sound can even travel between spaces by passing through doorways, reflecting against corridor walls, and entering adjacent spaces again through their doorways. STC numbers are concerned only with a single direction of air borne sound. They also only give a rating for an entire assembly, not individual materials in such an assembly.

## IIC – Impact Insulation Class

*Impact Insulation Class, also a single number rating, measures the ability of an assembly, typically a floor to ceiling assembly, to absorb or deflect sound from impacts and prevent their transmission to users of adjacent spaces, most often below.* Examples of such impact generated sounds are footsteps, objects being slid, and objects being dropped. This rating does not measure resistance to air borne sound, but rather structure borne sound.

As can be imagined, in the testing process, a machine using several hammers creates measured impact noise on top of the assembly. The loss in decibels measured below, determines the IIC rating. The higher the rating, the better the ability of the assembly to control impact sound transmission.

Multi-layer assemblies tend to dampen impact noise better than single material assemblies. A solid concrete floor ceiling component, like a Stresscore slab, will perform better if underlayment and flooring are added on top of it.

Again, it is important to remember that IIC ratings measure performance of an entire assembly, rather than individual components, to prevent passage of structure borne sounds.

## **Additional Measurements Sometimes Encountered**

### RT - Reverberation Time

Reverberation (RT) is a measure of how long sound remains audible, after being created within a room. It increases when sound can bounce back into the space from multiple reflective surfaces. It decreases when surfaces it strikes are more absorptive. RT is also highly influenced by size and volume of a space, because sound is energy that takes time to travel to and from the surfaces it strikes.

*RT is the time in seconds it takes for such a sound to diminish by 60 decibels.* For speech to be intelligible, as in spaces used for instruction, short reverberation times of less than 0.6 seconds are needed. Spaces used for musical performance need a longer reverberation time of 1.2 seconds or more, to increase the depth, richness, and warmth of the sound.

### CAC - Ceiling Attenuation Class

Ceiling Attenuation Class (CAC) is *a number used to rate efficiency of different ceiling assemblies to prevent sound passing through one ceiling, into a common plenum, and back down through another ceiling - from one otherwise enclosed space to another adjacent space.* CAC measurements become important when classrooms or offices adjoin each other, corridors, or other spaces where noise is generated. This is especially true when wall assemblies separating them do not extend all the way to the floor or deck above.

This rating for ceilings is essentially the equivalent of STC ratings for walls. It specifically comes into play when there is open plenum space above ceilings connecting two spaces, with no partition to block sound. The higher the CAC number, the less sound transferred through that ceiling. A CAC rating of less than 25 is considered as poor, while one above 35 indicates a high-performance ceiling.

### AC – Articulation Class

Articulation Class rates the amount of sound passing over the top of partial height walls, landscape partitions, or workstation furniture into adjacent work spaces. It becomes relevant in open educational or workspace environments. In this situation, what is needed is speech privacy, so sound absorption capability of the ceiling is a key factor in material selection. A higher rating for the ceiling indicates more sound absorption, with less sound making its way into nearby spaces.

Articulation Class *measures a listener's ability to understand human speech in a space.* It is expressed as a number. Better intelligibility results in the higher ratings. Lower ratings indicate less intelligibility of adjacent spoken words, therefore more distraction in the workplace. Below 150 indicates poor speech privacy. More than 200 indicates a high performing ceiling.

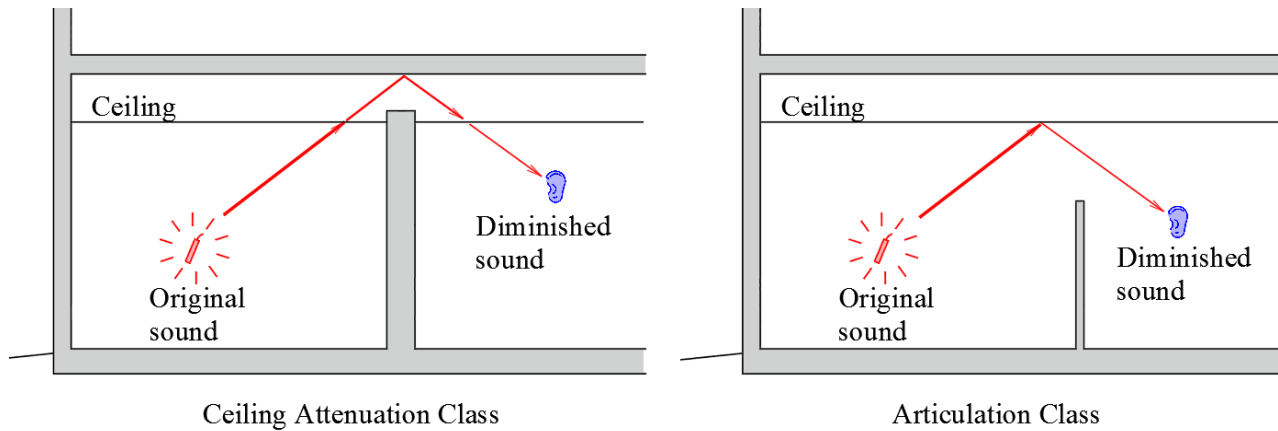

None of these rating systems indicate material or assembly performance with amplified sound.

### Amplified Sound

As a general overview, the following thoughts are given regarding intentional amplification of sound. We will touch on this more specifically, in conjunction with certain project types.

Regardless of how it is used, amplified sound is produced pretty much the same way. Sound energy enters the system from a variety of sources. These include; the human voice into microphones, sound from instruments picked up via microphone, sound from instruments directly fed into the system, and direct input from various systems that play back recorded media. This energy coming into the system is then channeled through a device to amplify it. Once amplified, sound energy is then sent back out into a space through various output devices. These include; standalone speakers, speaker array systems, systems that utilize building structures to vibrate in the lower ranges, individual speakers such as earbuds, and monitors to aid in audio analysis by performers or speakers.

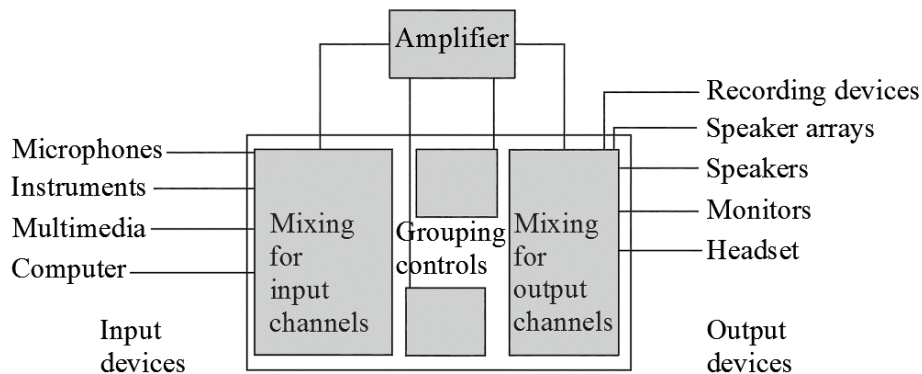

Typical sound system configuration

In educational and commercial buildings, there is often a public-address system that uses simple and often single input sources, like a media system or microphone. Output is simple multiple speakers, mounted high on walls or ceilings, to direct amplified sound down to users of spaces. These systems are most often used for voice messages, but sometimes music is piped through at low volumes. Speakers used in such systems cannot handle much volume in frequencies used in music, without damaging the speakers.

In performance and religious venues, the system for amplification is configured somewhat differently. In those, input is usually through microphones picking up voice and instrument sound, or media playback devices. This energy is sent through an amplifier, then back out through house speaker arrays and monitors. The traffic, and amount of energy moving in each direction along each path, is controlled by a mixing board. Sometimes some output is channeled through assistive listening systems using small speakers or earbuds to help with comprehension by those hard of hearing. Like speakers of public address systems, assistive listening systems do not handle much range in frequency or volume.

Some experimentation has been done, especially in larger lecture halls, with public-address systems that channel a teacher's voice down to students from ceiling mounted speakers. While good for presentation, this approach is worthless for discussion, and discourages interaction between students and teachers.

There is a peculiar side effect to sound amplification, that bears at least some thought. Most ratings used to determine efficacy of building materials to absorb, reflect, or transmit sound, involve testing based on sound in a determined frequency, at normal and natural volumes. Materials or assemblies used to create space envelopes, are often chosen, based on such laboratory ratings. Materials do not react the same to sounds at other frequencies or intensities. And sound systems, especially those with mixing boards, can grossly alter inputted sound in terms of both frequency and intensity. This unknown and unpredictable variation of sound can wreak havoc with, and completely negate, design intentions.

Regardless of whether sound will be amplified, certain consistent strategies for controlling absorption, reflection, and transmission of sound within spaces still form a basic designer's acoustical toolbox.

### Review Questions

5. STC ratings are determined by \_\_\_\_\_.
  - a. Sound meters following construction
  - b. Laboratory testing
  - c. Material thickness
  - d. Averaging listener responses
  
6. Reverberation time increases in a space when \_\_\_\_\_.
  - a. Reflective surfaces are added
  - b. Absorptive surfaces are added
  - c. Children are using the space
  - d. The volume of the space is decreased
  
7. Articulation Class rates the amount of sound passing over the top of \_\_\_\_\_.
  - a. Hedges and shrubs
  - b. Office partitions
  - c. Conference room ceilings
  - d. Sound baffles
  
8. Energy coming into a sound system is typically channeled through a device to \_\_\_\_\_.
  - a. Amplify it
  - b. Split and redirect it
  - c. Changes its frequency
  - d. Add resonance

## Design Solutions for Specific Concerns Regardless of Project Type

Using basic concepts of acoustics, there will always be three basic ways to attenuate or reduce sound.

- If possible, we can replace sources of sound with others that produce less noise. In a similar approach, we can locate sensitive spaces further from generators of noise, to lessen the acoustic impact on them.
- We can block sound from reaching a receiver with heavier, more massive materials and barricades that are less affected by kinetic energy of sound waves.
- We can interrupt the path from source to receiver with light and absorbent materials to absorb energy of sound waves.

Those three basic principles form the foundation for specific design strategies that follow, which apply equally to controlling sound in every building type.

- Resisting transmission of noise from the exterior into the interior of a space
  - This seems extremely simplistic, but while selecting a site for a project, some attention should be given to what is nearby, what kinds of sounds can be expected due to proximity to what generates them, and whether such sounds are acceptable or would need to be blocked or lessened.
  - If the site is large enough, locate structures far enough from noise generators, that sound waves have time to spread out and weaken before striking the enclosed spaces. Each doubling of distance from a source of noise, lowers its sound level by 3-6 dB.
  - If possible, lessen or block the objectionable noise at its source. An example would be an enclosure, built around an auxiliary power generator on site.
  - Use dense screens of evergreen vegetation to help dissipate and absorb kinetic force of sound waves entering the site. While these are not highly effective, they help somewhat and are aesthetically pleasing.
  - Use low walls or earth berms to deflect or totally block kinetic force of sound waves entering the site. Redirect kinetic energy up, over or around the building. This is the function of concrete walls used to separate highways and high traffic streets from adjacent neighborhoods. Such barriers may not have openings, and must block the line of sight between noise source and receiver, to be effective. The best that can be hoped for from such barriers, is lowering the sound level by 10 dB.
  - Block exterior noise that transmits sound by using the wall as a diaphragm. Use enough wall mass that it uses up a great deal of acoustic energy to vibrate the outside enclosure assembly. For example, tilt-slab concrete exterior walls block far more sound from nearby trains, than sheathed steel stud framing.
  - Reflect exterior noise with harder and denser exterior surfaces. The more reflective the face, the higher the percentage of sound energy reflected toward the source. Conversely, that results in a lower percentage of energy transmitted through the wall.
  - Absorb energy from exterior noise still coming through walls, before it can penetrate the exterior envelope. This requires use of high STC ratings for materials or assemblies forming that envelope.
  - Prevent exterior noise coming through walls, by using two separate walls around the perimeter, not actually attached to one another. There is a lot of expense with this very effective solution, but it may be necessary if very sensitive spaces must abut exterior walls.

- Most exterior walls of modern buildings are well sealed and contain some type of insulation. The good news is that, if an exterior wall will resist the transfer of heat, it will also resist the transfer of sound energy.
- Sensitive spaces can be placed on the interior and the perimeter spaces inside be reserved for less sensitive uses such as mechanical rooms, restrooms, corridors, etc. The walls surrounding more sensitive interior spaces can be highly acoustically absorbent as well, dealing at that point as a barrier to space to space noise transmission.
- Absorb acoustic energy still coming through the roof before it can make it through the exterior envelope. This will require use of high STC ratings for the materials or assembly of that roof, especially the insulation(s) used in the assembly.
- Exterior noise still coming through the roof by vibrating membrane materials like metal roofing, will easily transfer through, since such materials are usually directly fastened to supporting structural members. Isolation clips can be used to allow movement between roofing membrane and structure and absorb some kinetic energy trying to pass through. This is good practice anyway, since those two components tend to expand at different rates due to solar exposure, and need to be able to move slightly differently anyway.
- Noise will transfer through the weakest link in the acoustic envelope, whether it be a door, a window, or an air vent.
- If air can get through a closed door, so can noise. Seal doors well and use airlocks to prevent direct transmission through open doors.
- Windows are very poor blockers of sound. Glazing vibrates when struck by the acoustic energy of site noise, and that vibration passes the energy inward. Multiple panes, with air space between them, absorb some energy. Separated frames resist sound transfer by reducing structure borne sound. But by far the most effective way to mitigate leakage of sound through glazing, is to design buildings so noise sensitive spaces inside do not have glazing directly facing sound waves generated by exterior sources of noise. If possible, minimize or eliminate large expanses of glass facing site noise sources.
- All the problems mentioned above are still present, but two more can be added when windows are operable. Necessary clearances for windows to operate, also allow sound in through the gaps. If air can enter, so can sound. And of course, when the windows are open to the source of exterior noise, that is the largest acoustic gap possible.

- If exterior noise cannot be eliminated, and is still distracting, its impact can be minimized by adding a water feature to the site, thus masking the sound.

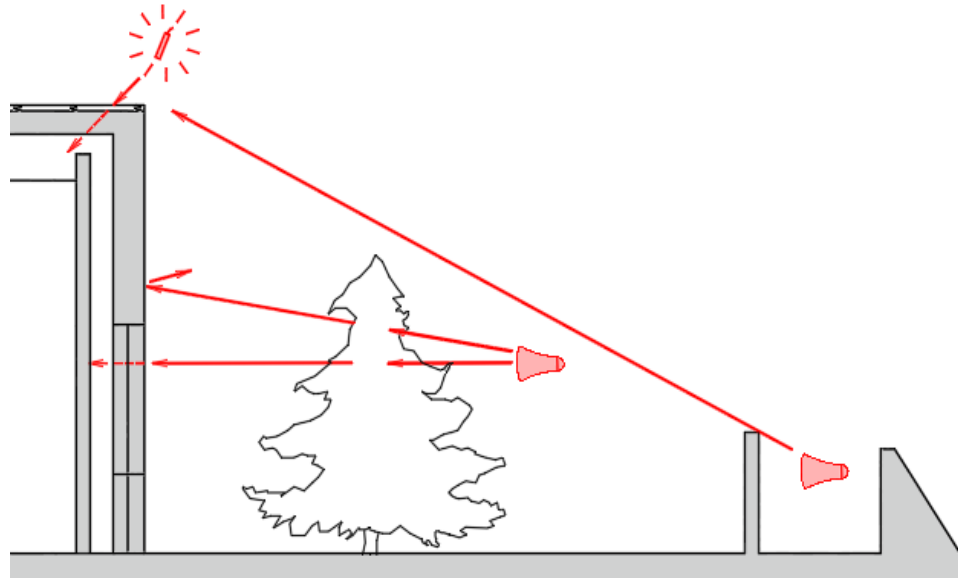

Minimizing exterior noise intrusion

- Resisting horizontal transmission of noise from space to adjacent space
  - If possible, do not locate noise sensitive spaces adjacent to spaces that generate intrusive and unwanted sound.
  - When possible, place lesser intervening spaces, like closets, between spaces that generate noise and those which need acoustic isolation.
  - Block noise coming through intervening walls by using enough wall mass that it uses up acoustic energy, trying to vibrate the assembly. Sound waves hitting a wall are trying to vibrate it like the skin of a drum. The more mass in the wall being hit by sound waves, the less the wall will vibrate and transmit sound. For example, concrete masonry walls block far more sound than steel stud partitions faced with drywall.
  - Build the assembly, and face the assembly, with materials carrying a high STC rating. Walls on the source side of noise can be faced with absorbent materials such as drapes, wall carpet, or sound absorption panels.
  - Reflect noise before it can pass through. The harder and denser the surface on the source side, the higher the percentage of sound energy that will be reflected toward the source. Conversely, a lower percentage of that energy will transfer through the wall.
  - Since light weight stud partitions are common for interior walls, mass cannot be relied on to practically reduce noise transmission. Typically, sound vibrates drywall on one side, transmitting the energy to the studs, causing drywall on the other side to also vibrate, thus passing sound through. Effectiveness of the air space in the wall, that would normally dampen the sound, is negated by continuous studs passing acoustic energy through to the other face. Such walls usually carry an STC rating of around 29, but even a STC rating of 35 is considered low performance in most environments. An STC rating of 55 must be reached for an assembly to be considered high-performance.
  - Increasing air space in a wall or window assembly will decrease the amount of sound being transferred.

- In some scenarios, spacing metal studs at 24" on center, rather than using wood studs at 16" on center, will yield better STC ratings. The flimsier metal studs create a poorer connection between drywall faces and transmit less energy.
- 3 ½" sound batt insulation, installed in the cavities of either wood or metal stud partitions, increase a typical STC rating from STC 39 to STC 48.
- Placing resilient channels at 24" on center vertically on the face of studs, and fastening drywall to the channels, rather than the studs, is an effective way to lessen direct transfer of energy from the sound source, through stud framing and beyond. The use of these channels can raise STC ratings by 2.
- Adding additional layers of drywall to faces of a typical partition, adds mass that becomes harder to vibrate. Using a second layer on each side increases partitions with an STC 39 rating, up to an STC 55. Switching from two layers of ½" drywall on each side, to two layers of 5/8" drywall, adds an additional 2-4 to the STC rating.
- Placing 2x4 stud framing inside 2x6 top and bottom plates, and staggering studs from side to side of the plates, isolates gypsum board on each side from energy striking drywall on the other side. If single layers of ½" drywall are used, this double stud system raises the rating from STC 39 to STC 45. Obviously, also increasing the thickness of the drywall, or adding layers of drywall, will yield even more significant gains.
- If even better performance is needed, two separate stud walls can be framed side by side, with an air space between them. That way, energy does not even transfer through top and bottom plates, completely interrupting structural transmission of acoustic energy. Sound insulation in the space between walls can also be continuous, since it can be uninterrupted by framing. STC ratings of walls built this way range from STC 58, with one layer of ½-inch drywall on each side, to STC 67 with two layers of 5/8-inch gypsum board on each side. There is obviously extra expense with this very effective solution, but it may still be necessary, if a noise sensitive space must be adjacent to one generating noise.
- Increased density of sound batt insulation in wall cavities, does not increase performance. The key factor to maximizing sound absorption of batt insulation in partitions, is to completely fill cavities. Specialty insulations rarely perform any better for sound isolation, than standard batt insulation.
- Avoid creating direct pathways through partitions with electrical outlets, switches, and other systems commonly installed in stud cavities. Use non-hardening acoustical sealant to fill gaps around openings and connections. It can also be used around air ducts and boots, doors, windows, and other wall and floor penetrations or gaps, resulting in a perceivable 2-3 increase in STC ratings. Outlets in walls should be sealed, with extra insulation between them and sheathing where possible.
- Switches and outlets that penetrate the faces of walls should be staggered and if possible, kept from sharing the same stud cavity. This is especially true when in proximity on either side of a partition.
- To maximize performance of partitions, use non-hardening acoustic sealant to seal the top, bottom, and perimeter of partitions between sensitive spaces.
- HVAC elements passing between spaces, like air transfer grilles, are large gaps through which sound will pass. Steps must be taken to capture and isolate sound traveling through that path.
- Pay attention to even more obvious gaps in the wall assembly between two spaces. If possible, minimize or eliminate large expanses of glass between them. Glass is easy to vibrate, which easily transfers noise. Interior windows, no matter how well constructed, will always be a weak spot in the acoustical envelope around a noise sensitive space. These windows, even when necessary, should be minimized.

- Use airlocks to prevent direct transmission through open doors. At a minimum, doors between spaces should be insulated, or of solid core construction, and be well sealed. If air can get through a closed door, so can noise.
- If every step is taken to maximize the acoustic isolation quality of intervening walls, but doors into the space perform significantly poorer, ratings of the walls will have little significance. Sound will just enter through the door. Even a highly-rated door needs to be sealed around its perimeter and have drop seals that extend down to the flooring.
- No matter what its rating, if any door to a space is left open, and many will be, noise will just enter freely.
- Assemblies separating spaces can have one or more walls that extend all the way to the bottom of the deck or floor above, containing some sound absorbent material. Gaps between the top of these walls, and the deck they abut, should be sealed with acoustic sealant. This will prevent sound from one space passing up through a ceiling, reflecting off the deck above, and bouncing back down through ceilings of adjacent spaces.
- Framing need not extend up to the deck to create acoustic separation above dividing walls. Other options are available. These include; stone wool insulation with foil facing, standard gypsum board, or limp mass loaded vinyl that is installed from the top of the partition to the deck above.
- Moreover, these acoustic barriers that extend from the top of walls to the decks above, do not have to completely encircle the spaces. They need only be placed between the space and other spaces from which noise is expected to emanate.
- If extending dividing walls up to decks above is impractical or uneconomical, batt insulation placed between ceilings and a common plenum space, with penetrations such as lay-in lighting troffers and ductwork also protected, will help reduce sound transfer.
- Hallways placed outside walls of much higher spaces, with structure supported by the walls of such higher spaces, will transfer impact noises like footsteps, directly into the side of the higher space. If such hallways abut acoustically sensitive spaces, their floor structure should be supported independently of the dividing wall.
- Improperly finishing joints between sheets of drywall, can impact the noise resistance of the same. Joints between multiple layers should always be staggered. They should be taped well enough that the compound used, when it dries over time, will not create cracks allowing sound to pass through. Poor construction can lower laboratory tested rating of an assembly by up to 15 off the STC rating.
- Field testing STC ratings of operable partitions are often up to 10 below laboratory ratings. This is due to poor installation, improper sizing, and flanking paths sound can take through common gaps left in place. If insulated bulkheads are not installed above these, allowing sound to bounce up through ceiling plenums and back down into adjoining spaces, operable partitions do very little to block sound transfer.
- An easy method to find sound leaks, is to turn lights on in one space and off in an adjoining space. Anywhere light can transfer, sound will also penetrate.
- In summary, to maximize acoustic performance of a demising partition, the following steps can be taken; use two separate walls of framing with space between, use two layers of overlapping drywall on each side of the stud framing, select lighter-gauge metal channel studs, stagger electrical outlets and switches so they are not in the same stud space, completely fill stud cavities with sound-absorbing insulation, extend either the partition or another acoustic barrier from the top of the wall to the deck above, and seal all joints and penetrations completely using non-hardening caulk. Minimize or eliminate glazing. Then remember to shut the door.
- If sound transfer still cannot be contained to a tolerable level, sound masking becomes the next step in making spaces more user friendly.

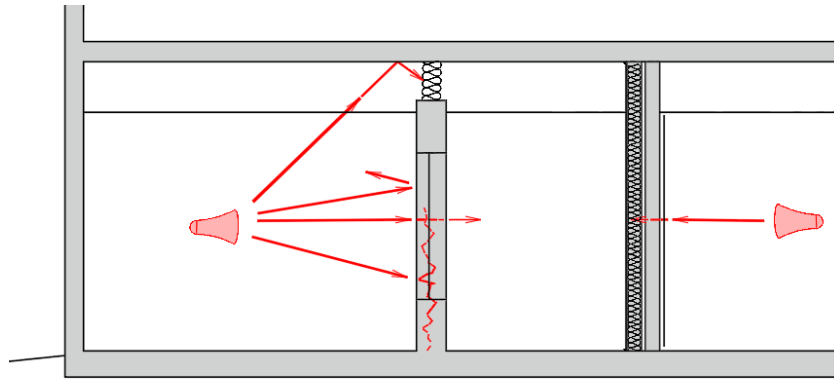

Minimizing transfer between spaces

- Resisting vertical transmission of noise from space to adjacent space, including structure borne sound.
  - If possible, do not locate noise sensitive spaces above or below spaces generating intrusive and unwanted sound.
  - The more mass and the stiffer the floor above or below, the less sound will be transmitted through it. Use enough mass that it uses up a great deal of acoustic energy to vibrate the assembly.
  - Isolate the ceiling of the assembly from the structure. Isolation clips or resilient channels can be used when fastening materials directly to the structure. More effectively, space can be included in assemblies and components like suspended ceilings can be hung by flexible wire or hangers that do not directly transmit vibrations.
  - Use materials in the floor-to-ceiling assembly that are absorbent and have high STC ratings, like acoustical ceiling materials and carpet to muffle impact sounds.
  - Continuous acoustic underlayment below flooring, with a high impact insulation (IIC) rating, will absorb some impact noise from footfalls. This closed cell foam is engineered to reduce structure borne sound by isolating it to the space in which it is generated. It is placed on the subfloor, then a plywood or gypsum concrete layer is placed on top. The underlayment acts to isolate impacts, dissipate some of the energy, and reflect the rest back up into the space above. A plywood or concrete floor floats above the underlayment and provides substrate for the finish flooring.
  - Insulate ceilings below floors of spaces generating unwanted sound, to absorb energy coming from above. When counting on this for acoustic isolation, weak spots in the barrier must be addressed. These are gaps produced by lay-in lights and duct penetrations through the ceiling.
  - When possible, lighting fixtures and other items located at ceiling level, should be surface mounted.
  - In very sensitive spaces, that do not involve large spans, a ceiling system can be installed with no connection to the structure above, allowing no sound transmission by direct transfer.
  - Vertical penetrations (gaps) between levels, like pipe chases, will need to be sealed. Duct penetrations may need air transfer silencers installed to prevent direct sound transfer.
  - Relatively thin walled structural columns, supporting floor structures above, will transfer noise from impacts against the columns to the structure and space above. These types of columns should be isolated from potential impact, by boxing them in with framing that does not attach directly to the columns.

- In summary, air borne sound through floor to ceiling spaces can be minimized by; adding sound absorptive insulation in cavities between floor framing, adding resilient channels, adding more layers of gypsum board to increase ceiling mass, and caulking all penetrations with acoustic non-hardening sealant. In suspended acoustic ceiling assemblies, specially designed insulation can be placed to improve both acoustic and thermal performance of the assembly. This will also decrease sound transfer over the top of adjoining partitions.
- In summary, structure borne sound through floor to ceiling spaces in multi-story spaces can be minimized by; using flooring like carpeting or cushioned vinyl flooring to absorb sound, installing a continuous high impact insulation class material between subfloor and finish flooring, and isolating structural components that easily transfer sound down and through intervening floor to ceiling assemblies.
- If sound transfer cannot be contained to a tolerable level, sound masking becomes the next step in making spaces more user friendly, at least acoustically.

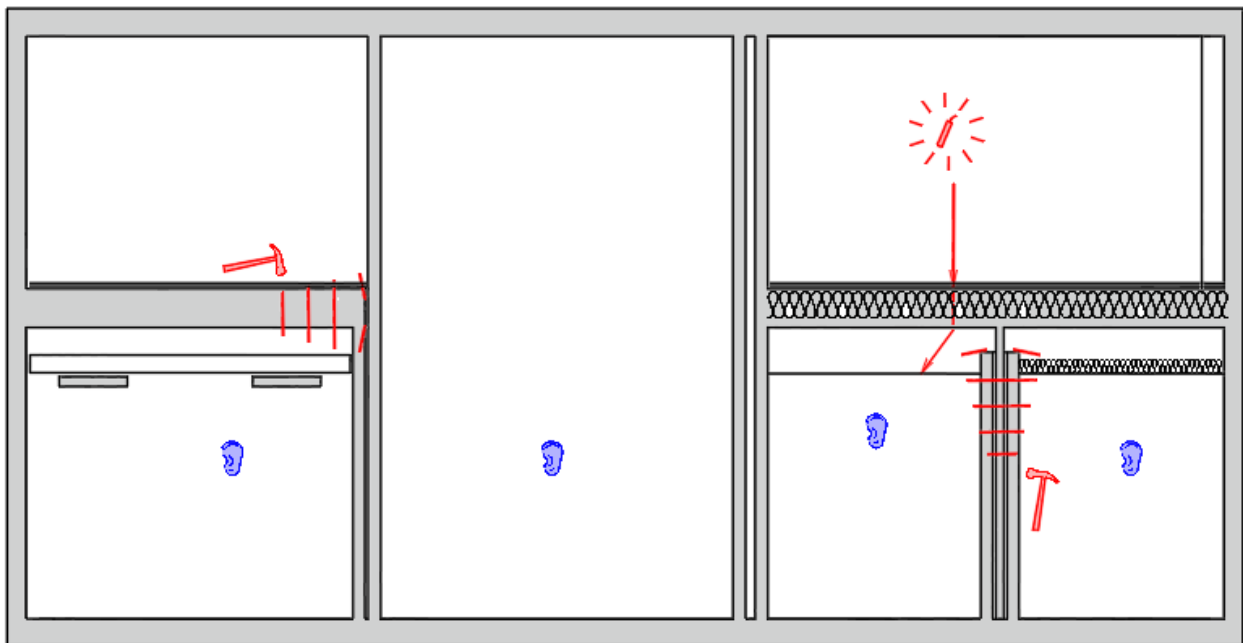

Minimizing vertical transmission

#### Controlling reverberation time of sound generated within a space

- To dampen additional reverberation enabled by increased volume of higher ceilings above stage areas, back walls and often side walls are usually treated with absorptive materials.
- Carpet on the floor will also reduce reverberation time. But unless walls and ceilings also provide absorptive surfaces, there will still typically be too much reverberation for good comprehension of speech.
- A rear wall should almost always be covered with an absorptive material. Unless sound is prevented from reflecting off a back wall, the bounce back returning to the performers will be very distracting. It will also muddy clarity of sound reaching the audience. The further the distance to the back wall, the muddier the combined sound of what comes from the stage, mixed with what comes back from the rear wall. Curved back walls, often

used to accommodate fan seating configurations, complicate matters by focusing and intensifying sound bouncing from the rear wall. A very absorptive material should be used on such walls.

- Parallel surfaces allow sound to ricochet back and forth between them, setting up echoes that wreak havoc with speech comprehension. Absorptive material on the one or both parallel surfaces can prevent this, but the problem can be handled more directly by building walls that are not parallel, and ceilings that are not parallel to floors.
- Seating areas, when reasonably full, contain people in clothing. That cloth, hit by sound waves, will provide some absorption and reduce reverberation time. But since seats only half full will provide less absorption, to get consistent results, seats should be upholstered and as absorptive as the clothing that may or may not occupy them.
- A staggered, trey, or faceted ceiling can be used to disperse sound energy. If ceilings in direct line with energy coming from the stage are absorptive, this will lower reverberation time. If they are sloped and reflective, allowing energy to bounce down to the audience, they will increase reverberation time.
- “Clouds” of acoustic absorbing material can be hung from ceilings to dampen sound and reduce reverberation time.
- Overhanging balconies distort sound waves entering the space below them. To keep sound from becoming incomprehensible to those seated below them, balconies should be no more than twice as deep as they are high.
- Baffles that rotate behind screens, containing absorptive material on one side and reflective material on the other, are sometimes utilized. These can be mechanically rotated as a performance switches between speech and music, to decrease reverberation time, or increase it. There are two problems with these. The first is a thumping noise created to some degree, as baffles spin and come to rest in a new position. The second is the potential for human error. If the wrong surface is presented to the audience at the wrong time, by human operator or computer, speech will suddenly become unintelligible and the music flat and lifeless.
- Walls can also be changed for other types of presentations, by covering reflective surfaces with manual or motorized drapes. These can be changed ahead of time to prepare an auditorium for primary functions of either speech or music. Such drapes require storage pockets, and side aisles need to be wider, to accommodate additional depth of the drapes.
- One seemingly obvious, but rarely used solution for reducing reverberation time, especially when amplified sound systems are used, is directional sound control. This is using one set of microphones and speakers for speech and another set for music. Speakers used for music are set low and aimed high to reverberate against hard ceiling surfaces, increasing resonance for the music. Speakers used for speech are set high and aimed low toward a floor with absorptive flooring material and upholstered seating, to kill reverberation. Microphones are color coded for each use. The obvious drawback is the cost of two sets of microphones and speakers. Which might be less expensive than wall materials with changeable surfaces, mechanical or otherwise.

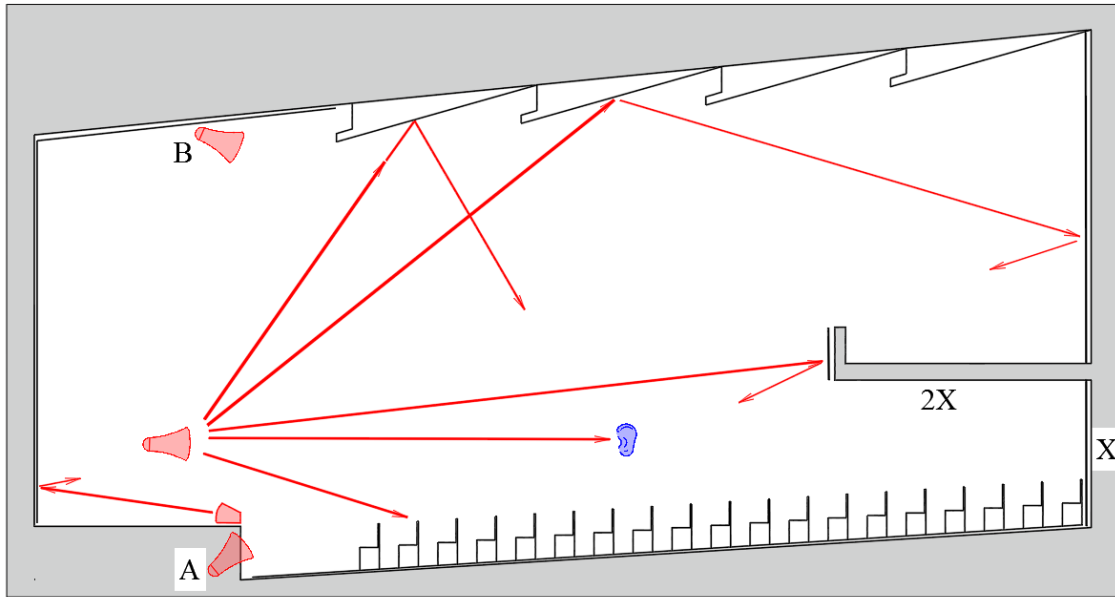

Controlling reverberation time

- Masking unwanted noise with sound generating systems
  - Background noise should have a neutral quality, possibly being designed to mimic other familiar building sounds, like airflow over diffusers.
  - Masking sounds should slightly higher than the mid-range of the hearing frequency spectrum.
  - Speakers for masking systems are ideally mounted above the ceiling, facing up to the deck, so sound reflects, disperses, and filters back down through the ceiling. If the deck above has been treated for sound absorption, then speakers need to be aimed downward at the ceiling. In both cases, avoid allowing open return air grilles to become a huge leak, down through which a much louder version of the masking sound will flow.
  - Sound masking should not exceed 45 to 50 dBA, or workers will raise voices to compensate, defeating the purpose of having the system in place.
  - Systems that have levels of 30 dBA or higher, make it difficult for the hearing impaired to understand speech.
  - Sound masking should extend into adjacent areas, so there is no abrupt and noticeable difference as users move between spaces.
  - Systems may need to be turned down during off hours, to allow security personnel to detect unusual noises.
  - Masking systems should be incrementally increased from low to desired levels, to allow workers to become accustomed to the sound and used to ignoring it.
  - The white noise system should be a different one than is used for intercom systems. Otherwise, each time the intercom is used, it will interrupt sound used for masking.

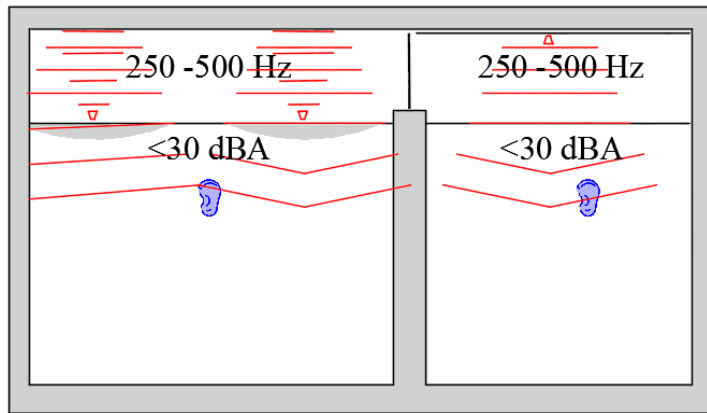

Sound masking systems

- Controlling system sounds, especially HVAC noises, that enter a space
  - Try not to place mechanical equipment adjacent to occupied space, especially when noise levels of NC-40 and below are required in the occupied space.
  - Duct silencers are usually perforated metal baffles that absorb noise. They come in various sizes and configurations to accommodate different types of ductwork, and generally begin at around 24" in length. Some are filled with fiberglass, although healthcare and school applications require that no fibers be added to the airstream. In those cases, a film barrier separates fibrous acoustic materials from the airstream.
  - When air transfer ducts are utilized, or common return air grilles are used to allow air up into a ceiling plenum, air transfer silencers can be added to minimize noise transfer through those paths.
  - Air transfer silencers are also useful when a room, like a mechanical room needing a high STC rating to separate it from adjoining spaces, is penetrated by large horizontal openings like return air grilles. Another technology to reduce leaks created by such openings through noise containment envelopes, is a cross talk silencer. These can be used to satisfy both air transfer and noise isolation requirements.
  - Packless silencers are sometimes used in healthcare and school applications. They do not employ acoustic absorbing material, but rather tuned chambers to absorb noise. They are also used in environments like labs and industrial applications, where corrosive contaminants may be in the airstream.
  - Lined return boots are sometimes used, but have several drawbacks. Field fabrication results in poor quality control. They also require additional labor, have additional support requirements, and limit installation due to space constraints in shallow plenum conditions. For these reasons, air transfer silencers are used instead. These can be fabricated in controlled conditions and easily installed directly below mechanical equipment.
  - Air transfer silencers are not as efficient in noise reduction as HVAC duct silencers. But they do allow overall STC or CAC (Ceiling Attenuation Class) to be preserved. This can be important for assemblies containing suspended acoustic ceilings and common ceiling plenums. The use of air transfer silencers ensures that air transfer openings do not become flanking paths for sound transfer.

## Review Questions

9. Using dense screens of evergreen vegetation to help dissipate and absorb kinetic force of sound waves is generally considered \_\_\_\_\_ .
  - a. A LEED certified solution
  - b. Not highly effective
  - c. A best practices solution
  - d. Completely useless
  
10. Acoustic barriers from tops of walls to decks above need only be placed \_\_\_\_\_ .
  - a. Between a space and other spaces generating noises
  - b. Above light fixtures which penetrate ceilings
  - c. Above windows between those spaces and adjacent hallways
  - d. Around the entire perimeter of the space to be protected
  
11. Baffles that rotate behind screens, containing absorptive material on one side and reflective material on the other, are sometimes utilized to \_\_\_\_\_ .
  - a. Change the frequencies of sound striking them
  - b. Change the aesthetics of a performance space
  - c. Soften the tone of sound energy reflecting from them
  - d. Change the reverberation time of the sound
  
12. Duct silencers are usually \_\_\_\_\_ .
  - a. Perforated metal baffles that absorb noise
  - b. Intermediate sections of flexible duct material
  - c. Reflective sheets that redirect motor noise inward
  - d. Flexible mounts below HVAC machinery

## Design Considerations by Specific Project Type

There are specific acoustic concerns encountered in primary building types encountered by designers. Most concerns and problems regarding occur in multiple project types, so specific solutions to these problems have already been addressed in the section immediately preceding this one. But the concerns to be addressed, vary based on how the built environments will be used. Those we will also cover briefly, for a few primary building types.

### Speaking Venues: Auditorium

*Use:*

These structures contain at least one significantly large space, used for performances involving vocal or musical presentations. What gets complicated, is when a single performance alternates between those two primary types of sound, repeatedly, during the same performance.

*Site Concerns:*

Detectable noise entering the space from outside, during a performance, would obviously be detrimental to the purpose for which the space is constructed. If there is a source of noise nearby, especially one of high intensity like a train, airport runway, or highway, steps must be taken to block, absorb, or reflect that

acoustic energy before it transmits all the way through the exterior envelope. This requires some focus on the STC rating of the materials or assemblies creating that envelope.

If there are weak spots (gaps) in an otherwise sound resistant envelope, like expanses of glass or doorways sufficient to handle large volumes of traffic, it may be necessary to have a secondary sound barrier inside to further prevent sound transmission into performance spaces.

#### *Intent of Design:*

The intention is to create performance space that allows for intelligible speech, but still enhances the experience of listening to music. For the first, there must be significant absorption. The second requires enough reflection to create a longer reverberation time. Producing both demands a careful balance of materials, directional control of sound energy for each presentation type, an ability to mechanically alter the material composition of the space at will, or several of these solutions.

#### *Known Acoustic Design Considerations:*

- For a mix of music and vocal presentations, the space should provide a reverberation time between 1.0 - 1.5 seconds.
- HVAC systems that supply cooling and fresh air for large numbers of people, can be noisy. Their operation can disrupt performances, if an effort is not made to lower system noises to an acceptable level. This is especially critical in spaces used mainly for vocal presentations.
- Reverberation time on the stage should be approximately the same as within the audience area, so performers hear what is being received. This is difficult, because there is often a higher ceiling above stage areas to allow for backdrop storage and deployment. Steps must still be taken to equalize reverberation times between the two areas.
- Sound will enter from the lobby area, along with patrons leaving and returning to their seats. Doors that seal very well can help with this, but an airlock or vestibule, between the lobby and each entry, is more effective.
- As discussed earlier, noise entering an auditorium through walls separating adjoining spaces can be abated in several ways.
- Unless sound is prevented from reflecting off a back wall, the bounce back returning to performers will be distracting to both them and their audience.
- Curved back walls also have an undesirable side effect of focusing and intensifying reflected sound.
- Parallel surfaces permit sound to echo, wreaking havoc with speech comprehension.
- If not taken into consideration during design, auditoriums will sound much different when almost all seats are full, then when the space is only partially occupied.
- Careful attention should be paid to materials used for flooring, and where they are utilized. Carpet should be used in aisles, if only to muffle impact sounds from footfalls.
- Realizing that sound moves outward from a platform or stage in an expanding wave, for better or worse, based on the geometry and materials of the space they define, ceilings will shape and direct sound being produced.
- Strategically placed “clouds” of acoustic absorbing material can be used, at or below ceiling levels, to dampen unwanted sound from reflecting down in certain directions.
- Overhanging elements like balconies, or ceilings enclosing lower adjacent portions of an auditorium, will distort sound waves reaching people in the space below them.
- Panels with absorptive material on one face and reflective on the other, that can be rotated or changed quickly, can be used to alter reverberation characteristics of an auditorium. This is tempting technology that seems to solve a problem of mixing sound types in one presentation, but it can be disastrous if the technology used to make the change goes wrong.

- An older version of the solution above, is the use of wall surfaces that are reflective for music, that can then be covered with drapes for other presentations.
- Having a performance area higher than the seating, helps to better disperse sound to the audience.
- Larger spaces can be divided by operable walls covered in acoustical material. But unless they have high STC ratings, seal to the floor, and hang from bulkheads containing framing and sound insulation extending to a deck above, acoustic performance of these operable partitions will likely be disappointing. Without the abovementioned precautions and enhancements, operable partitions will not adequately acoustically isolate one space from another. And once such panels are pulled, acoustic characteristics of the spaces created on each side will change.

### Speaking Venues: Lecture Hall

#### *Use:*

This large space will be used for vocal presentations, usually educational in nature. Some will also involve multi-media presentations. What gets a little complicated, but not enough to change the design of the space for that need, is when multi-media presentations also involve music.

#### *Site Concerns:*

Site concerns are the same as for auditoriums described earlier.

#### *Intent of Design:*

The intention is to create an educational space to facilitate intelligible speech and audiovisual presentations. To optimize the primary use of this space, there must be significant sound absorption. This requires careful selection of materials and envelope assemblies, as well as directional control of sound waves.

#### *Known Acoustic Design Considerations:*

- For clarity of speech, for audience members to clearly hear and understand a speaker, reverberation time is recommended to be less than 1.0 seconds.
- Reflective front walls and ceilings help project sound to the entire room, while materials selected for back and side walls should absorb sound to prevent echoes and lower reverberation time.
- Parallel surfaces allow sound to echo, wreaking havoc with speech comprehension. Angle ceilings, so they are not parallel to floors, and walls, if possible, so they are not parallel to one another.
- If not taken into consideration during design, auditoriums will sound much different when seats are filled, then when the space is partially occupied.
- Sound will move out from the speaker in an expanding cone of energy. Make sure seating is not placed in a dead zone close to the speaker, but outside of that cone of sound. The sound of the spoken words should not return and reach such seats as reflected sound, having already been diminished by absorbent side and back walls to below the level of audibility.
- A presentation area higher than the lowest seating, and tiered seating that rises as it gets further from the speaker, helps in better dispersion of sound to the audience.
- As before, too much noise from the HVAC system, or too much noise entering from adjacent spaces, will impact speech comprehension.
- Larger spaces can be divided by operable walls covered in acoustical material. Special care must be taken to insure operable partitions acoustically isolate one space from another. And once such panels are pulled, acoustic characteristics of spaces on each side will change.

## Speaking Venues: Meeting or Conference Room

### *Use:*

These smaller spaces are used for vocal presentations, usually informational in nature. Some will utilize multi-media presentations, but even these will primarily involve speech, rather than music. With all presentations, there should be a minimum of distraction resulting from poor acoustics in the space.

### *Site Concerns:*

These spaces are often located on exterior walls, having significant glazing to allow in natural light. Site noise impacting the wall, especially glazing, from nearby sound generators, will potentially be a problem. Such sound will need to be blocked or absorbed.

### *Intent of Design:*

The intention is to create an educational space allowing for intelligible speech and audiovisual presentations. To optimize the primary use, there must be significant acoustic absorption. This will require careful selection of materials and envelope assemblies, as well as dampening of sound generated by HVAC systems, the exterior, and adjacent spaces.

### *Known Acoustic Design Considerations:*

- For clarity of speech, for audience members to clearly hear and understand speakers, reverberation time is recommended to be between 0.6 - 1.0 seconds.
- In rare cases, a sound system may be used to enhance a presentation, but amplification of sound will be rare in these types of spaces.
- The ceiling material or assembly should be of sound absorptive materials. In one interesting twist, the area above a conference table can be surfaced with reflective materials, to help direct sound from a presenter back down to others around the table. Then the rest of the ceiling, including that above the seating, is treated with acoustic absorbing material.
- These room envelopes often contain glazing, opening to adjacent hallways. Sound easily passes through glass by vibrating it, passing the sound to the other side. Transmission of sound from these rooms is usually unacceptable. And contrary to popular belief, draperies typically provide very little absorption. Glazing should instead contain separated frames, air space between panes, and be minimal in size.
- Along this same line, information dispensed, and discussions in such rooms, is often highly confidential. Care must be taken to eliminate gaps in the sound isolation of these spaces. Walls containing absorptive materials should extend to, and seal to, floors or decks above.
- To eliminate flutter or echoes from parallel walls, which most of these spaces will have, walls opposite the normal speaking position, and at least one side wall, should be an assembly or be faced with materials having significant sound absorptive capability.
- If a public-address system is used throughout the facility, and / or a sound masking system is in place using speakers located in ceilings, controls should be available to turn speakers down or off in conference rooms.

## Performance Venues: Dance Hall

### *Use:*

These large spaces are used to play live or recorded music, by which to dance. Social events held in these, usually involve large groups. When used for receptions, some consideration must also be given to speech comprehension.

*Site Concerns:*

Detectable noise entering from outside, especially during a speech, would be detrimental. If there is a source of noise nearby, especially one of high intensity, that acoustic energy will need to be blocked, absorbed, or reflected before it can transmit through the exterior envelope.

Large expanses of glass, or doorways sufficient to handle large volumes of traffic, are weak spots in the acoustic envelope. It may be necessary to have a secondary sound barrier inside, to further prevent sound transmission into the dance hall.

*Intent of Design:*

The intention is to create a space allowing for intelligible speech, that will still enhance the experience of dancing to music. For the first, there must be significant absorption. The second requires enough reflection to create a longer reverberation time. This mix will require careful balance of envelope materials, directional control of various sources of sound waves, an ability to mechanically alter the material composition of the space at will, or a combination of these solutions.

*Known Acoustic Design Considerations:*

- For enhancement of music, while still allowing comprehensible speech, the space should provide a reverberation time between 1.0 - 1.2 seconds.
- Music and vocal presentations in these spaces will often involve amplification of sound. Controlling the location of speakers will allow for directional control of amplified sound.
- Ceiling mounted speakers, primarily for use in vocal presentations, will distribute comprehensible speech across a large room. Comprehension improves if the floor below, in the seating areas, is somewhat sound absorbent to reduce potential echoes.
- HVAC systems need to be large to provide cooling and fresh air to large numbers of active people. Such systems can be noisy enough to disrupt speech comprehension across a large space, if effort is not made to lower system noise to an acceptable level.
- Sound will enter from lobby areas, along with users leaving and returning to their seats. Doors that seal very well can help with this, but an airlock or vestibule between the lobby and each entry is even more effective.
- As discussed earlier, there are many ways to abate noise entering a dance hall, through walls adjoining other spaces.
- Unless sound is prevented from reflecting off a back wall, the bounce back returning to performers will be distracting to them and the audience.
- Side walls should be left partially reflective, to help increase reverberation time and enhance presentation of music.
- Curved walls have an undesirable side effect of focusing and intensifying reflected sound.
- Dance halls will sound much different when seats are filled, then when the space is only partially occupied.
- Careful attention should be paid to materials used for flooring and where they are utilized. A hard surface will obviously be used for dancing. When unoccupied by dancers, that surface will reflect sound further beyond it.
- Sound moves outward from a platform or stage in an expanding wave. Based on their geometry and the materials used, ceilings will shape and direct sound being produced on stage.

- Wall surfaces that are reflective for music, can be altered before use by a function that is mainly vocal in nature, by pulling drapes out of recessed pockets, and lining the walls with them.
- Having a performance area higher than the seating, helps disperse sound to the audience.
- Geometric ceilings, like domes, barrels, or vaulted ceiling areas, will result in focused noise and interesting patterns of echoes. That effect can be lessened by lining them with absorptive finishes.
- Larger dance halls can be divided by operable walls covered in acoustical material. Special care must be taken to insure operable partitions acoustically isolate one space from another. And once such panels are pulled, acoustic characteristics of spaces on each side will change.

### Performance Venues: Movie Theatre

#### *Use:*

These theaters usually contain multiple large spaces, used for presentation of movie shows that include dialogue and music soundtracks. Spaces need to be designed for audience enjoyment of both.

#### *Site Concerns:*

If there is a source of detectable high intensity noise nearby, it will need to be blocked, absorbed, or reflected before it can enter spaces where movies are being shown. This will require some focus on the STC rating of the materials or assembly of that envelope.

Large expanses of glass, or doorways sufficient to handle large volumes of traffic, are weak spots in the acoustic envelope. It may be necessary to have a secondary sound barrier inside, to further prevent sound transmission into theatre spaces.

#### *Intent of Design:*

The intention is to create spaces that allow intelligible dialogue, but still enhance the experience of theme music and soundtracks in shows. For the first, there must be significant absorption. The second requires enough reflection to create a longer reverberation time. It will also be very important to limit acoustic distractions from one theatre to adjacent theatres.

#### *Known Acoustic Design Considerations:*

- For showing of movies, spaces should provide a reverberation time between .80 - 1.2 seconds.
- HVAC systems that supply cooling and fresh air to large numbers of people are noisy enough to lessen enjoyment of movies, if steps are not taken to lower system noise to an acceptable level.
- Sound will enter from the lobby, as patrons leave and return to their seats. Doors that seal well can help with this, but an airlock or vestibule between the lobby and each entry is more effective. Often, entry hallways run perpendicular to lobbies and are faced with absorbent materials to trap and dampen any sound entering from the lobby.
- As discussed earlier, there are many ways to abate noise entering a theater, through walls adjoining other spaces.
- Unless sound is prevented from reflecting off a back wall, sound bouncing back will be distracting to the audience.
- Movies often use high intensity sounds, like explosions, as special effects. Walls separating movie theatres from one another should be designed to block these high intensity noises as a worst-case scenario. Keep in mind that STC ratings are generally established in laboratories for sounds up to 125 - 4000 Hz. Bass lines from scores, and the sounds of explosions, usually fall well below that range, so STC ratings will not be an accurate indicator of performance.

- Curved back walls, unless extremely sound absorbent, will focus and intensify reflected sound.
- Parallel surfaces allow sound to echo, wreaking havoc with speech comprehension.
- Movie theatres will sound much different when full, then when they are only partially occupied. The seats should be as sound absorbent when empty, as they are when full of clothed audience members.
- Because speakers are often high and aimed down at the audience, careful attention should be paid to flooring materials and where they are used.
- Sound moves outward from a platform or stage in an expanding wave. Based on their geometry and the materials used, ceilings will shape and direct sound being produced on stage.
- Strategically placed “clouds” of acoustic absorbing material can be used at or below ceiling levels, to dampen unwanted sound from reflecting down in certain directions.
- Mounting speakers higher than seating will help in better dispersion of sound to the audience.
- Buildings are sometimes subdivided into individual theatres by operable walls, covered in acoustic absorption material. Unless they have high STC ratings, seal to the floor, and hang from bulkheads containing framing and sound insulation extending to a deck above, sound blocking performance of these operable partitions will likely be disappointing. Given that different movies will be shown on either side of such dividing walls, these are better made of parallel walls, separated from one other, extending from floor to decking above.
- Keep the depth of movie theatres relatively short, to prevent a noticeable lag between the action on the screen and associated sounds reaching audiences in the rear.

#### Performance Venues: Recording Studio

##### *Use:*

Out of necessity, and practical issues of sound isolation, this space is a smaller enclosure than other performing venues. This is where audio tracks are recorded, usually for music, but sometimes for verbal presentations. These are typically for recording performances of which, copies are intended to be sold.

##### *Site Concerns:*

If there is a source of detectable high intensity noise nearby, significant steps must be taken to block, absorb, or reflect that acoustic energy before it can get into the recording studio. The goal is to completely shut out such noises. This will require focusing on the STC rating of the materials or assembly of that envelope, adding mass to absorb kinetic energy of the sounds, and isolating the recording studio inside another envelope. Careful attention must be made to eliminate gaps in the outer envelope.

##### *Intent of Design: Control of reverberation time inside*

There will be multiple goals to attain in the creation of these spaces. The first will be to get as close to total acoustic isolation of the recording studio, as can be attained in the budget. Sound generated inside or outside, entering the studio while very expensive recording is taking place, will negate the purpose for which the space is created. All sound being produced and recorded in the recording session must be controlled. To this end, reverberation time, the reflection of sound within the space, needs to also be completely controllable.

##### *Known Acoustic Design Considerations:*

- Mechanical unit sounds must be kept below NC15-20 levels and that sound level should be kept constant during a recording session. If constant, it can be identified and electronically removed later during editing.

- An acoustically efficient airlock is critical to eliminate unwanted sound from entering studios from points of access. Signage should also be available to warn away possible intruders while a recording is being made.
- The outside envelope of the building containing the studio, and the walls of the studio itself, should have enough mass to effectively block unwanted sounds.
- There should be an airspace between exterior walls and the walls of the recording studio. Absorptive materials can help with the intensity of sound, but cannot replace the benefits of sound isolation.
- There should be no structural members capable of transmitting sound, spanning between the envelope of the recording studio and any other structure.
- The walls of the studio itself should have an STC rating of at least 60, although even that may not adequately block low frequency sounds.
- One school of thought is to control the interior reflection of sound, by making every surface inside as acoustically inert and absorptive as possible. Then desired reverberation time is added into the recording electronically. That sometimes produces sound with too much bass in it to easily modify.
- Another school of thought is to surface the inside of the studio with a combination of reflective and absorptive materials, that can be modified to create the desired balance for what is being recorded. This lessens the amount of expensive editing that will be required later. This modification of a studio enclosure can sometimes be accomplished with interchangeable panels, or reversible panels having both types of surfaces, that can be reattached and reconfigured with desired absorptive or reflective surfaces facing into the space.

### Performance Venues: Home Theatre

#### *Use:*

This small setting is used for presentation of movie shows that include dialogue and music soundtracks, in a home. A home theatre usually seats four to twelve people in an intimate setting.

#### *Site Concerns:*

There are few site concerns that will impact these spaces, as there are few objectionable and intrusive noises in a residential environment. Those which do exist, such as the sound of mowers, blowers, etc., can usually be easily overcome by eliminating windows.

#### *Intent of Design:*

The intention is to create spaces that allow for intelligible dialogue, but still enhance the experience of theme music and soundtracks. For the first, there must be significant absorption. The second requires enough reflection to create a longer reverberation time.

#### *Known Acoustic Design Considerations:*

- For showing of movies, spaces should provide a reverberation time between .80 - 1.2 seconds.
- HVAC systems can be noisy enough to enjoyment of movies if nothing is done to lower the system noise to an acceptable level, at least in the space housing the home theatre.
- Since windows are not especially desirable in a movie setting, and are a large gap in the acoustic isolation of a home movie theatre, try not to have any in that space.

- Sound from the home theatre will be more of an issue than sound entering it from elsewhere in the home. Doors into the home theatre that seal very well will be useful. Add weather-stripping and floor sweeps to solid core doors.
- Walls that are partially faced with absorbent materials, can be used to trap and dampen sound from movies. Two things should be kept in mind. STC ratings will not serve as an indicator of how well residential walls will dampen lower frequency sounds found in special effects. And a completely acoustically dampened room is not the goal. That would prevent theme music and movie scores from being enjoyable.
- A home movie theatre envelope that is physically isolated, by an air space, from the rest of the home, would be ideal. In practice, that is hard to achieve, at least in any floor / ceiling assemblies that will normally enclose the space.
- Unless sound is prevented from reflecting off the wall behind the audience, echoes bouncing back will be very distracting.
- Parallel surfaces will allow sound echo, possibly causing problems with speech comprehension.

### Dining Venues: Dining Hall / Restaurant

#### *Use:*

These large spaces provide a place where patrons can sit down at tables and counters to consume food prepared in nearby, usually contiguous kitchens. Activities can include waiting to be seated or served, patrons entering, ordering food, transmission of food or drink orders to kitchen staff, transportation of prepared food from kitchen to tables, consumption of food, consumption of beverages, conversation at and between tables, enjoyment of live or prerecorded music or performances, paying for food in various ways, patrons exiting, clean-up of tables and dishes, and resetting of tables. As can readily be imagined, most of these activities generate significant levels of sound.

#### *Site Concerns:*

Most people who dine out, expect to be able to converse. Excessive noise, entering the space from the exterior, would obviously impede that. If there is a source of noise nearby, especially one of high intensity like a train, airport runway, or highway, that energy will need to be blocked, absorbed, or reflected, before it can transmit through the exterior envelope.

Large expanses of glass, or doorways sufficient to handle large volumes of traffic, are weak spots in the acoustic envelope. It may be necessary to have a secondary sound barrier inside, to further prevent sound transmission into the dining space.

#### *Intent of Design:*

The intention is three-fold. The dining space should be acoustically buffered from exterior noise. Adjacent spaces should be shielded from noise generated within the dining hall. Noise generated inside must also be mitigated to the point where the dining experience does not become unpleasant to patrons attempting conversation. The goal is for patrons to notice the atmosphere, not the noise.

#### *Known Acoustic Design Considerations:*

- In a space where adult and juvenile patrons can touch food and then touch walls, having surfaces that can easily be cleaned becomes important. Washable surfaces are generally reflective of sound, adding to reverberation time. The same thing is true of flooring for areas where food is to be carried or consumed. This somewhat, although not totally, limits using sound absorptive

surfaces, used to decrease reverberation time and add to speech comprehension, to materials used in ceilings.

- To help decrease reverberation time, while still controlling hygiene issues, acoustic treatments can be placed high enough on walls to be out of reach of small children. Easily removeable sound absorptive treatments can also be used, and simply cleaned or replaced as necessary.
- Open dining areas, where sound can reverberate, may need some type of acoustic treatment separating them into smaller spaces.
- Almost any palette of finish materials can be used, so long as the mix between absorbent and reflective materials is designed to achieve desired results.
- There are specific areas that generate higher intensity sounds, such as places for dishwashing, cooking areas, and serving areas involving food lines with servers talking to patrons. Buffer spaces, like refrigerated display racks or sound absorbing dividing walls, can be placed between these spaces and the dining areas.
- Many dining spaces have large expanses of glass to access exterior views. That gap in the acoustic envelope should be addressed. This is especially true in urban settings, where traffic noise assaults the glass. At a minimum, glazing should be insulated with an air space between panes. Ideally, the frames are also separated, so kinetic energy from exterior sounds does not pass directly through. Even better, seek to place glazing facing in a direction, other than towards generators of excessive noise.
- Cafeterias and dining halls are often used for other functions, involving assembly or recreation. The flooring will not change, but removeable acoustic wall panels may become important in such other uses. Reconfiguring these will either increase or decrease reverberation time, based on their deployment.
- There will be a 'back' wall to dining spaces, usually opposite where food is being taken in and out of a servery or kitchen. The 'back' wall should be treated with acoustically absorbent materials or assemblies, to prevent sound from the 'front' from echoing back into the space and muddying speech comprehension.
- Domes or vaulted ceilings, while providing a great look, will focus reflected sound down into certain areas beneath them. Treating them with acoustic absorptive materials will help.
- If patrons struggle to hear others at their own table, because of chatter from nearby tables or kitchen sounds, they will eventually find other places to dine. This is the real cost of failing to take acoustic design into consideration up front.
- More space between tables and booths may be one answer to more acoustic privacy, but there is obviously a cost to that solution in seating fewer customers.
- HVAC systems for these spaces are typically high volume and potentially high noise. Taking steps to lessen that intrusive sound will become necessary.
- It may be possible to mask objectionable sound with a localized white noise generator.
- Some restaurants and dining facilities provide a vibrant and active atmosphere to reflect a culture of accomplishment. Examples include dining facilities for a college or a business incubator center. Other dining facilities strive for a quiet and intimate setting. Those two very distinct and different end goals obviously require different treatments of walls and ceilings to achieve desired reverberation times. The end goal should be known before acoustic design begins.
- The average noise intensity of a dining establishment during a rush period can fall in the 80-110 decibel range (think road construction). That level of noise can do a lot of damage over time, especially to employees and regular patrons. OSHA has guidelines in place limiting the intensity of sound to which employees and patrons of dining establishments can be exposed. Few restaurants with active environments, comply with these requirements at this point. A few lawsuits will encourage more compliance. We just don't want to participate in those lawsuits.

### Dining Venues: Outdoor Dining

*Use:*

These large spaces provide places where patrons can sit at tables to consume food prepared in nearby restaurants. Activities in these spaces include waiting to be seated or served, patrons being seated, ordering food, transmission of orders to kitchen staff, transportation of prepared food from kitchen to tables, consumption of food, consumption of beverages, conversation at and between tables, possible enjoyment of live or prerecorded music or performances, paying for food by various means, patrons exiting, clean-up of tables and dishes, and resetting of tables. As can readily be imagined, most of these activities generate significant levels of sound. That doesn't even consider exterior sounds entering the outdoor dining area.

*Site Concerns:*

Most people who dine in outdoor environments, expect some noise entering the enclosure from the exterior. If there is a source of high intensity noise nearby, like a train, airport runway, or highway, that will likely need to be blocked, absorbed, or reflected, to some degree.

Almost always, to provide any degree of privacy to such diners, either visual or acoustic, there is a reasonably high enclosure around the perimeter of outdoor dining spaces.

*Intent of Design:*

The intention is to acoustically isolate, to a tolerable level, outdoor dining areas from other noise generated by outdoor sources. Noise generated inside the space must also be controlled enough that the dining experience does not become unpleasant, to patrons attempting conversation.

*Known Acoustic Design Considerations:*

- Locate the outdoor dining area, if possible, in an area where noise from it, will not adversely impact surrounding residential or business uses.
- The more mass contained by the surrounding enclosure, the more kinetic energy coming from surrounding noise generators will be reflected or dissipated.
- The higher the surrounding enclosure, the more kinetic energy coming from surrounding noise generators will be blocked.
- To help acoustically isolate tables from each other, shrubbery or low walls / fencing can separate the outdoor space into smaller and more private areas. Shrubby is usually somewhat ineffective at sound isolation, unless combined with some other barrier like a wall or a berm.
- Sounds that cannot adequately be blocked or absorbed, can be masked. Sources of running water, like fountains, are good sources of white noise. Speakers can also be in various places in outdoor dining areas, to transmit sound from other white noise generators.
- If there is live music, or even prerecorded music played for entertainment, local noise ordinances will have something to say about how much noise can enter surrounding areas from the outdoor dining area.

Common Use Venues: Common Gathering / Multi-use

*Use:*

This large, adaptable space is used, exactly as the name implies, for multiple purposes. This means on any given day, it may be used for dining, assembly, a lecture, a musical performance, or just meeting for conversation.

*Site Concerns:*

Detectable noise entering a gathering space from the exterior, especially during a presentation, is obviously detrimental. If there is a source of noise nearby, block, absorb, or reflect that acoustic energy.

Large expanses of glass, or doorways sufficient to handle large volumes of traffic, are weak spots in the acoustic envelope. It may be necessary to have a secondary sound barrier inside, to further prevent sound transmission into the gathering space.

*Intent of Design:*

The intention is to create a space suitable for both professional and social gathering. The space should allow for intelligible speech, but still enhance the experience of dancing or listening to music. For the first, there must be significant absorption. The second requires enough reflection to create a longer reverberation time. This mix will require careful balance of envelope materials, directional control of various sources of sound waves, an ability to mechanically alter the material composition of the space at will, or a combination of these solutions.

*Known Acoustic Design Considerations:*

- For enhancement of music, while still allowing comprehensible speech, the space should provide a reverberation time between 0.9 - 1.1 seconds.
- Music, and possibly vocal presentation, will sometimes involve minor amplification of sound, usually with a small self-contained system. If the location of speakers is controlled, this will allow directional control of generated sound.
- Ceiling mounted speakers, primarily for use in vocal presentations, will help with comprehensible distribution of speech across the space. This system works better if the floor below, in seating areas, is sound absorbent to reduce potential echoes.
- HVAC systems will need to provide cooling and fresh air to large numbers of potentially active people. Such systems are noisy, certainly enough to disrupt speech comprehension across a large space. Steps will need to be taken to lower system noise to an acceptable level.
- Unless sound is prevented from reflecting off a back wall opposite a platform, the echoes returning to performers or presenters will distract both them and their audience.
- Side walls should be left partially reflective to help increase reverberation time and enhance the presentation of music.
- Curved walls have an undesirable side effect of focusing and intensifying reflected sound.
- Multi-use spaces sound much different when seats are filled, then when the space is only partially occupied.
- Careful attention should be paid to materials used for flooring and where they are used. A hard surface is needed for dancing. This surface will reflect sound further beyond it.
- Ceilings of absorptive materials are needed to lessen reverberation in these spaces.
- Sound moves outward from a platform or stage in an expanding wave. Based on their geometry and the materials used, ceilings will shape and direct sound being produced on stage.
- Larger spaces can be divided by operable walls covered in acoustical material. Special care must be taken to insure operable partitions acoustically isolate one space from another. And once such panels are pulled, acoustic characteristics of spaces on each side will change.

- These spaces will sometimes contain vending machines or televisions. Care should be taken to ensure sound from these, does not enter adjoining spaces.

#### Common Use Venues: Atrium

##### *Use:*

These reasonably large areas, used for entry and exit from buildings, are often acoustical buffers from exterior to interior spaces. Other than the need for speech comprehension inside them, these spaces are not acoustically sensitive. But with high volumes of use, they can be significant generators of noise, and must be somewhat isolated from adjoining spaces.

##### *Site Concerns:*

There are few site concerns with these spaces. By design, they are adjacent to areas of vehicular traffic and usually contain large expanses of glass separating them from the same. It is difficult to significantly isolate them from site noises. Only if there are intense noise sources nearby, are extraordinary measures taken to buffer site noises.

##### *Intent of Design:*

These spaces should be visually inviting, but not overwhelm those who use them with an excessive buildup of noise. Nor should they create acoustic problems for adjoining spaces.

##### *Known Acoustic Design Considerations:*

- These spaces generally have hard or reflective surfaces, especially on floors, and higher than normal ceilings. This combination allows reverberation to build, which if left untreated, will cause problems with speech comprehension. Sound absorbent materials, especially at the ceiling level and on upper walls, should be used.
- Though these spaces tend to be active, and a certain level of noise is accepted, constant users of the space, like receptionists, security guards, bellboys, etc., must be protected from excessive noise.
- Music is not generally an issue in lobbies, nor are they designed with performance enjoyment in mind. Music heard within them, will come through ceiling mounted speakers, via a public-address system.
- There is a lot of speech that takes place in a lobby. Some conversations will need some degree of privacy, especially when of a financial nature. Walls directly behind receptionists and check-in counters should be very acoustically absorbent.

#### Common Use Venues: Hallway

##### *Use:*

These relatively narrow spaces, points of access to primary interior spaces, need to be blocked acoustically from adjoining spaces they serve. On rare occasions, like in educational or church facilities, they can also be significant sources of noise.

##### *Site Concerns:*

There are few site concerns with these spaces, since they are generally in building interiors. If they are on the exterior, and contain large expanses of glass, and there are intense noise sources nearby, then measures can be taken to dampen site sounds.

*Intent of Design:*

These spaces should be visually inviting, with materials and assembly construction used to acoustically isolate them from adjoining spaces.

*Known Acoustic Design Considerations:*

- There are numerous potential gaps in acoustical separation between hallways and adjoining spaces. These include, but are not limited to: return air transfer grilles, sound reflecting through ceilings because partitions do not extend to decks above, gaps below doors, glazing between rooms and hallways, dividing walls that are not insulated, and outlets that create gaps in the insulation when they are. Those gaps should be identified and eliminated.
- Not only is noise from corridors a problem for adjoining spaces, but conversations in those adjoining spaces should not be audible in the hallways. That negates the reasons conversations are held in closed, and theoretically private, rooms.
- In settings where people travel through hallways in large groups, impact noise from bodies brushing up against, or hitting walls of adjoining spaces, can become a problem.
- Upper level corridors, adjoining much higher spaces beside them, will transmit impact noise of footsteps in the hallway, into the adjoining higher space, when structure supporting the hallway is attached directly to walls of the higher space.
- Because they are finished to resist abrasion from users passing through, hallway wall finishes should be durable, and therefore reflective. Primary surfaces to treat for reduced reverberation in hallways are floors and ceilings.

Healthcare Venues: Healthcare Facility

*Use:*

Healthcare facilities house a wide range of activities involving medical treatment and consultation. These include: hospitals, nursing homes, hospice facilities, assisted living facilities, independent living settings, adult day care facilities, wellness centers, and outpatient rehabilitation centers. Treatment can run the gamut from simple exams, and discussion of recommended treatments, to radical life-saving surgeries followed by extensive follow-up treatment and rehabilitation. Most spaces in these facilities, for reasons ranging from legal to humane, require high levels of acoustical separation.

*Site Concerns:*

Detectable noise entering medical facilities from the exterior, will detract from patient comfort and prolong the healing process. Especially if such sounds interfere with a patient's ability to obtain restorative rest. To complicate matters, medical facilities are often located in busy urban areas, where potentially objectionable sounds may be generated at all hours of the day. If there are high intensity noise sources nearby, steps will need to be taken to block, absorb, or reflect that acoustic energy, before it can transmit through the exterior envelope.

*Intent of Design:*

Spaces created for; office functions, treatment, family members dealing with loss, counseling, and other medical activities must be acoustically separated, sometimes within close confines, to maintain dignity, comfort, and confidentiality.

*Known Acoustic Design Considerations:*

- In some medical facilities, noise levels are not suggested, but mandated. For each room in a military facility, an RT60, NC, and STC are specified.
- Published standards for healthcare facilities can be found in the *Sound and Vibration Design Guidelines for Hospital and Healthcare Settings*. These are written to ensure sound isolation and speech privacy of speech that complies with the HIPAA act. These guidelines apply to new construction and renovations of healthcare facilities.
- HIPAA privacy rules dictate that whenever information about patients is being discussed, the sound of that speech must be controlled or absorbed to prevent anyone else from overhearing. This becomes problematic in areas where consultation may occur with multiple patients at one time, like at billing centers. Enclosures around individuals involved will require very highly absorptive treatments. The words of the medical practitioner will need to also be captured, so it will not be overheard by others behind or near the patient.
- Sound between common areas and patient rooms can be transmitted through dividing walls, common ceiling plenums, and open doors.
- Such sounds can originate from; patient-care equipment, emergency alarms, other monitoring equipment, service carts, intercom systems, patient/doctor discussions, family visits, and HVAC systems.
- Wall assemblies around areas, where confidential patient information is discussed, should not only be absorptive, but those assemblies should extend all the way to the deck.
- Recommended noise levels for patient areas during the day is 35 db(A). That is difficult to achieve, since most hospitals test at 45-50 db(A). Noise level in common areas is higher than normal conversation levels, and must be kept from reaching patients at that level.
- Constant noise in areas like nurse's stations; voices, machine sounds, and traffic sounds, make recuperative rest difficult in rooms where sound is easily transmitted. It increases stress levels on patients already stressed. While patient areas, due to concerns with sterility, typically use hard reflective surfaces, necessarily centralized nursing areas can be surrounded with more absorbent finishes, reducing one major source of noise at its origin. This results in a nicer working environment for the staff, and fewer mistakes resulting from misunderstood or missed communications. Where these stations can be more isolated from patient rooms, while still maintaining function, they should be.
- The other primary method to combat acoustic discomfort to patients, is to eliminate all possible gaps or weak spots through which noise can easily transfer.
- Absorptive materials used as interior surface finishes and underlayments, isolation membranes, and gaskets to reduce sound transmission, can be used to control sound. Because of sanitation requirements, carpet is almost never used on floors.
- Measures to reduce HVAC noises should be included in the budget.
- The quality of windows should be upgraded, especially in patient rooms, using insulated glass and acoustically separated frames, to help resist transmission of exterior noises.
- Expansion joints and transitions between floor surfaces cause additional noise to be generated by rolling equipment passing over them. Try to create smooth, continuous, cleanable floor surfaces.

Healthcare Venues: MRI Suite

*Use:*

These spaces house MRI machines, used for patient diagnosis. The equipment in MRI suites generates a high level of sound and will require high levels of acoustical separation.

*Site Concerns:*

Site noise can be of concern in these suites. Since windows are increasingly incorporated, to help reduce claustrophobia induced by the diagnostic process, high intensity noise sources on site are problematic. Steps will need to be taken to block, absorb, or reflect that acoustic energy before it can get to the exterior envelope.

*Intent of Design:*

Spaces created for MRI suites should reduce the transmission of noises from the process to adjoining areas, and absorb the same sounds, as much as possible, within the patient and exam areas.

*Known Acoustic Design Considerations:*

- As a rule, MRI machines generate a lot of noise. It is harmful and stressful to patients and can be very harmful to staff who operate the machinery all day long. Patients in nearby rooms don't want to hear it either. Spaces housing these machines should be created from assemblies that are highly acoustically absorptive.
- Staff who operate machinery should be protected from the noise. Their enclosure should not only have absorptive walls and ceilings, but also doors and observation windows with high STC ratings.
- Wall and floor assemblies forming these spaces should be acoustically isolated from surrounding spaces if possible. This will reduce structure borne sounds from machine vibrations. Methods and materials, used to attach isolated assemblies, must be carefully chosen. If they are of the wrong materials, they can interfere with the magnetic field used for imaging.

Work Venues: Office

*Use:*

These spaces are created to house certain business-related functions. These include; research and studying, generating reports, making telephone calls, meeting and conferencing both inside and outside of rooms designed for the same, and some degree of social interaction with colleagues. All these activities generate noise that should be minimized.

*Site Concerns:*

Detectable noise entering an office environment from the exterior, especially during a presentation, is obviously detrimental. If there is a source of noise nearby, block, absorb, or reflect that acoustic energy.

Large expanses of glass, or doorways sufficient to handle large volumes of traffic, are weak spots in the acoustic envelope. It may be necessary to have a secondary sound barrier inside, to further prevent sound transmission into the office space.

*Intent of Design:*

Spaces created for office use should minimize as much noise as possible, both from internal and external sources, to maximize the ability of users to focus on work.

### *Known Acoustic Design Considerations:*

- For clarity of speech and enhanced productivity, in private offices, the recommended reverberation time is between 0.6 - 1.0 seconds. In open office layouts, an acceptable reverberation time is 0.75 seconds.
- Ignoring acoustic problems in offices carries a special price tag. Research has documented that the single most important factor in individual and team performance, reducing stress, and increasing job satisfaction, is an ability to work without distraction. The most powerful distraction in today's office environments is unwanted noise. Stress, generated by trying to mentally block out distracting noise, has a direct consequence on worker health, leading to higher rates of absence.
- Sources of noise in offices include telephones ringing, telephone conversations, speakers on telephones, electronic device notification sounds, intercom systems, structure borne sounds such as footsteps, HVAC system sounds, office machinery sounds, nearby conversations, and exterior noises.
- If possible, copiers should be placed in separate spaces, away from open office environments and spaces sensitive to sound.
- HVAC sounds can be lessened as described earlier.
- Internal noise generation can be controlled by highly absorbent acoustic treatment of office envelopes. Walls that do not go all the way to the ceiling, such as office landscape partitions and panels, need to be especially so. Ceilings will need to be acoustically absorptive.
- Walls around areas where sensitive information is divulged, and where undesirable noise is generated, should contain additional absorbent materials such as sound insulation, and must extend all the way to the deck above to stop transmission through a shared plenum. If this wall extension is not feasible, then a sound barrier of insulation should be installed above each ceiling.
- Since natural light is also important to productivity, windows are usually a component of the envelope surrounding office space. If there are objectionable sources of noise in proximity, higher grade glazing should be used and entry systems should include vestibules.
- Mind the gaps in an envelope created for acoustic privacy. Sound can travel between rooms via ductwork. It can enter from corridors through spaces under doors. Outlets placed back to back create holes in the sound insulation in a wall. Single pane glazing in a hallway is an excellent diaphragm to transmit any sound striking it from one side to another.
- In spaces where groups meet, it is important that speech comprehension be at a high level. At least one of each set of parallel walls should be treated to absorb sound and reduce reverberation time. A reflective finish on the ceiling above a conference table can help direct sound to attendees at a far end of a table. But the rest of the ceiling should be highly absorptive to trap kinetic energy of the sound and prevent echoes. Carpet will also play a role in reducing sound in such spaces.
- In more open spaces, such as break rooms or open office 'bullpens,' acoustical separation will be needed between these and adjacent private offices. Besides other options mentioned, suspended sound absorbent 'clouds' can help prevent a buildup of sound in areas with higher ceilings, before it reaches problem levels.
- Open areas for multiple users are often incorporated in office environments to: primarily save on cost, maximize the use of expensive floor space, allow easy reconfiguration, increase interaction between workers and management, and facilitate team projects. This configuration can also result in excessive noise generation and worker distraction.
- Employees typically spend about twenty-five percent of their day in conversations, either in their workspaces or those of others. Dividing partitions in open office areas are not typically full height, but should be high enough to block direct transmission of speech from workers outside partitions, to those seated on the other side. This requires a minimum partition height of 60," with sound absorbing material on each side.

- When possible, place full height partitions to prevent direct sound paths from one cubicle to another. Then control the reflection of that same sound off nearby walls, so the partition placement does not become ineffective.
- Lighting fixtures placed directly over cubicle walls can bounce sound from one cubicle, down into an adjacent cubicle.
- White noise, or sound masking, is increasingly utilized to help users concentrate in office environments. These provide an electronically generated, ambient background noise, delivered through speakers mounted above ceilings. When done correctly, workers quickly become unaware of sound used for masking, while finding other noises to be far less intrusive. Essentially, the sound masking creates less of a decibel difference between normally intrusive noises and the sound used for masking, making otherwise intrusive noises less noticeable.
- This concept works if the masking noise is not, in and of itself, loud or intrusive enough to become annoying. Since different spaces employ different acoustic treatments, if a white noise generator serves separate spaces with differing uses, a way to control the level of the masking sound should be provided for each.
- Especially in large open areas, given annoying echoes that can be produced by parallel walls, at least one wall of each parallel pair should be treated with sound absorbing materials.
- Draperies over windows cannot be counted upon to absorb any sound, since there is no way to ensure they will remain closed.
- How much sound transfers between spaces will be determined by the weakest link in the barrier between them, especially air gaps. It is hard to block all sound, but when speech from one space can be understood in another, it is very distracting. Not to mention, privacy becomes a moot point.
- What is an acceptable noise level for one type of business or space, may not be acceptable in another. Acceptability varies based on the need for confidentiality, sensitivity of the workers and the expected level of privacy. It is important to learn, and then strive to meet, expectations of specific users for spaces being designed.
- Ducted air systems, rather than those which use common plenums, are a good way to help eliminate that common gap in sound isolation where privacy is important. Especially a ducted air return system, rather than a common plenum.
- Avoid locating mechanical equipment rooms next to offices and conference rooms.

### Work Venues: Home Office

#### *Use:*

These spaces are created for users performing certain business-related functions from their homes. These include, research and studying, generating reports, making telephone calls, and remote conferencing. All of which create noise that should be somewhat contained.

#### *Site Concerns:*

Detectable noise entering from the exterior, during work hours, will be detrimental to the purpose for which the space is constructed. This will require focusing on the STC rating and sound isolation qualities of the materials or assemblies of that envelope.

If there are weak spots (gaps) in an otherwise sound resistant envelope, like large expanses of glass or doorways that don't seal well, steps will need to be taken to reduce the amount of noise being transmitted.

#### *Intent of Design:*

Spaces created for home office use should minimize as much noise as possible, both from internal and external sources, to maximize the ability of users to focus on work. They should also contain noise generated from within, to prevent it from disrupting other activities in the home.

*Known Acoustic Design Considerations:*

- Most noise transmitted between a home and home office, will be transmitted through the doorway into the office. Use weather stripping and a drop seal on the door to improve sound isolation.
- HVAC noises, unless addressed during the design phase, will be distracting during phone calls and conversations when the system turns on and shuts off.
- At least one wall of each parallel pair should be treated with sound absorbing materials.
- Don't place functions that will generate structure borne sound, above or below home offices. Don't locate them directly adjoining home offices either. Recreation rooms don't work well next to home offices.

Education Venues: Classroom

*Use:*

These small spaces are used for vocal presentations, usually informational in nature. Most will also utilize multi-media presentations, but even these will primarily involve speech, rather than music. There should be a minimum of distractions created by the acoustics of the space. Such distractions make it very difficult for young students with a poor grasp of language, students who are hearing impaired, and those with English as a second language, to learn much.

*Site Concerns:*

Since these types of spaces are often located on exterior walls, having significant glazing to allow in natural light, any noise striking the wall and windows from nearby site noise generators, will be a problem. It will need to be reflected, blocked, or absorbed.

*Intent of Design:*

The intention is to minimize outside noises and create quiet (below 40 dBA) educational spaces. These will allow for intelligible speech and audiovisual presentations. To optimize the primary use of these spaces, there must be significant absorption to control internal noise, as well as dampening of sounds entering from HVAC systems, the exterior, and adjacent spaces.

*Known Acoustic Design Considerations:*

- For clarity of speech and enhanced productivity, reverberation time for spaces containing over 10,000 cubic feet is recommended to be between 0.4 - 0.6 seconds. Between 10,000 - 20,000 cubic feet, the maximum reverberation time can extend to 0.7 seconds. Reverberation time is largely controlled by absorbent materials and assemblies.
- In spaces containing less than 20,000 cubic feet, one-hour steady-state background noise levels should not exceed 35 dBA. Spaces larger than this should not exceed 40 dBA in background noise levels.
- Locate buildings containing classrooms, as far as possible from busy roads and other sources of site noises.
- Use better grade windows and exterior wall assemblies, designed to block and absorb unavoidable noise from the exterior.

- The best acoustical design for schools, having many spaces serving different functions, is to keep those different functions as acoustically separate from each other as possible.
- The best approach is to design each educational space for speech comprehension, using acoustically appropriate systems and materials in each space. Then focus on preventing interior and exterior noises from entering those quiet spaces.
- Don't locate mechanical rooms, toilets, music practice areas, dining areas, gyms, or any other noisy spaces, adjacent to classrooms or other centers of learning.
- In multistory educational buildings, use quality acoustic underlayment beneath flooring and rated ceilings on resilient channels as part of floor-to-ceiling assemblies. Carpet on the floors will also help absorb energy from footfalls.
- Keep class sizes smaller than 1,500 square feet. Classrooms larger than that, reverberate longer than 1.0 second, lowering speech comprehension. Studies indicate that students only hear seventy-five percent of what is said anyway. We don't want to lower that even more.
- Even in smaller classrooms, sound absorbing finishes on at least one of each set of parallel walls will help with reverberation.
- The best HVAC units for educational use, are rooftop units with central ventilation systems and quiet ducting, with the actual rooftop units located away from classrooms and learning centers.
- Walls around classrooms and learning centers should extend to the deck above to stop transmission through a shared plenum. If this wall extension is not feasible, a sound barrier, like ceiling insulation, should be installed above each ceiling.
- Hallways are huge generators of noise as students pass between classes. Special care should be taken to acoustically isolate these from classrooms and learning centers.
- Don't create open learning environments, where classrooms are hardly separated from one another. These designs sound great in concept, but have proven to be disastrous in terms of student comprehension and performance. When normal conversation occurs at a level of around 63 dBA, and readings in open classroom environments during relatively quiet times range from 55-80 dBA, the problem becomes immediately apparent.
- Because of the research showing loss of student performance due to poor acoustics, criteria for acoustic benchmarks in educational facilities will soon be a part of building codes. Meeting these will require knowledge of acoustic principles and mathematics to determine compliance.
- Background system noise levels in a space, will include noise from HVAC units, electrical fixtures, light fixtures, and plumbing systems.
- Light fixtures with low noise ballasts are recommended for learning areas.
- Ways to minimize plumbing system noises include; locating restrooms away from classrooms, not running piping above learning spaces, using cast iron waste water pipes when possible, and resiliently isolating all water piping from the structure.
- HVAC system noise levels are impacted by; selection of grilles and diffusers, airflow velocities, and duct lining.
- Specific sound transmission class (STC) ratings for separating core learning spaces from adjacent spaces, will soon be specified for single or composite walls, floor-ceiling and roof-ceiling assemblies. Obviously, none of these are attainable in open plan concepts. Here are some suggested (for now) STC ratings, between classrooms and other spaces.
  - Corridor, staircase, office or conference room - STC-45
  - Another learning space, speech clinic, health care room or outdoors – STC-50
  - Restroom – STC-53
  - Music room, mechanical room, cafeteria, gym or indoor pool – STC-60
  - Classroom doors - STC-30
  - Music room doors – STC-40
- The number and location of penetrations through a wall, as well as the number and location of electrical outlets, becomes important in limiting sound transfer through gaps. Electrical outlets to

opposite rooms, in single width stud walls, should not be placed in the same stud space, and especially not back to back.

- Seal all joints and penetration through dividing walls.
- It is becoming increasingly unlikely that single width stud construction will meet required STC ratings. Separation walls will most likely require staggered or dual stud construction and/or multiple layers of drywall.
- In multi-level facilities, areas that generate impact noises, such as dance studios or gymnasiums, should not be located above learning areas.
- Any vibrating equipment, such as HVAC units, when placed on rooftops or mechanical rooms above other spaces, should be mounted on rubber isolation pads or spring systems to lessen transfer of kinetic energy through the structure and beyond.
- Classroom doors should not be aligned with each other across corridors. Staggering door locations will help inhibit noise transmission.

### Education Venues: Library

#### *Use:*

These large spaces are used for research and studying. Most will have smaller spaces that will rarely involve performance or multi-media presentations, but even these will primarily utilize speech. But in all these spaces, there should be a minimum of acoustic distractions. These decrease the learning potential of all users of these spaces.

#### *Site Concerns:*

Since these types of spaces are often located on exterior walls, having significant glazing to allow in natural light, any noise striking the wall and windows from nearby site noise generators, will be a problem. It will need to be reflected, blocked, or absorbed.

#### *Intent of Design:*

The intention is to minimize outside noises and create quiet (below 40 dBA) educational spaces. These will allow for intelligible speech and audiovisual presentations. To optimize the primary use of these spaces, there must be significant absorption to control internal noise, as well as dampening of sounds entering from HVAC systems, the exterior, and adjacent spaces.

#### *Known Acoustic Design Considerations:*

- For clarity of speech and enhanced productivity, reverberation time for libraries should be no more than 0.8 - 1.0 seconds.
- Most of the recommendations, listed above for classrooms, apply here as well.
- If domes, vaults, or concave surfaces are part of the ceiling design, steps must be taken to ensure these do not focus sound downward in unacceptably intense levels.
- Acoustically separate any activity areas from quiet areas for study

### Fitness Venues: Gym

#### *Use:*

These large spaces are primarily used for playing indoor sports. Occasionally, they will also be used for assembly purposes, in conjunction with education, worship, or community functions.

### *Site Concerns:*

Detectable noise entering the space from the exterior, especially during a speech, would obviously be detrimental. If there is a source of noise nearby, especially one of high intensity, steps will need to be taken to block, absorb, or reflect that acoustic energy. Other than those, few considerations are typically given to isolating gymnasiums from site noise.

### *Intent of Design:*

The goal here is to take a typically noisy space, due to the required durability of inside surfaces, and make it somewhat usable for other functions.

### *Known Acoustic Design Considerations:*

- The usually parallel hard surfaces, that resist damage from balls striking them, also cause a tremendous buildup of reverberation and noise. Absorptive materials will be needed to help control this. These are often placed on lower portions of walls, to also help cushion human impact during games. Sometimes the underside of roof or floor decks above is treated with acoustic materials. Floors are rarely anything but a hard surface.
- If used only for gymnasium activities, reverberation time in these spaces needs to be below 2.0 seconds. If speech will be a part of other uses for the space, a reverberation time of 1.0 - 1.5 seconds is the goal. Reverberation times of over 2.0 seconds are unacceptable for any use.
- Acoustic treatments in a gymnasium must still be very durable.
- When being used for functions involving speech, chairs covered with sound absorbent padding, will help reduce reverberation time.
- Noise from a gymnasium will be problematic for adjacent spaces. Steps must be taken to absorb or block that sound. Walls must go all the way up and seal to the deck above. Having significant mass in the walls, to absorb kinetic energy, will help. The best sound isolation practice is to enclose the space with two separate walls, so structure borne sound of balls hitting walls does not transfer.
- The best way to reduce transfer of noise from gymnasiums to spaces which require low sound levels, is to make sure gymnasiums are not located adjacent to acoustically sensitive spaces.

### Multi-family Venues: Hotel

#### *Use:*

These spaces are primarily created for paying guests to rest and relax, to study and work, but most often to sleep. Other functions found therein include; moderate dining facilities, modest recreational and exercise facilities, and sometimes conference or small convention rooms. Most of these functions also require some acoustic isolation.

#### *Site Concerns:*

Detectable noise entering from the exterior, will obviously be detrimental to customers expecting to sleep. If there is a source of noise nearby, especially one of high intensity like a train, airport runway, or highway, steps will need to be taken to block, absorb, or reflect that acoustic energy before it can transmit through the exterior envelope. It may require some pre-planning on what direction windows face.

Large expanses of glass, or doorways sufficient to handle large volumes of traffic, are weak spots in the acoustic envelope. It may be necessary to have a secondary sound barrier inside, to further prevent sound transmission into hotel rooms. Higher grade windows may also become necessary

*Intent of Design:*

The intention is to create spaces for guest privacy and comfort that are as quiet as possible. Other spaces ancillary to primary guest functions, must be isolated so noise from these will not negatively impact guests in their rooms. This requires control of noise from other guest rooms, corridors, and mechanical equipment.

*Known Acoustic Design Considerations:*

- Two primary acoustic issues must be addressed in a hotel environment. These are air borne sounds, like televisions and speech, and structure borne sounds, like footsteps and objects being set down.
- Space planning can eliminate acoustic conflicts before they become problems. Don't place noisy functions next to acoustically sensitive spaces. Vertically stack spaces like ice machine and laundry rooms, so they do not wind up over guest rooms.
- There are sound isolation requirements between hotel rooms, already stated in building codes. These are rarely enforced at this point, but they are law. They require floor to ceiling assemblies, and wall assemblies between rooms, to have a minimum STC rating of 50. Floor to ceiling assemblies are required to have an Impact Insulation Class rating of 50.
- Artwork or headboards, mounted directly to dividing walls, will greatly reduce sound isolation, unless those walls are double walls with air space between them, or of staggered stud construction.
- Air gaps and penetrations between rooms and corridors should be sealed with an acoustic sealant. This includes perimeters of the walls. Back to back outlets or switches should be avoided, and outlet and switch boxes should have a sound absorption pad behind them.
- Noise coming through entry doors from corridors is a major annoyance in hotel rooms, but one that can be controlled. Doors to corridors should have a minimum STC rating of 26, with drop seals that come down to thresholds, rather than down to carpet.
- Isolate elevator shafts, and their structural components, from the rest of the building structure. Otherwise, structure borne noise from their operation will transfer through the building and into rooms.
- Plumbing pipes should be attached with resilient mounts, isolating them from their supporting structure, to reduce structure borne sound from these. Pipes should also be wrapped with pipe insulation.
- Roof mounted equipment should be supported on springs or isolation pads and not located above guest rooms.
- Exterior noise can be transmitted into rooms through glazing and through PTAC HVAC units. These both will need upgrading to a higher quality, if there is a troublesome source of exterior noise nearby in line with guest room windows.
- Most PTAC units produce significant noise, when in operation. There is a potential for this noise to be used for sound masking, if fans are set to run continuously, rather than just on demand for temperature regulation.

Multi-family Venues: Multi-family Housing

*Use:*

These spaces are living quarters, for all facets of life, including sleep. Other functions supported thereby include; dining, modest recreation and exercise, and entertainment.

*Site Concerns:*

Objectionable noise entering from outside will obviously be detrimental to some functions in a home. Steps will need to be taken to block, absorb, or reflect such exterior noises.

If there are weak spots (gaps) in an otherwise sound resistant envelope, entry vestibules and better windows may become necessary.

*Intent of Design:*

The intention is to create living quarters that are as quiet as possible. Other spaces, ancillary to living quarters, must be isolated so noise from them will not impact homes. Minimizing noises from other living quarters, corridors, and mechanical equipment will also become important.

*Known Acoustic Design Considerations:*

- Acoustic concerns for multi-family housing are nearly identical to those for hotels.
- While a great deal can be done to alleviate sound transfer, it is virtually impossible to completely block sound transfer between units. The cost is just too prohibitive to be recouped by market competitive rent structures.
- Most noise entering one unit, will depend largely on what is happening in units surrounding it. Such noise will be most noticeable in spaces, like sleeping quarters, that have no sound being generated within them to mask other noise.
- As in hotels, potential acoustic problems can be avoided by duplicating layouts vertically. That way, kitchens and bathrooms wind up over kitchens and bathrooms, rather than over bedrooms.
- Hard surface flooring in living units creates far more structure borne sound than carpeted surfaces. The trend toward tile and wood flooring to increase marketability, means that sound isolation in floor to ceiling assemblies becomes an important part of acoustic design in multi-family venues. The section on design suggestions to alleviate vertical sound transmissions, offers a few practical strategies.
- Guidelines drafted by HUD set nighttime dBA levels for sound transfer between units, that vary based on classification of units as luxury, average, or minimum grade housing.

Worship Venues – Churches

*Use:*

This building will contain at least one significantly large space, used for worship involving vocal presentations or music performance. What gets especially complicated, is when a single service alternates between these two types of sound, repeatedly, in the same service.

*Site Concerns:*

Detectable noise entering from the exterior, during a service, would obviously be detrimental to the purpose for which the space was constructed. If there is a source of noise nearby, especially one of high intensity like a train, airport runway, or highway, it will need to be blocked, absorbed, or reflected

If there are weak spots (gaps) in an otherwise sound resistant envelope, like large expanses of glass or doorways sufficient to handle large volumes of traffic, it may be necessary to have a secondary sound barrier inside to further prevent sound transmission into the space.

#### *Intent of Design:*

The intention is to create worship space allowing for intelligible speech, while enhancing listening to music and singing. For the first, there must be significant absorption. The second requires enough reflection to create a longer reverberation time. This mix will require careful balance, directional control of the sound waves of each presentation type, an ability to mechanically alter the material composition of the space at will, or a combination of these solutions.

#### *Known Acoustic Design Considerations:*

- For enhancement of music, while still allowing comprehensible speech, the space should provide a reverberation time between 0.9 - 1.1 seconds.
- Music, and possibly vocal presentations in these spaces, will usually involve amplification of the sound. If speaker locations are controlled, this will allow for directional control of generated sound. One seemingly obvious, but rarely used solution for reducing reverberation time, involves directional control. This is the use of one set of microphones and speakers for speech, and another set for music. Speakers for music are set low and aimed high, to reverberate against hard ceiling surfaces, increasing resonance of the music. Speakers for speech are set high and aimed toward a floor with absorptive flooring material and upholstered seating, to kill reverberation. Microphones are color coded for each use. The obvious drawback is cost of second sets of microphones and speakers. That cost might be less expensive than wall materials with changeable surfaces, mechanical or otherwise.
- Ceiling mounted speakers, primarily used in vocal presentations, work better if the floor below in seating areas, is sound absorbent to reduce potential echoes.
- Unless sound is prevented from reflecting off a back wall opposite a platform, bounce back returning to performers or presenters will be distracting to them and their audience.
- Side walls should be left somewhat reflective to help increase reverberation time and enhance the presentation of music.
- Curved walls have an undesirable side effect of focusing and intensifying reflected sound.
- If not taken into consideration during design, worship spaces sound much different when seats are filled, then when space is partially occupied.
- Ceilings of absorptive materials are needed to dampen reverberation in these spaces.
- Strategically placed “clouds” of acoustic absorbing material can be used at or below ceiling levels, to dampen unwanted sound from reflecting down in certain directions.
- Sound moves outward from a platform or stage in an expanding wave. Based on their geometry and the materials used, ceilings will shape and direct sound being produced on stage.
- Mounting speakers higher than seating will help in better dispersion of sound to the audience.
- The easiest way to eliminate acoustic problems due to sound transfer, is to not place areas generating excessive noise next to spaces that need acoustic privacy. Youth rooms or gymnasiums should not be placed next to auditoriums, if both will be in operation simultaneously.
- The best way to isolate auditoriums from adjacent classrooms and lobbies, is to have a corridor or some other space between them.
- It is also very effective to acoustically isolate the primary worship space with double walls physically separated by an air space.

- HVAC systems that supply cooling and fresh air to large numbers of people will be noisy. They will disrupt services, if steps are not taken to lower system noise to an acceptable level. This is especially critical in spaces used primarily for vocal presentations.
- Reverberation time on the platform should be approximately the same as within the audience area. Steps must be taken to equalize reverberation times between the two areas.
- Sound will enter from the lobby area, along with parishioners leaving and returning to their seats. Doors that seal very well can help with this, but an airlock or vestibule between the lobby and each entry is even more effective.
- As discussed earlier, noise entering an auditorium through walls from adjoining spaces can be abated in several ways.
- Parallel surfaces will allow sound echo, wreaking havoc with speech comprehension.
- Overhanging elements like balconies, or ceilings enclosing lower adjacent portions of an auditorium, will distort sound waves coming to people in the space below them.
- Panels with absorptive material on one face and reflective on the other, that can be rotated or changed quickly, can be used to alter reverberation characteristics of an auditorium. This is interesting and tempting technology that seems to solve the problem of mixing sound types, but it can be disastrous if technology used to make the change goes wrong.
- An older version of the solution mentioned above is to use wall surfaces that are reflective for music, that can be covered with drapes or acoustic panels for other presentations.
- Having a performance area higher than the seating will help in better dispersion of sound to the congregation.
- Classroom or fellowship halls can be divided by operable walls covered in acoustical material. Unless they have high STC ratings, seal to the floor, and hang from bulkheads containing framing and sound insulation extending to a deck above, performance of these operable partitions will likely be disappointing. Without the abovementioned precautions and enhancements, operable partitions will not adequately acoustically isolate one space from another. And once such panels are pulled, acoustic characteristics of spaces on each side will change.
- Control booths for sound amplification systems should be slightly higher than seating, so visual contact can be maintained with the platform. They should be in the same area as the seating, and not under any overhanging elements. Sound system operators should be hearing exactly what the audience is hearing.

### Review Questions

13. Sound will enter from the lobby area, along with patrons leaving and returning to their seats. The best way to help with this is \_\_\_\_\_.
  - a. Discouraging patron movement during performances
  - b. An airlock or vestibule between the lobby and each entry
  - c. Hanging plastic strips to seal off each entry
  - d. A white noise generator in the lobby
14. Geometric ceilings, like domes, barrels, or vaulted ceiling areas, will result in \_\_\_\_\_.
  - a. Focused noise
  - b. Increased reverberation times
  - c. Lost clarity as sound energy dissipates
  - d. None of the above

15. It is virtually impossible to completely block sound transfer between residential units due to \_\_\_\_\_ .
- Inability to enforce noise abatement rules
  - Higher frequency of children's voices
  - Sound transfer via impact noise
  - Prohibitive expense
16. The best way to isolate auditoriums from adjacent classrooms and lobbies is to \_\_\_\_\_ .
- Use adjacent spaces for classes producing the least noise
  - Use staggered stud construction in separating walls
  - Build corridors between them and other uses
  - Install white noise generators facing outward into adjacent spaces

### **Codes and Testing**

In keeping with increasing concerns and sensitivity regarding acoustics in built environments, a confusing array of codes and standardized testing have materialized to provide either “guidance” or compliance. Most designers just find them confusing.

Most such guidelines are merely suggestions. But for a few building types, acoustic performance is being mandated, especially regarding noise absorption, blocking, and isolation. The following areas are typically addressed in such guidelines.

- Minimizing noise from building systems, like HVAC, electrical, fire protection, and plumbing equipment
- Maximum allowable reverberation times, or minimum NRC ratings
- Controlling transmission of exterior noise into the buildings
- Controlling transmission of interior sounds from space to space.

The following list of codes, standards, guidelines, and building rating systems is probably not all inclusive. Some are very specific to building type.

- Numerous agencies contribute to acoustic guidelines that are applicable to all building types. These agencies include; the Institute of Noise Control Engineering (INCE), the American National Standards Institute (ANSI), the Acoustical Society of America (ASA), the National Council of Acoustical Consultants (NCAC), the Leadership in Energy and Environmental Design (LEED), and the Facility Guidelines Institute (FGI).

#### Applicable to All Building Types

- OSHA - standards for occupational noise exposure, to prevent hearing loss and protect employees from excessive noise in the workplace. Such things as hearing protection at certain noise levels, and limiting time exposure to certain noise levels, are covered. These are enforced at state levels
- International Building Code (IBC) - the only noise requirement listed in the current IBC is a STC/IIC stipulation for Group-R occupancies. Enforcement is by city, county or state agencies.
- National Building Code of Canada (NBC) 1995
- Fundamentals Handbook, Chapter 7, Sound and Vibration, from the American Society of Heating, Refrigeration, and Air-Conditioning Engineers (ASHRAE)
- ASHRAE HVAC Applications Handbook, Chapter 47, Sound and Vibration Control
- 01 57 19.12 (01353) Noise and Acoustic Management, Federal Guide for Green Construction Specs

- DG 1110-3-122 Design Guide for Interiors (Acoustics, p.5.5), from the National Institute of Building Sciences
- NIH Criteria - References Material for the Design Policy and Guidelines, from the National Institute of Building Sciences

#### Applicable to Schools

- Green Globes, from the Green Building Initiative (GBI)
- v4, from Leadership in Energy and Environmental Design (LEED)
- S12.60 Classroom Acoustics, from the American National Standards Institute (ANSI) /Acoustical Society of America (ASA)
- National Core Criteria 2013, from the Collaborative for High Performing Schools (CHPS)
- S12.60-2002, "Acoustical Performance Criteria, Design Requirements and Guidelines for Schools." – introduced by the American National Standards Institute (ANSI), focusing on noise isolation in educational facilities.
- TM 5-803-2/P-970/AFM 19-10 Environmental Protection Planning in the Noise Environment - guidance for selecting sites for new facilities within existing or expected future noise environments
- UFGS 09 51 00 Acoustical Ceilings, from the Unified Facilities Guide Specifications
- UFGS 09 83 13 Acoustical Wall Treatment, from the Unified Facilities Guide Specifications
- UFGS 10 22 26.13 Accordion Folding Partitions, from the Unified Facilities Guide Specifications
- UFGS 10 22 26.33 Folding Panel Partitions, from the Unified Facilities Guide Specifications
- UFGS 10 22 26.43 Sliding Partitions, from the Unified Facilities Guide Specifications
- UFC 3-450-01 Design: Noise and Vibration Control, from the Unified Facilities Criteria

#### Applicable to Health Care

- v4, from Leadership in Energy and Environmental Design (LEED)
- Guidelines, from the Facility Guidelines Institute (FGI)
- Evidence-Based Design (EBD), from the Center for Health Design
- Green Globes, from the Green Building Initiative (GBI)

#### Applicable to Offices

- The WELL Building Standard, from the International WELL Building Institute
- v4, from Leadership in Energy and Environmental Design (LEED)
- E 1374 Standard Guide for Open Office Acoustics and Applicable ASTM Standards, from the American Society for Testing and Materials (ASTM)
- E33.02 Open office acoustics. White Paper. ASTM Standardization News, 26 (12), 39-47, from the American Society for Testing and Materials (ASTM)

#### Applicable to Outdoor Noise Guidelines

- Federal Highway Administration Noise Standard (FHWA)
- Outdoor Codes: Numerous municipalities and other agencies' codes stipulate noise level limits, measured in decibels, with limits varying from city to city.

### **In Summation**

Uncontrolled noise in our built environments, has the effect of negating purposes for which they were built, and harming the occupants thereof. As more becomes known about effects of noise on health, performance, and productivity, more attention is being focused on acoustics.

Fortunately, as we learn more about the problems, we are also developing better and better ways to combat noise transfer from exterior to interior space, from interior space to interior space, and control noise generated within the spaces we design. And it is becoming imperative that we learn quickly.

At this point in time, the only thing certain about upcoming requirements for acoustic criteria in building design, is that there will be upcoming requirements for building acoustics criteria. And in very short order, they will not be suggestions, but enforceable standards which must be met.

At that point, knowledge of acoustics will also cease to be optional, and a rudimentary knowledge of basic sound principles, will become more valuable than ever before.

## Answers to Review Questions

1. When a sound is prolonged by reverberation, that is defined as \_\_\_\_\_ .
  - a. Ricochet
  - b. Amplification
  - c. **Resonance**
  - d. Cacophony

*Answer is C: Resonance is usually beneficial to the perception and enjoyment of music being produced.*

2. An example of sound produced in one basic frequency is \_\_\_\_\_ , while an example of sound produced in multiple frequencies is \_\_\_\_\_ .
  - a. **Voice, Music**
  - b. Heartbeat, Traffic
  - c. Soloist, Choir
  - d. Guitar String, Orchestra

*Answer is A: Since materials react differently to different frequencies of sound, it is more difficult to design for music than for voice*

3. Passive ways to control sound involve \_\_\_\_\_ .
  - a. Changing the volume of a space
  - b. Changing the geometry of a space
  - c. Changing the materials used to define a space
  - d. **All of the above**

*Answer is D: It is amazing how shaping a space can direct the behavior and absorption of kinetic energy, even aiming it at materials designed to absorb or reflect it*

4. One place where a 10-decibel level of sound from an HVAC system will create problems is a \_\_\_\_\_ .
  - a. Rock concert
  - b. Memorial chapel
  - c. Office environment
  - d. **Sound studio**

*Answer is D: In a rock concert, a 10-decibel sound isn't even noticeable. But the goal of a sound studio is absolute sound isolation*

5. STC ratings are determined by \_\_\_\_\_ .
- Sound meters following construction
  - Laboratory testing**
  - Material thickness
  - Averaging listener responses

*Answer is B: Laboratory testing - A sound source is placed in one space and a receiving microphone placed on the other side of the assembly to be tested. Measurements are taken on the far side of the assembly in specified frequency bands, to determine how much of the source sound was blocked or absorbed.*

6. Reverberation time increases in a space when \_\_\_\_\_ .
- Reflective surfaces are added**
  - Absorptive surfaces are added
  - Children are using the space
  - The volume of the space is decreased

*Answer is A: The more surfaces kinetic energy can reflect from with being significantly diminished, the longer it will move through the space and remain audible*

7. Articulation Class rates the amount of sound passing over the top of \_\_\_\_\_ .
- Hedges and shrubs
  - Office partitions**
  - Conference room ceilings
  - Sound baffles

*Answer is B: This class designation was created in response to open office designs and as a way to measure their attendant noise issues*

8. Energy coming into a sound system is typically channeled through a device to \_\_\_\_\_ .
- Amplify it**
  - Split and redirect it
  - Changes its frequency
  - Add resonance

*Answer is A: The primary purpose of sound systems is amplification*

9. Using dense screens of evergreen vegetation to help dissipate and absorb kinetic force of sound waves is generally considered \_\_\_\_\_ .
- A LEED certified solution
  - Not highly effective**
  - A best practices solution
  - Completely useless

*Answer is B: They are attractive, but accomplish less noise reduction than most would imagine*

10. Acoustic barriers from tops of walls to decks above need only be placed \_\_\_\_\_ .
- Between a space and other spaces generating noises**
  - Above light fixtures which penetrate ceilings
  - Above windows between those spaces and adjacent hallways
  - Around the entire perimeter of the space to be protected

*Answer is A: These are put in place specifically because of nearby sources of noise that will interfere with the desired use of the space installing the barriers*

11. Baffles that rotate behind screens, containing absorptive material on one side and reflective material on the other, are sometimes utilized to \_\_\_\_\_ .
- Change the frequencies of sound striking them
  - Change the aesthetics of a performance space
  - Soften the tone of sound energy reflecting from them
  - Change the reverberation time of the sound**

*Answer is D: The reflective material bounces the sound, increasing reverberation time for music, while the absorptive side deadens it to make speech more comprehensible)*

12. Duct silencers are usually \_\_\_\_\_ .
- Perforated metal baffles that absorb noise**
  - Intermediate sections of flexible duct material
  - Reflective sheets that redirect motor noise inward
  - Flexible mounts below HVAC machinery

*Answer is A: They trap the kinetic energy of the sound and let it dissipate while bouncing around inside the baffles*

13. Sound will enter from the lobby area, along with patrons leaving and returning to their seats. The best way to help with this is \_\_\_\_\_ .
- Discouraging patron movement during performances
  - An airlock or vestibule between the lobby and each entry**
  - Hanging plastic strips to seal off each entry
  - A white noise generator in the lobby

*Answer is B: These create buffer spaces where the sound energy coming from the lobby can be trapped and dissipate*

14. Geometric ceilings, like domes, barrels, or vaulted ceiling areas, will result in \_\_\_\_\_ .
- Focused noise**
  - Increased reverberation times
  - Lost clarity as sound energy dissipates
  - None of the above

*Answer is A: In other interesting news, there is a space on the rotunda floor of the U.S Capitol, where the domed ceiling collects the conversations of opposing party members and can direct their plans to an astute listener in the right position below it*

15. It is virtually impossible to completely block sound transfer between residential units due to \_\_\_\_\_ .
- Inability to enforce noise abatement rules
  - Higher frequency of children's voices
  - Sound transfer via impact noise
  - Prohibitive expense**

*Answer is D: The cost to do so simply cannot be recaptured in reasonable rent structures)*

16. The best way to isolate auditoriums from adjacent classrooms and lobbies is to \_\_\_\_\_ .
- Use adjacent spaces for classes producing the least noise
  - Use staggered stud construction in separating walls
  - Build corridors between them and other uses**
  - Install white noise generators facing outward into adjacent spaces

*Answer is C: This is obviously best done during planning and it creates spaces where noise from spaces which generate it can dissipate before entering an auditorium*

# PDH Academy

## AIA CES Course Evaluation

Thank you for completing this evaluation. We want to ensure that our training sessions are as meaningful as possible and appreciate your feedback. Please mail your completed forms to:

**PDH Academy, PO Box 449, Pewaukee, WI 53072**

If you would like to offer feedback on this course to AIA CES, please visit [www.aia.org/CESFeedback](http://www.aia.org/CESFeedback)

<b>Sound Advice</b>	<b>Course Number: AIAPDH182</b>				
<i>Using a scale from 1 to 5 where 1 is "Poor" and 5 is "Excellent," please evaluate the course in the following areas: (circle one number per question)</i>					
	Poor				Excellent
1. Overall satisfaction with this course	1	2	3	4	5
2. Course learning objectives clearly stated and met:	1	2	3	4	5
3. Satisfaction with the format of this course:	1	2	3	4	5
4. Met overall personal objectives for attending:	1	2	3	4	5
5. Quality of course content:	1	2	3	4	5
6. Applicability/value of new knowledge, ideas or information:	1	2	3	4	5

How could these courses be improved?

---

---

---

What other topics would be of interest?

---

---

---

Additional Comments:

---

---